

## Agenda with anticipated speakers:

1. nTMM installation progress report - ~~Arina~~, Yuri ~ 10'
2. Discussion of environmental field non-uniformity and the effort of remediation - Yuri, John ~ 20'
3. COMSOL simulation of the field in magnets - Mubi, Chris ~ 20"
4. AOB

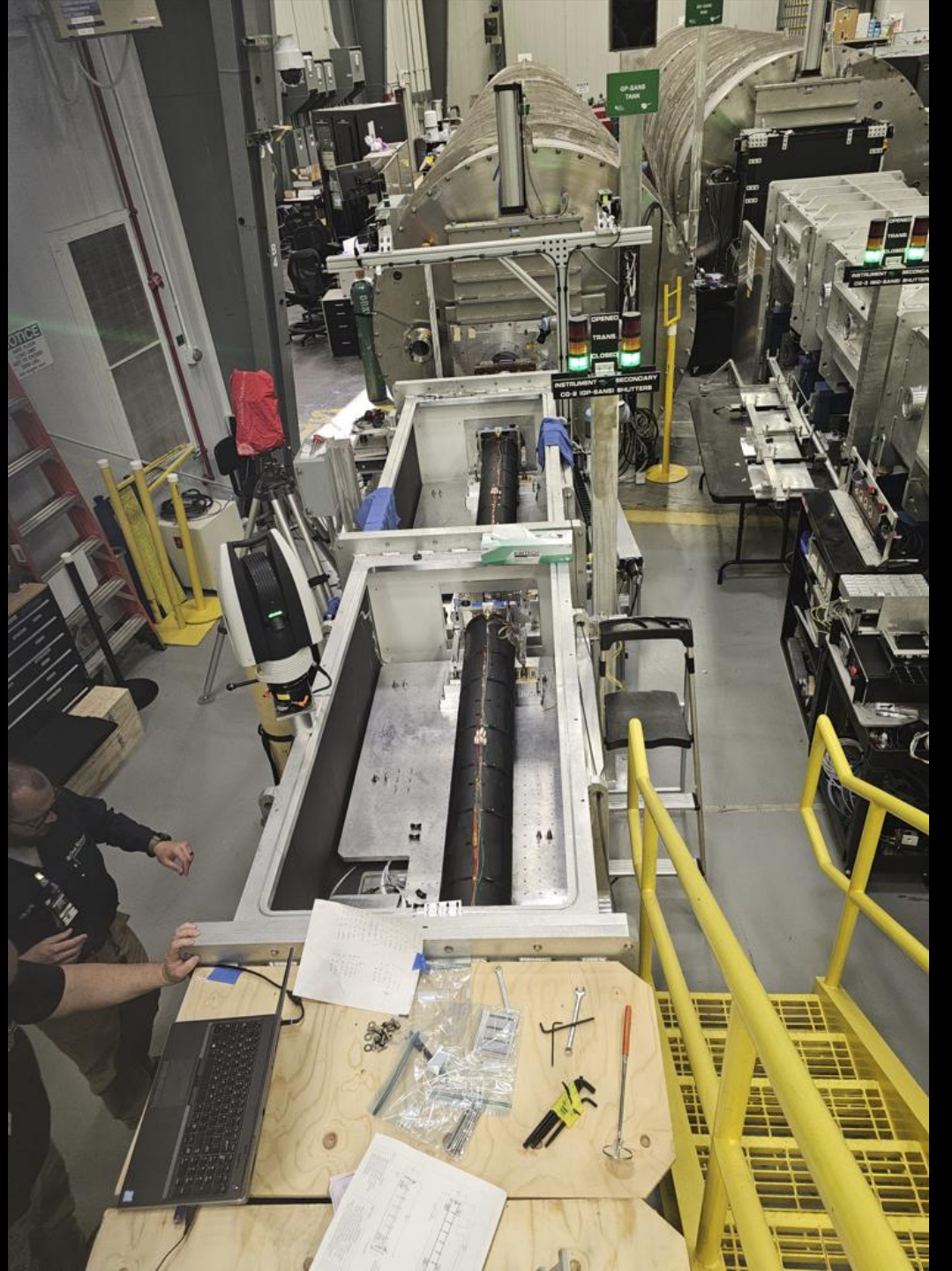

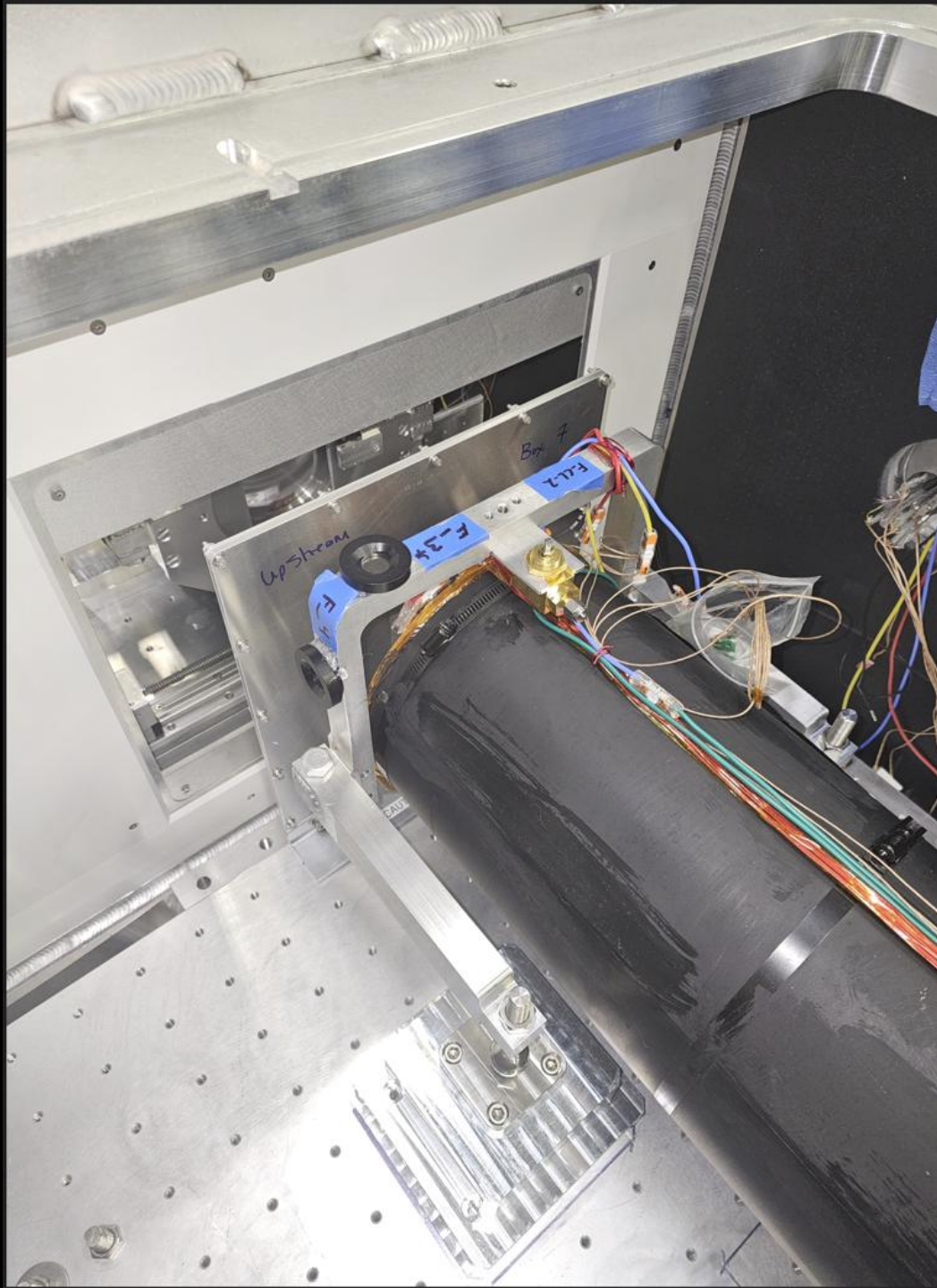

# Thermocouple's location on Magnet 2 (in box 8)

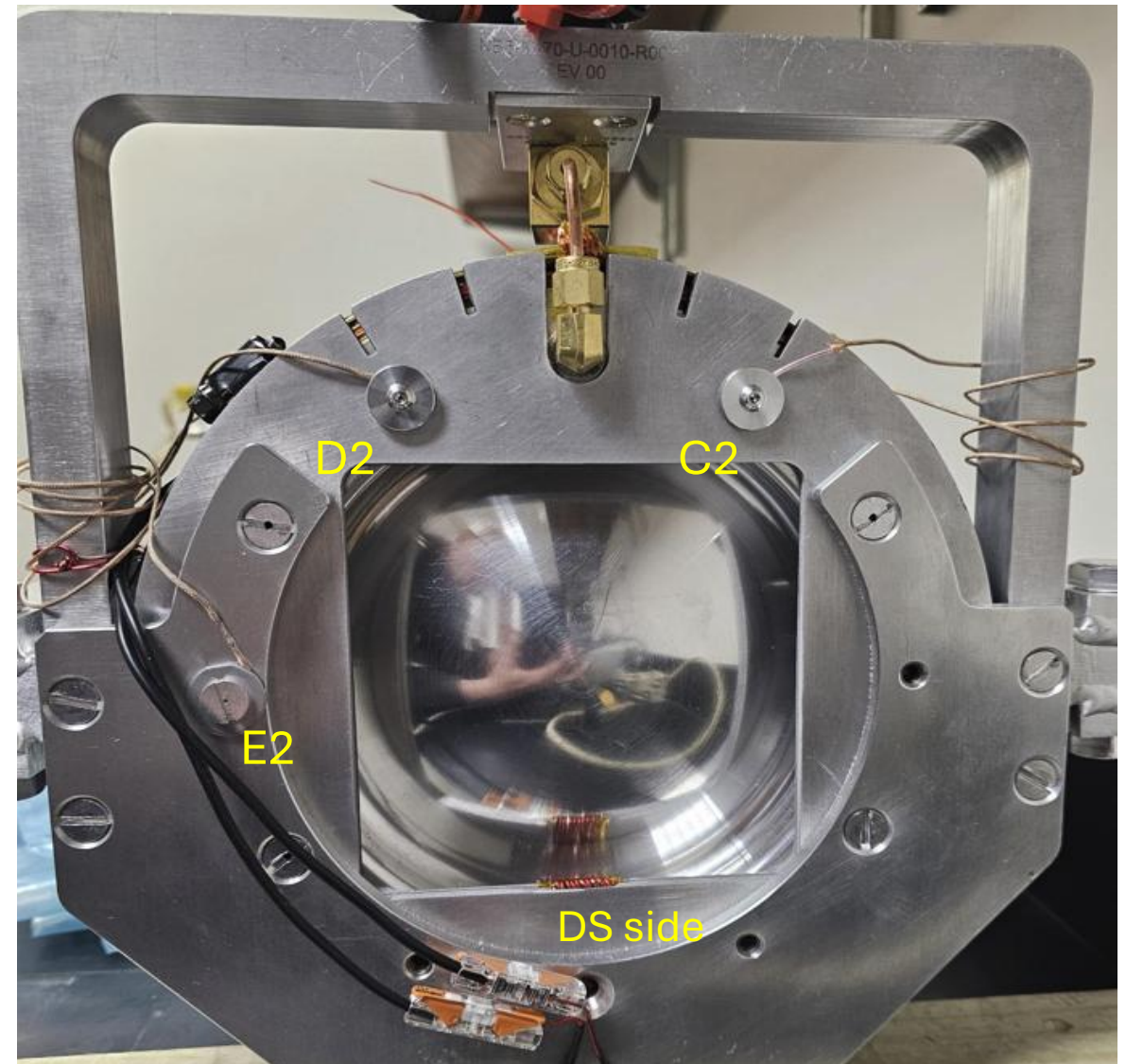
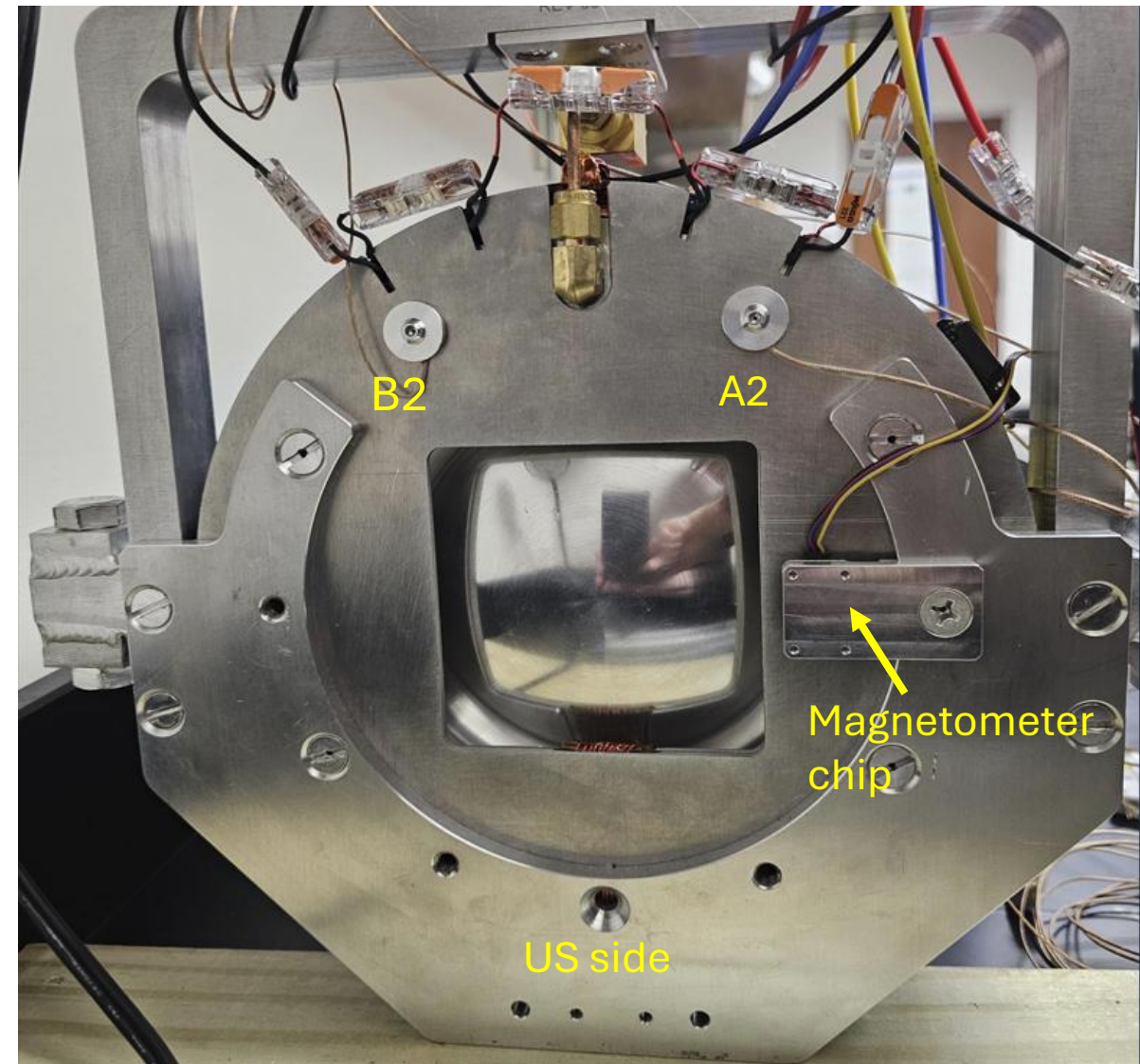

# Thermocouple's location on Magnet 1 (in box 7)

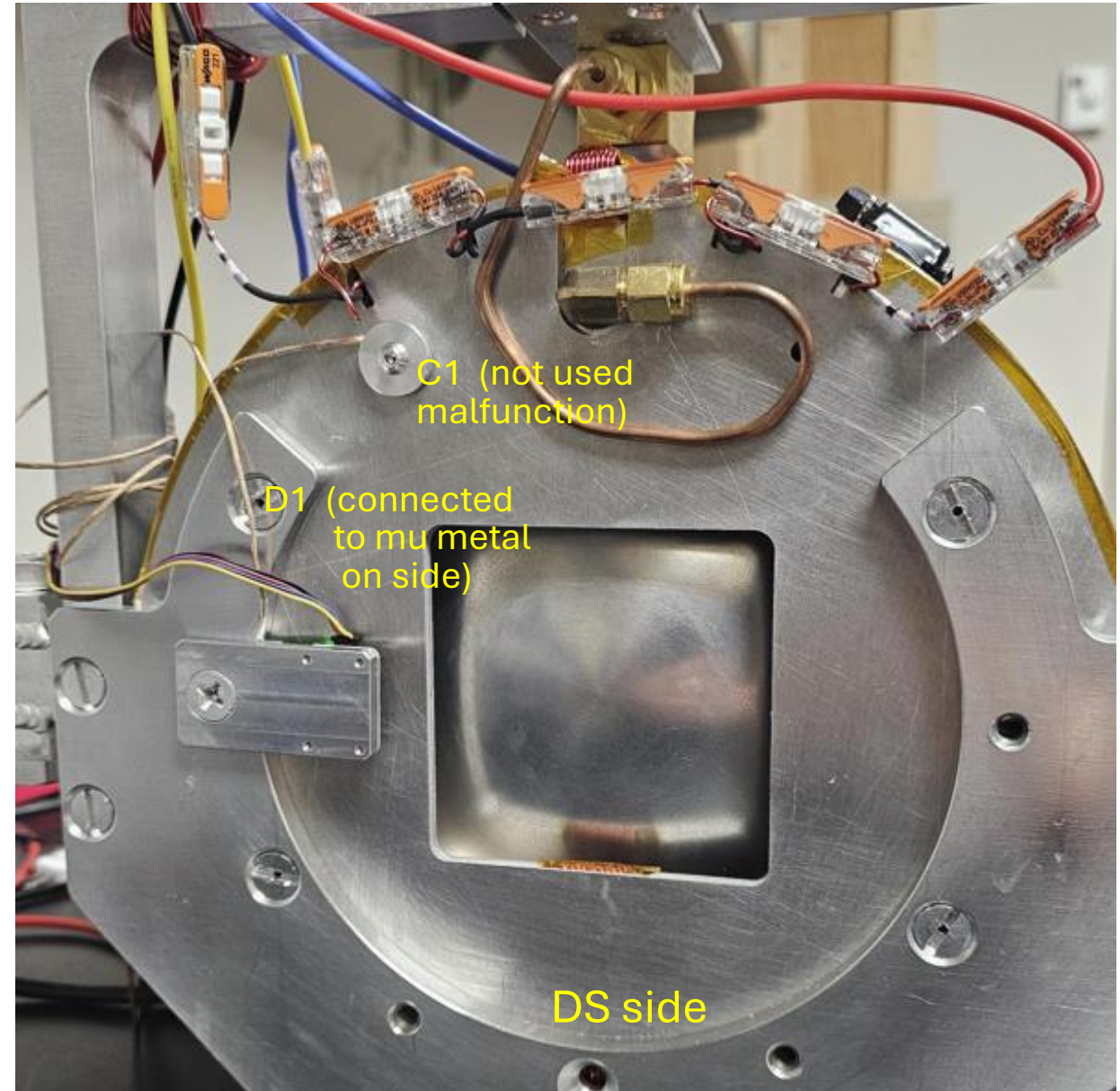
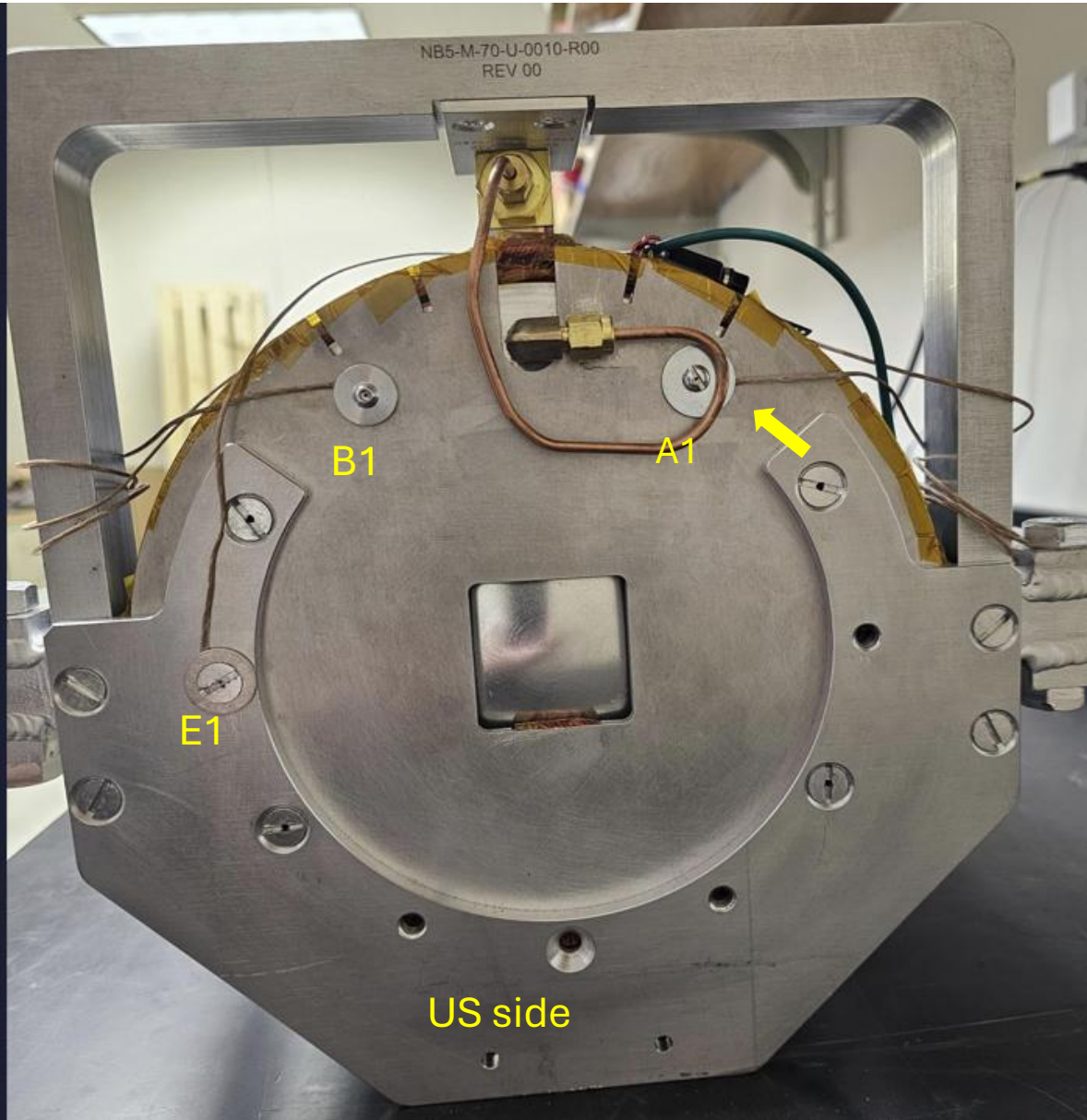

# Connections and software

1. Two TDK-Lambda power supplies are connected and being debugged.  
Current in CC mode, 0.3200 A - 0.3500 A, step 0.0004 → 75 runs of 30'
2. 8 thermocouple channels will be included in GP-SANS readout (1 Hz)
3. 2 new chip magnetometers will be included in GP-SANS readout



All systems were tested and functioning

Degaussing system was tested OK – will be used occasionally

4. Hope that Matt will help with creating run .txt format extraction
5. James promised to write a code for express analysis

# Next schedule

Agreed with Lisa that guide boxes closing will be **June 19** latest and pumping will start during her vacation

Dry system run without neutrons can be after **July 4**

Expected beam time earliest **July 22**, more likely **July 29** or later

# Magnetic Field measurement around the magnet with Android S23 U Phone

## Magnet 1 Box 7

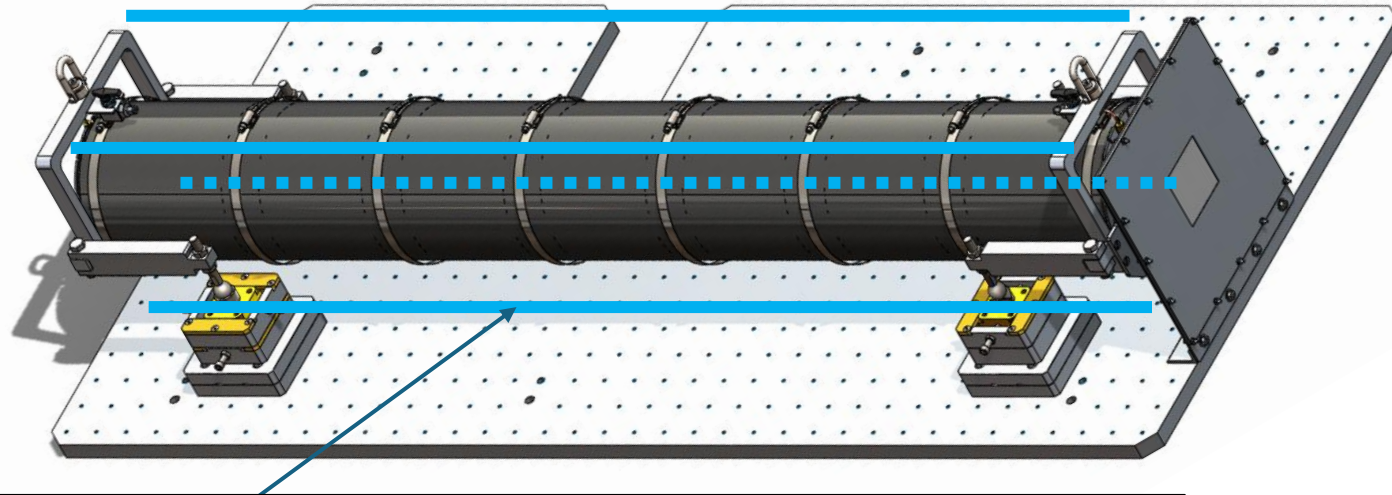

$B_{tot}, \mu T$

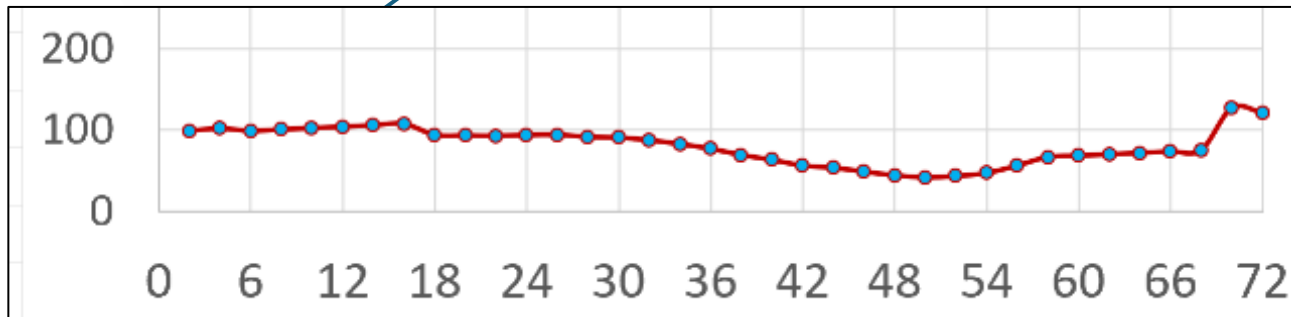

*inches*

3-D point every  
2" along the beam

# Magnet 1(7)

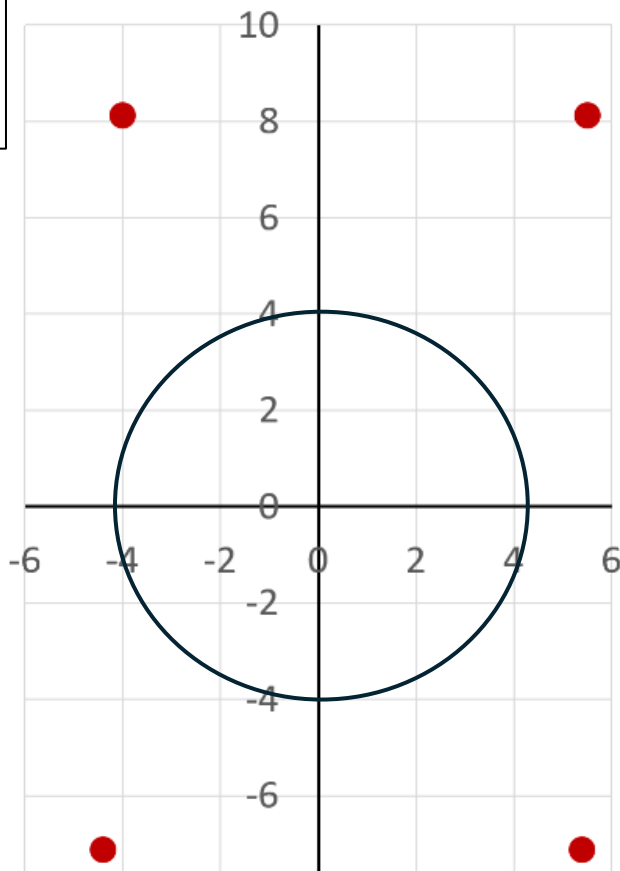
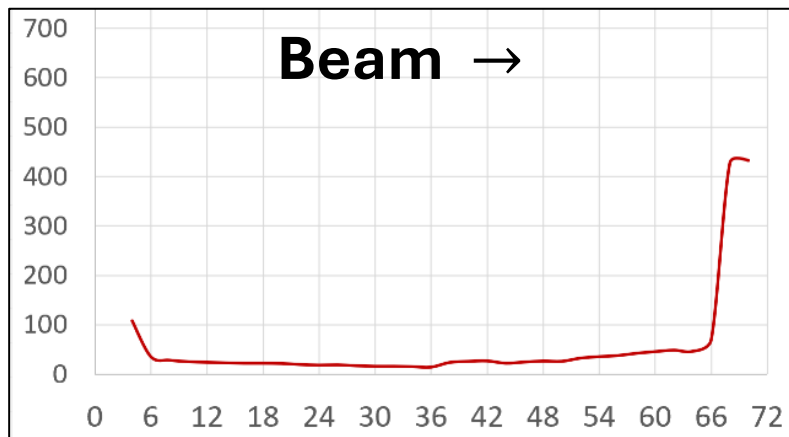
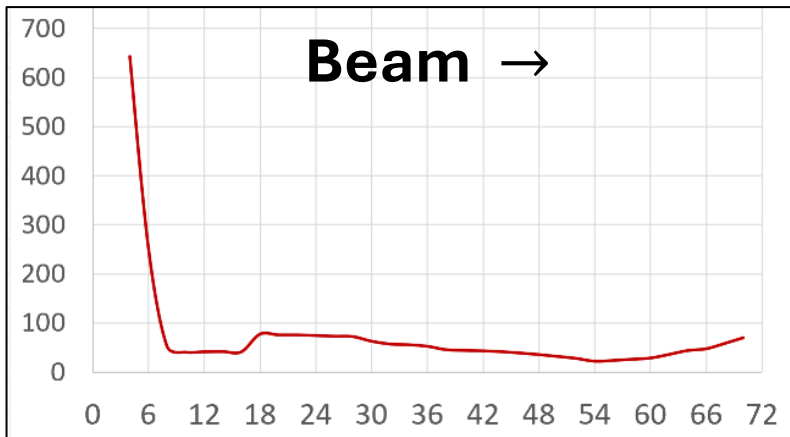

← *Ladder side*

*Wall side* →

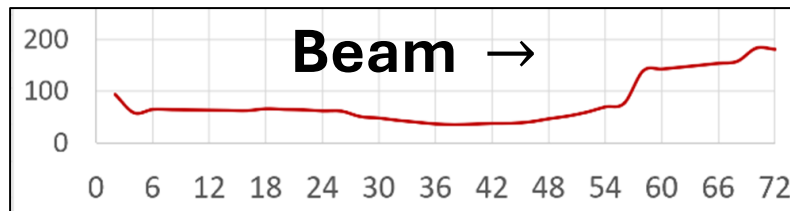
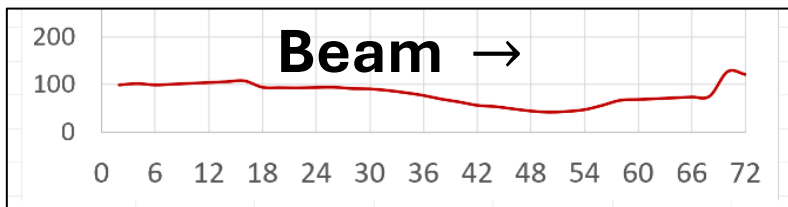

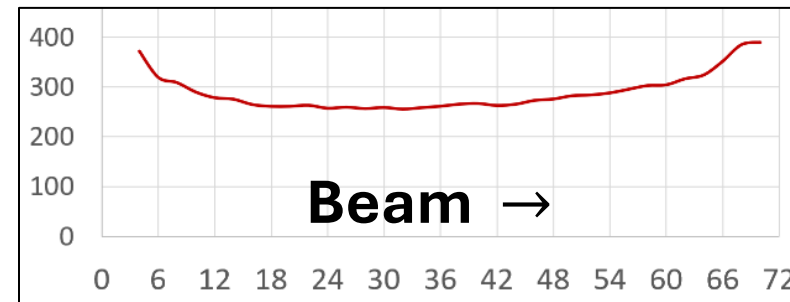
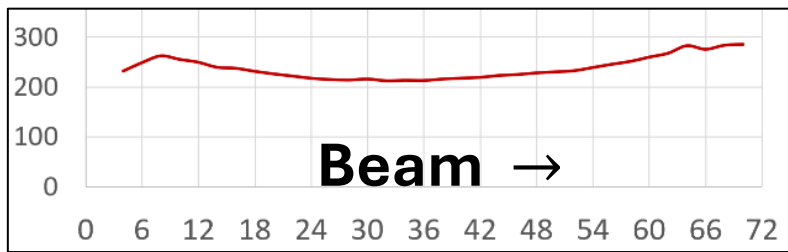

# Magnet 2(8)

← *Ladder side*

*Wall side* →

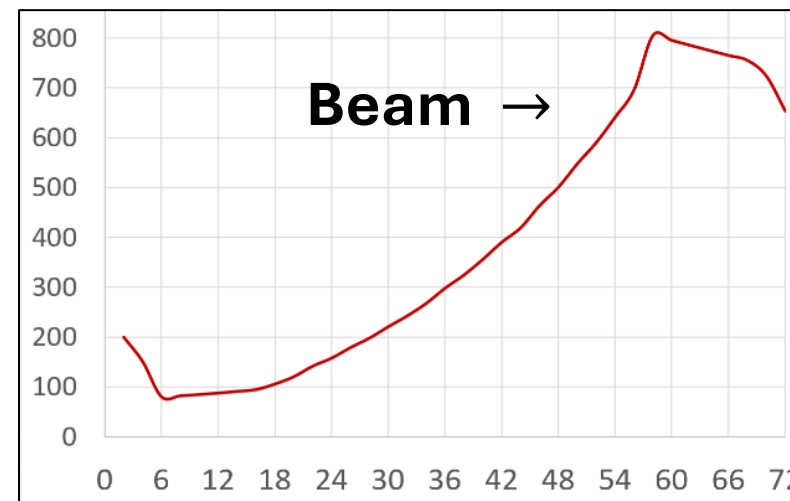
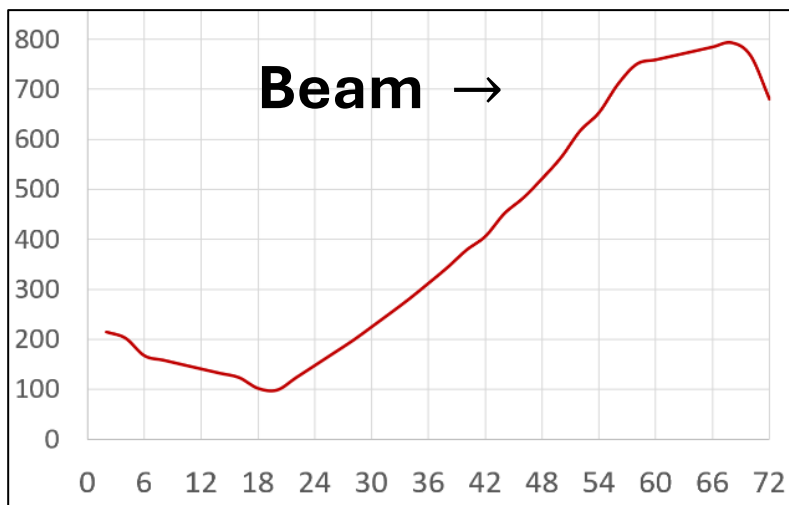
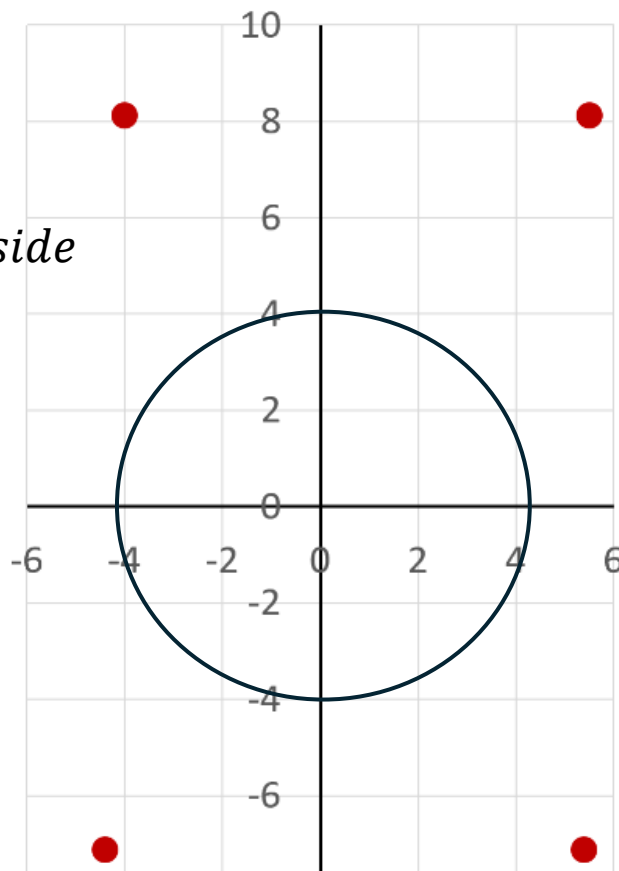

### Magnet 2(8) , Down

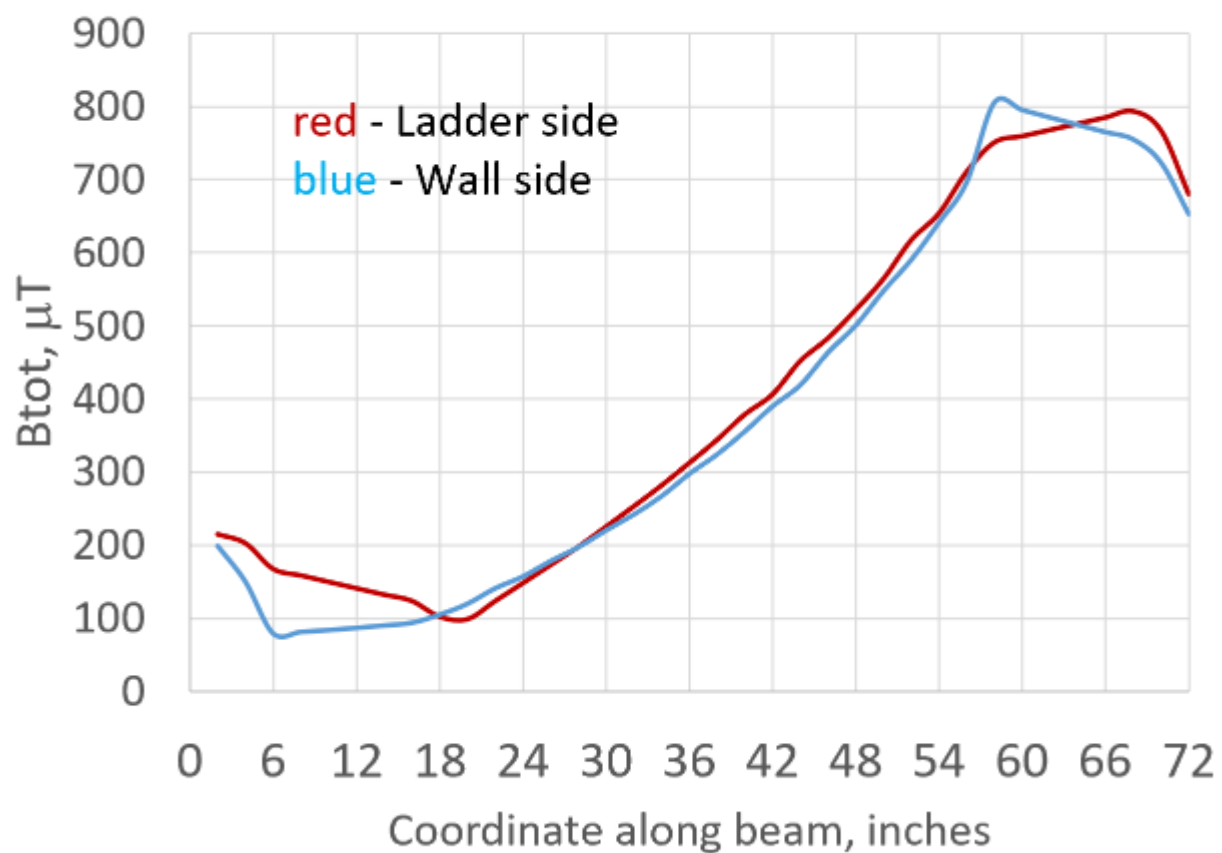

### Magnet 2(8) , Top

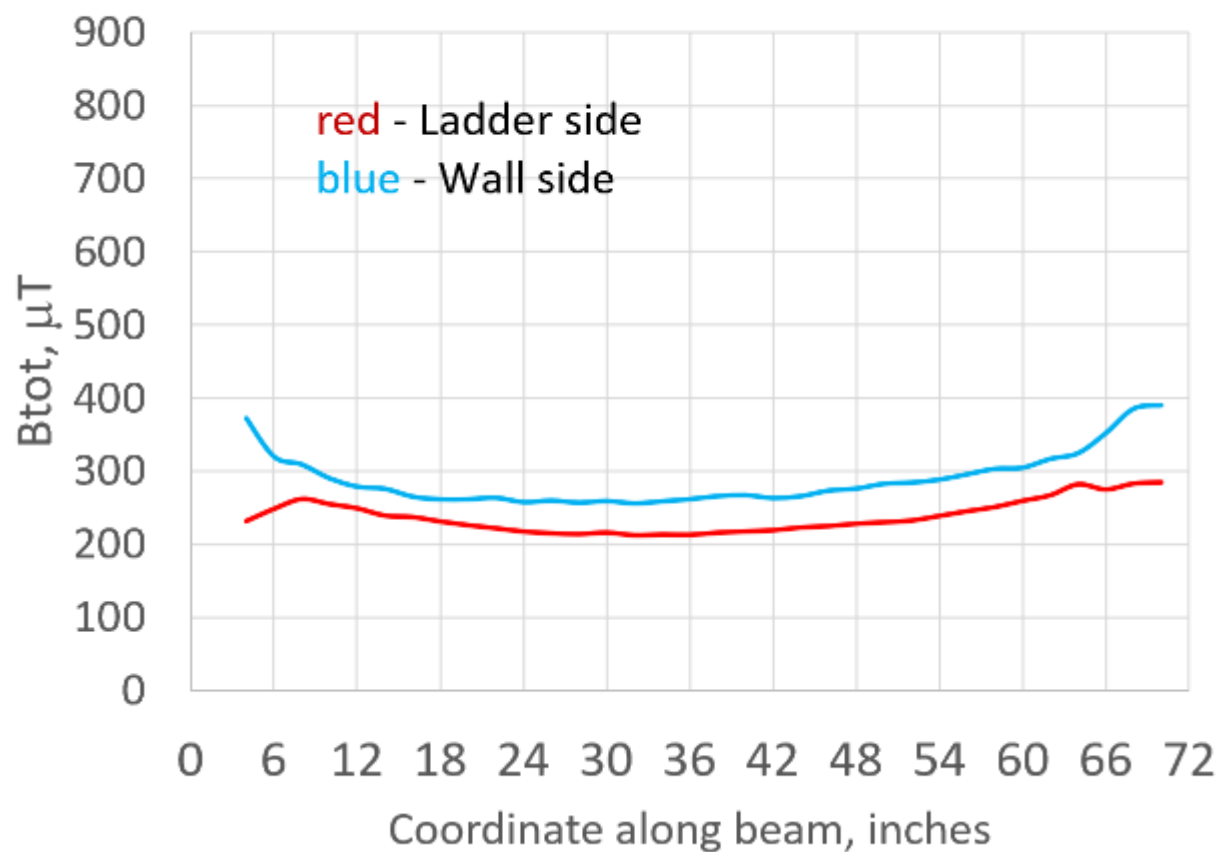

- Hot spot upper level
- Hot spot lower level

Guide Section 7

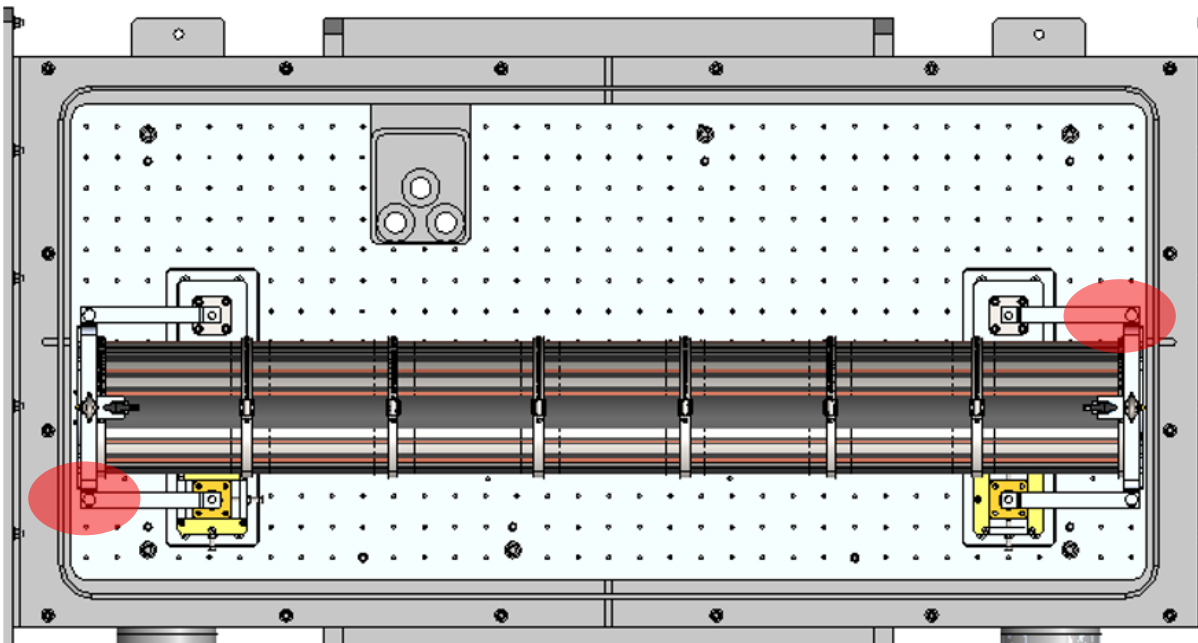

Guide Section 8

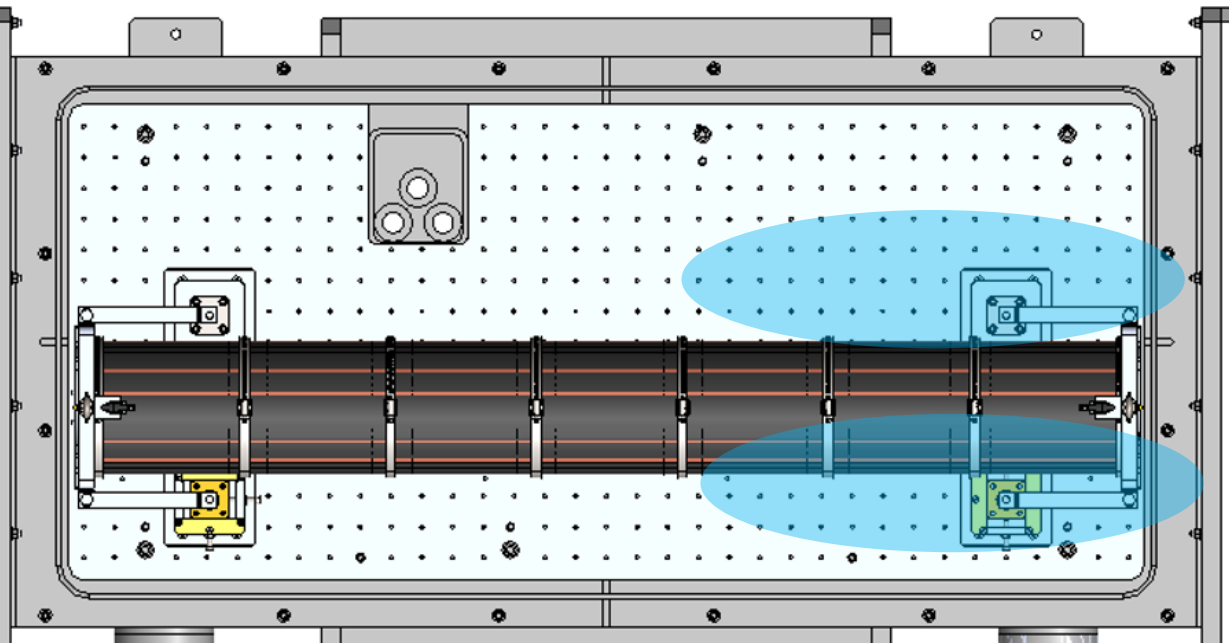

FWHM of expected resonance ( $V_F - \mu B = 0$ ) is  $\sim 0.15$  Gauss  
Step in field scan FWHM/5  $\sim 0.03$  Gauss  
Scan region 25 – 27 Gauss, resonance peak expectation at 26 Gauss  
In current: from 0.32 A to 0.35 A with step 0.0004 A

Mag. field non-uniformity requirement  $< 0.03$  Gauss  
Required suppression factor 8 Gauss / 0.03 Gauss  $> 270$   
Expected field non-uniformity  $< 0.1$  Gauss and expected suppression  $> 36$

For cylinder of mu-metal with diameter  $D$  and thickness  $T$  and rel. permeability  $\mu (H)$   
theoretical transversal suppression factor  $S \approx \mu (H) \cdot T/D$   
longitudinal suppression factor  $\sim 10$  times worse

In the original design  $T = 0.6 \text{ mm}$ ,  $D = 8.5 \text{ to } 25.4 \text{ mm}$ ,  $\mu$  depends on the external field  
For non-uniformity 0.1 Gauss  $\mu > 50,000$   $S \sim 140$   
For non-uniformity 8 Gauss  $\mu > 1,000$  ??  $S \sim 2.8$

**We need additional layer of magnetic shielding !**

# D.C. PERMEABILITY

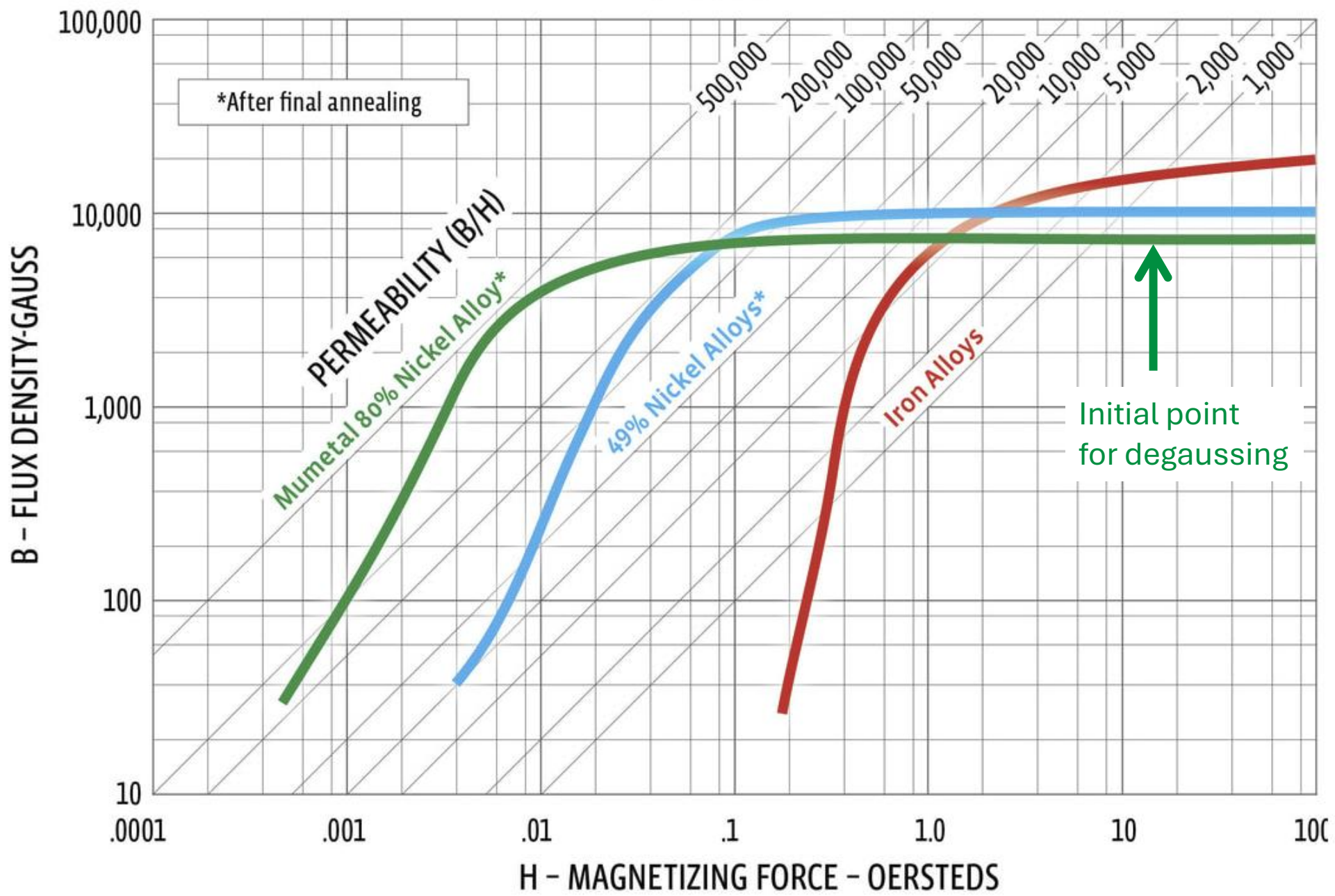

Space available for additional mu-metal shield on both magnets

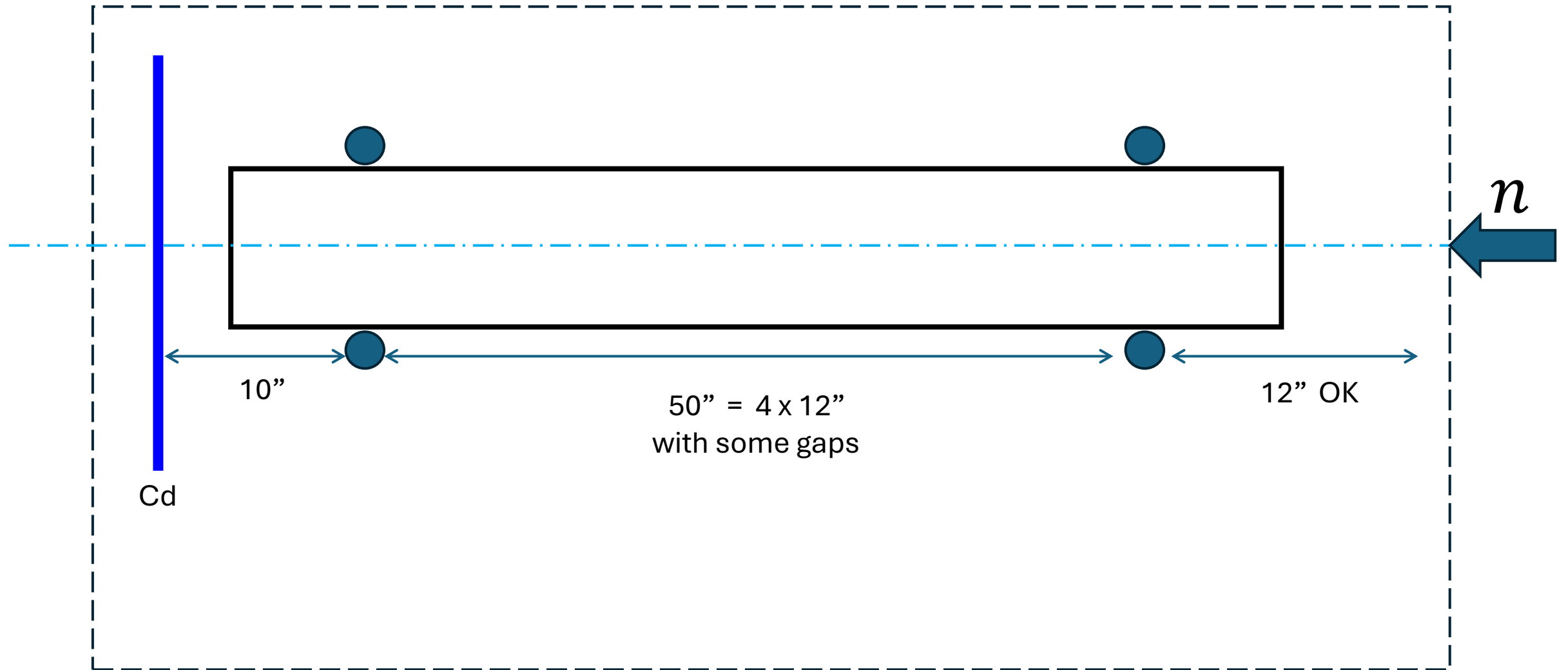

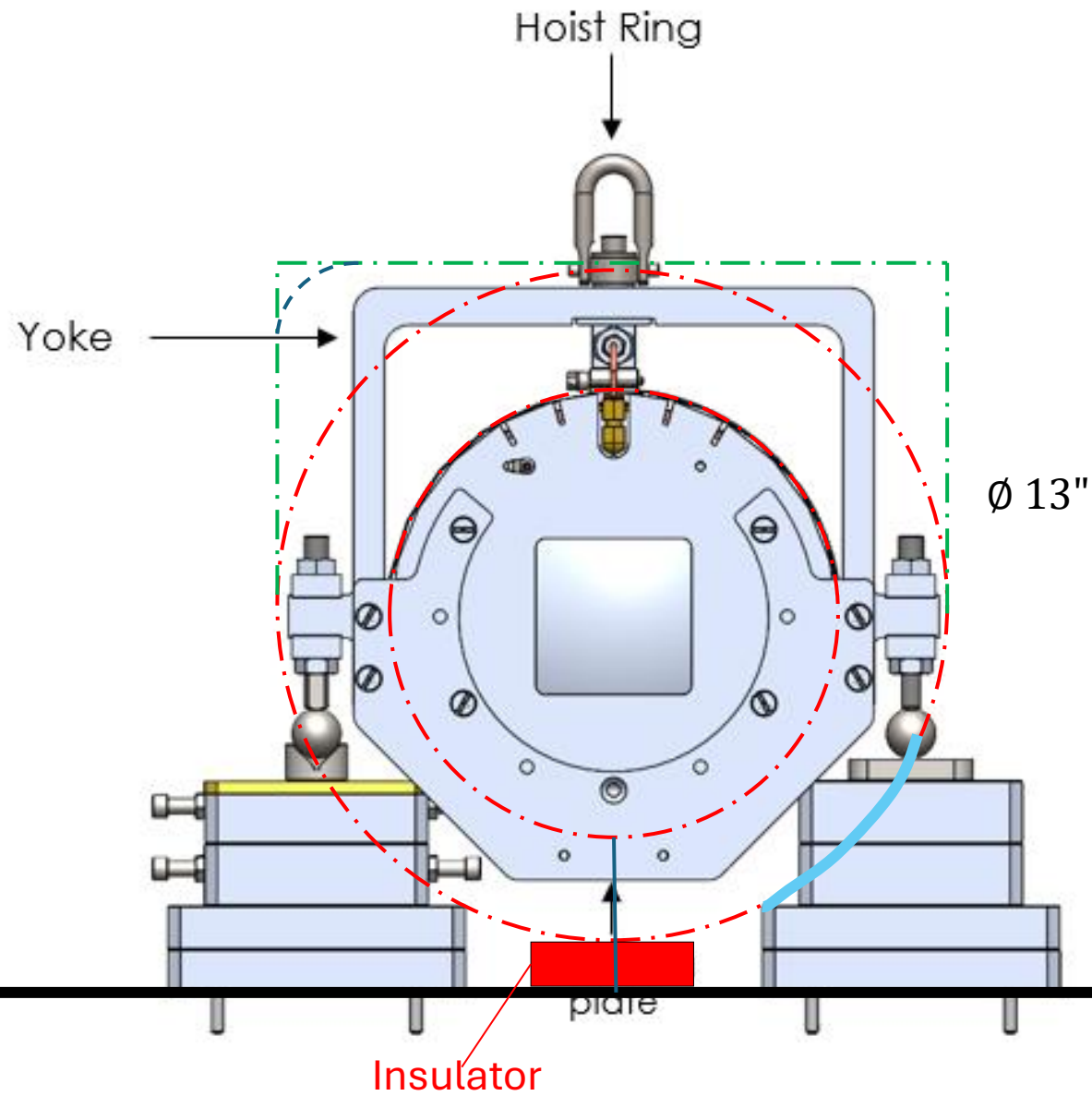

Ø 13"

