

# ALICE Inner Tracking System 2: Performance and Operational Experience

Jiyoung Kim<sup>1, 2</sup> on behalf of the ALICE Collaboration,

<sup>1</sup>Inha University, Korea, <sup>2</sup>CERN

The 33rd International Workshop on Vertex Detectors

25-29 August 2025



# A Large Ion Collider Experiment (ALICE)

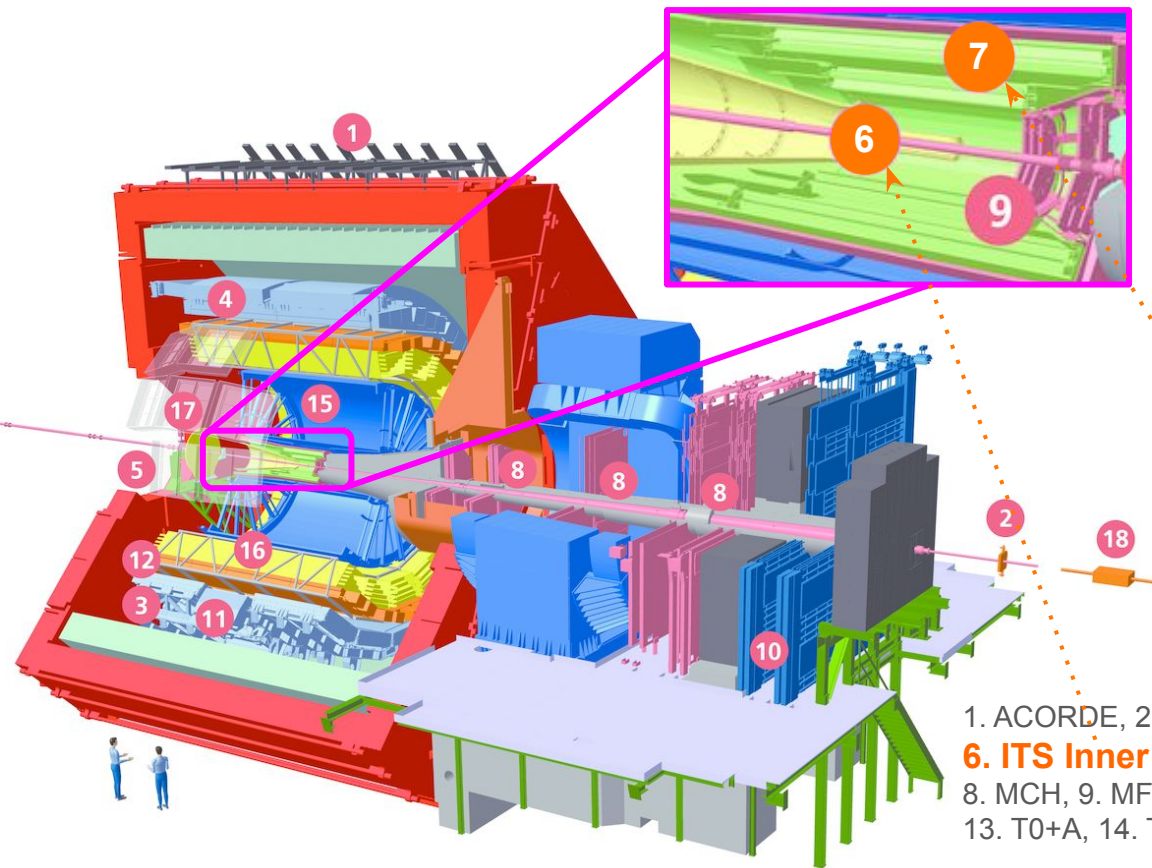

- Study of Quark-Gluon Plasma (QGP) created in heavy ion collisions at the LHC
- **High pointing resolution and low-mass detector** is crucial for accurate tracking and vertexing down to low  $p_T$  particles
- **Inner Tracking System 1 (ITS1)**, based on silicon-drift, strip, and pixel detectors, **has been replaced by the all-pixel ITS2 operating since 2021**
- ALICE beam pipe outer radius was reduced from 28 mm to 18 mm

[ALICE, JINST 19 \(2024\) P05062](#)

1. ACORDE, 2. AD, 3. DCal, 4. EMCal, 5. HMPID,  
**6. ITS Inner Barrel, 7. ITS Outer Barrel,**  
8. MCH, 9. MFT, 10. MID, 11. PHOS / CPV, 12. TOF,  
13. T0+A, 14. T0+C, 15. TPC, 16. TRD, 17. V0+, 18. ZDC

# ITS2 detector layout

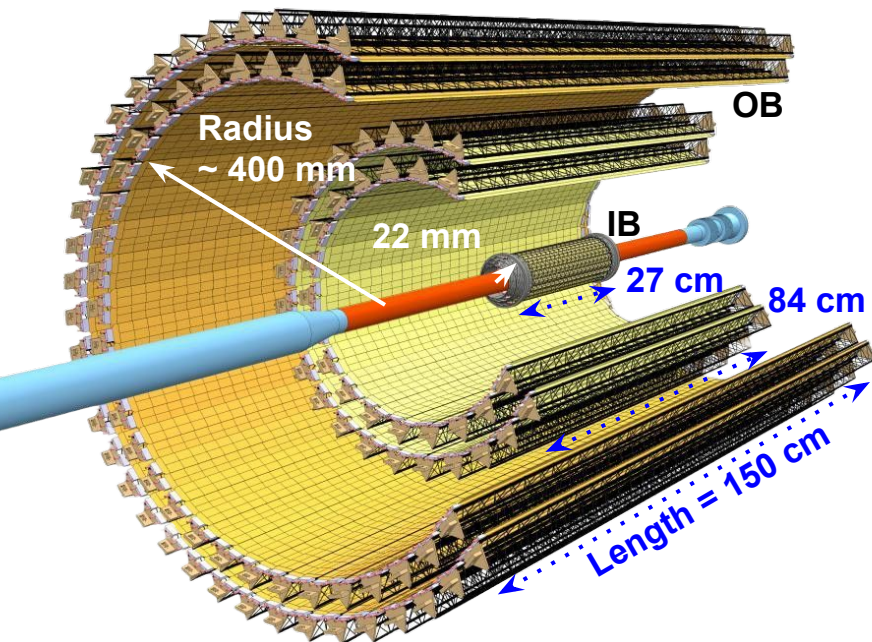

- ▶ Radius: from 22 mm to 400 mm
- ▶ Pseudorapidity coverage:  $|\eta| < 1.22$

- Inner Barrel (IB): 3 layers
  - ▶ **Sensor thickness: 50  $\mu\text{m}$**
  - ▶ Material budget:  $\sim 0.36\% X_0/\text{layer}$

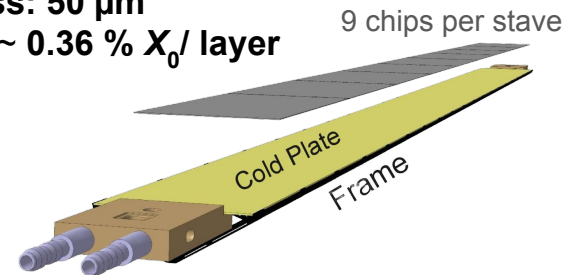

- Outer Barrel (IB): 4 layers
  - ▶ **Sensor thickness: 100  $\mu\text{m}$**
  - ▶ Material budget:  $\sim 1.1\% X_0/\text{layer}$

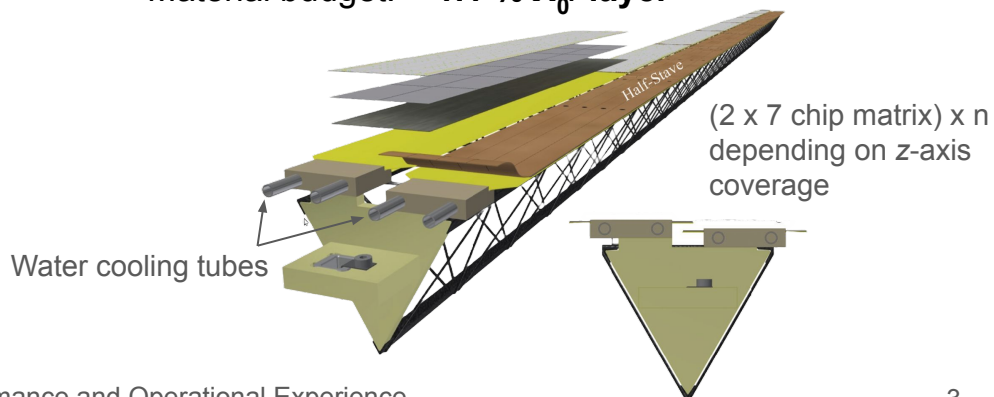

# ITS2 detector layout

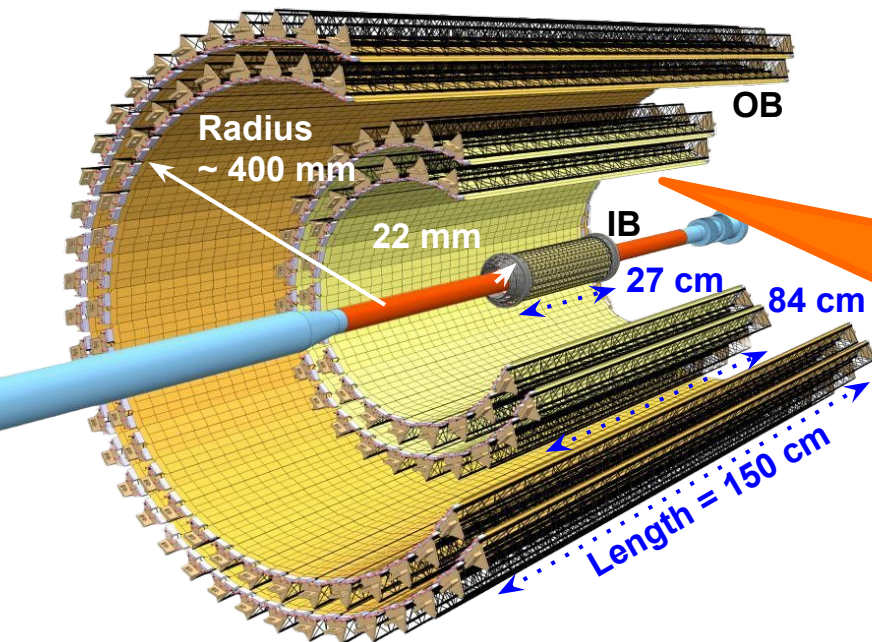

- ▶ Radius: from 22 mm to 400 mm
- ▶ Pseudorapidity coverage:  $|\eta| < 1.22$

- Inner Barrel (IB): 3 layers
  - ▶ **Sensor thickness: 50  $\mu\text{m}$**
  - ▶ Material budget:  $\sim 0.36\% X_0/\text{layer}$

9 chips per stave

10 m<sup>2</sup> active area  
24k chips

The largest Monolithic Active Pixel Sensor (MAPS)-based detector ever built in HEP experiments

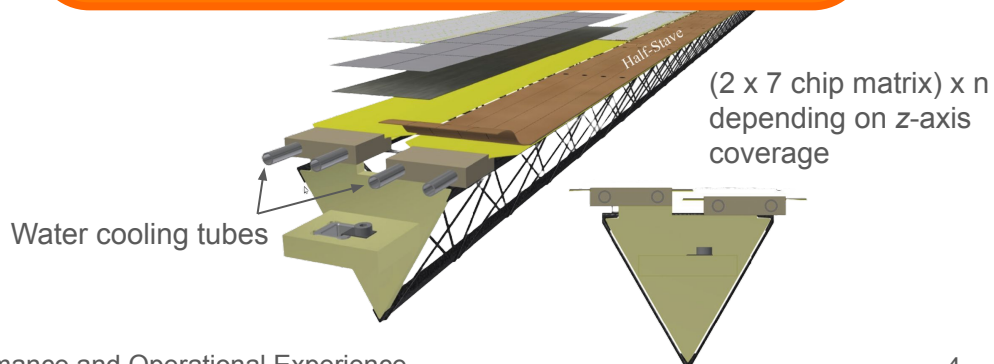

# ALICE Pixel Detector “ALPIDE” - the pixel chip for the ITS2

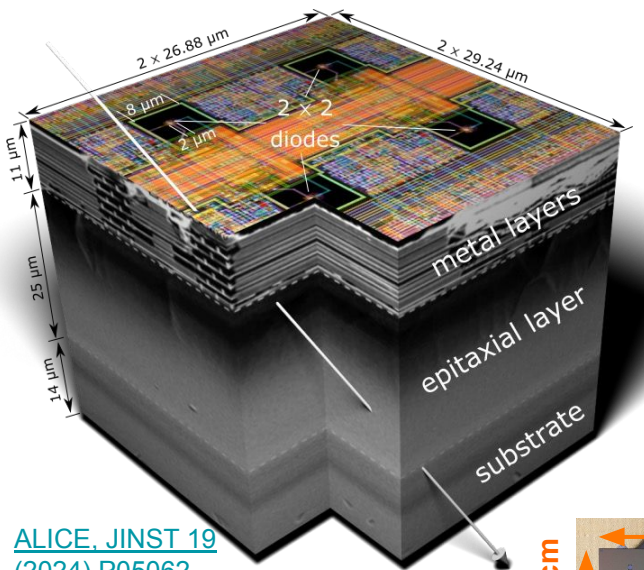

[ALICE, JINST 19 \(2024\) P05062](#)

- TowerJazz 180 nm full CMOS Imaging Sensor Process
- **Pixel pitch: 29 μm x 27 μm**
- **Spatial resolution ( $r_{\phi}$ , z): ~ 5 μm**
- Highly integrated circuit:  $O(100)$  transistors in-pixel:
  - ▶ Analog/digital signal processing, control and readout functionalities
- Low power consumption: **< 50 mW/cm<sup>2</sup>**
- Maintain **detection efficiency (> 99%)** and **fake-hit rate ( $\ll 10^{-6}$  /pixel/event)** beyond a Total Ionizing Dose (TID) of **270 kRad** and Non-ionizing Energy Loss (NIEL) of  **$2.7 \times 10^{12}$  1 MeV  $n_{eq}$ /cm<sup>2</sup>**
- On-chip bias generation e.g. to control charge threshold chip-wide

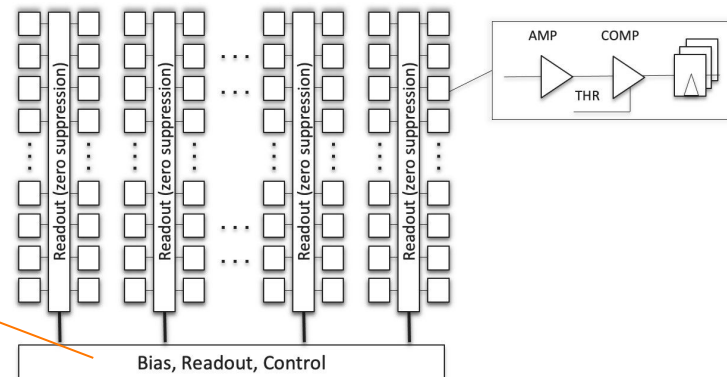
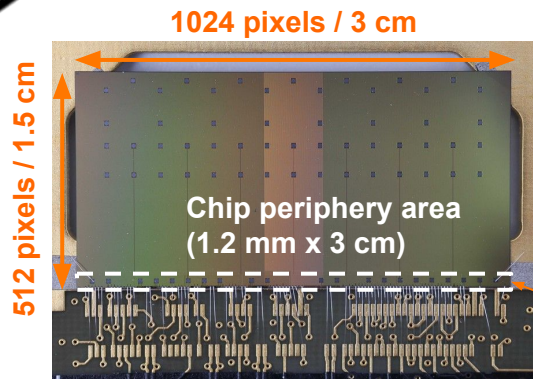

# Data readout architecture

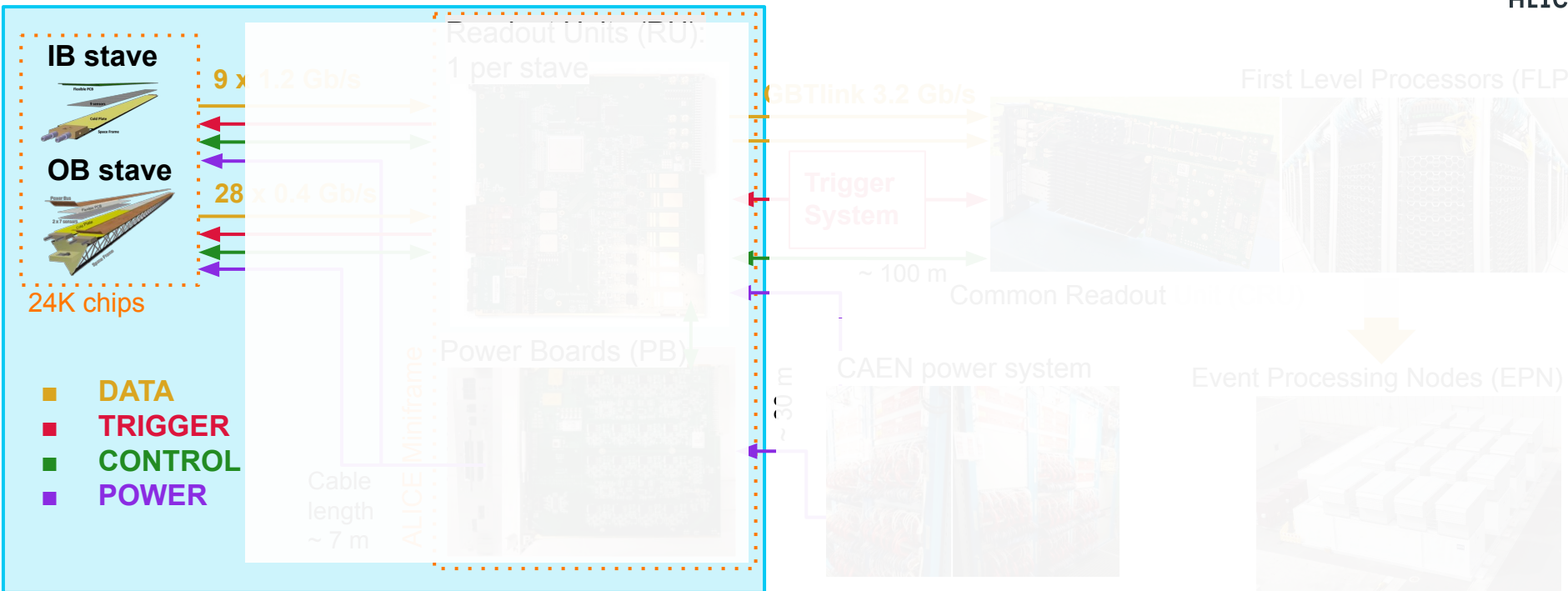

# Data readout architecture

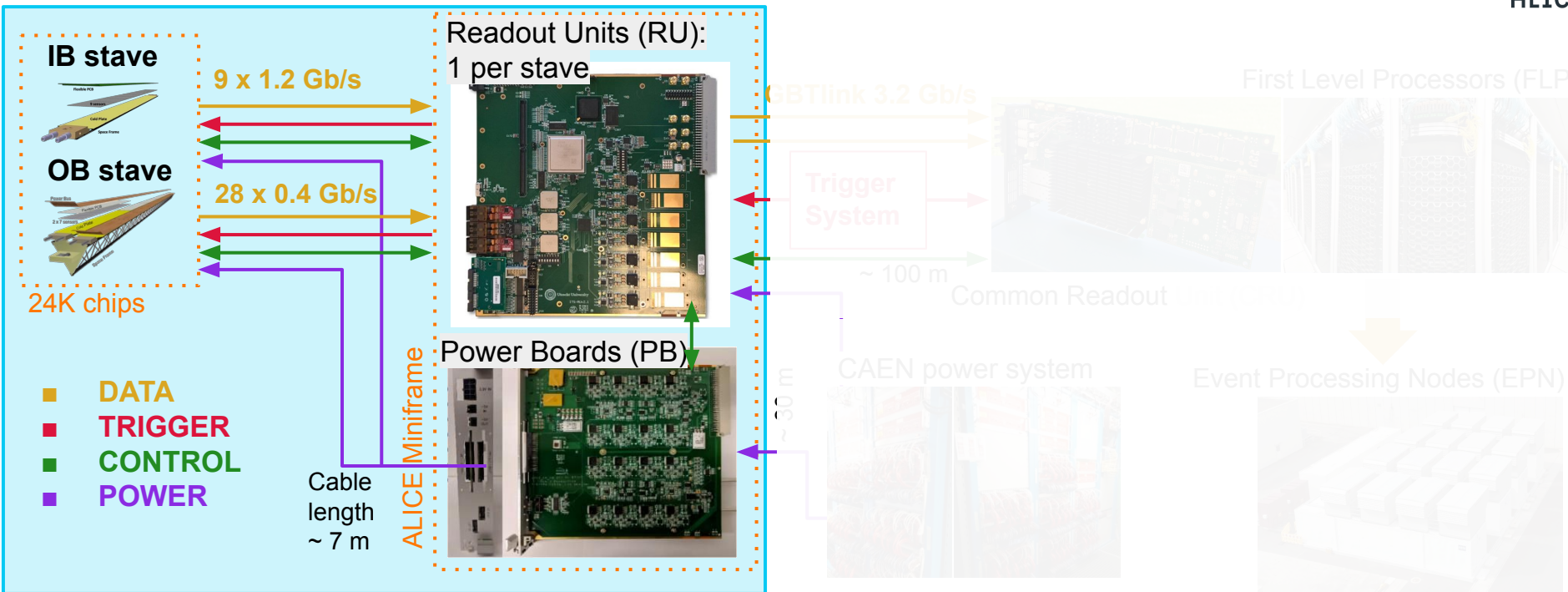

- Raw data from staves to RUs via copper link

# Data readout architecture

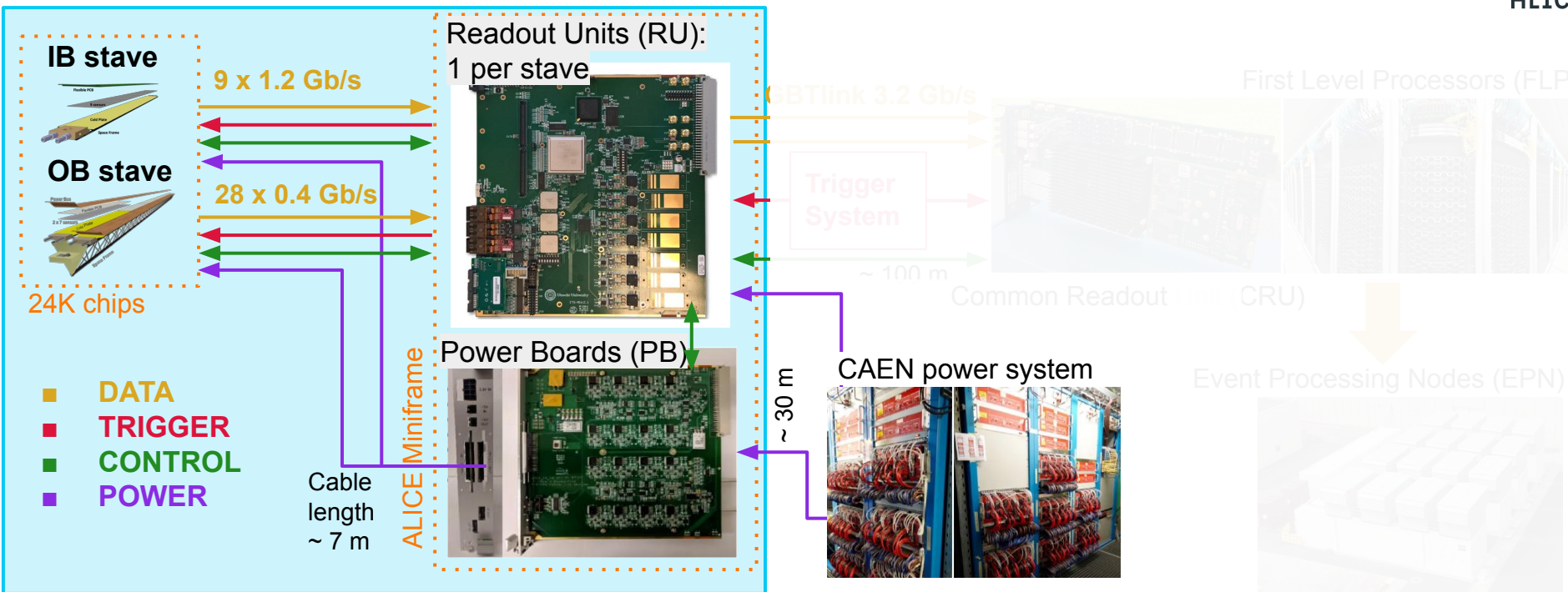

- Raw data from staves to RUs via copper link
- Optical GBT link between RUs and FLP/CRU (2-3 links per RU)

# Data readout architecture

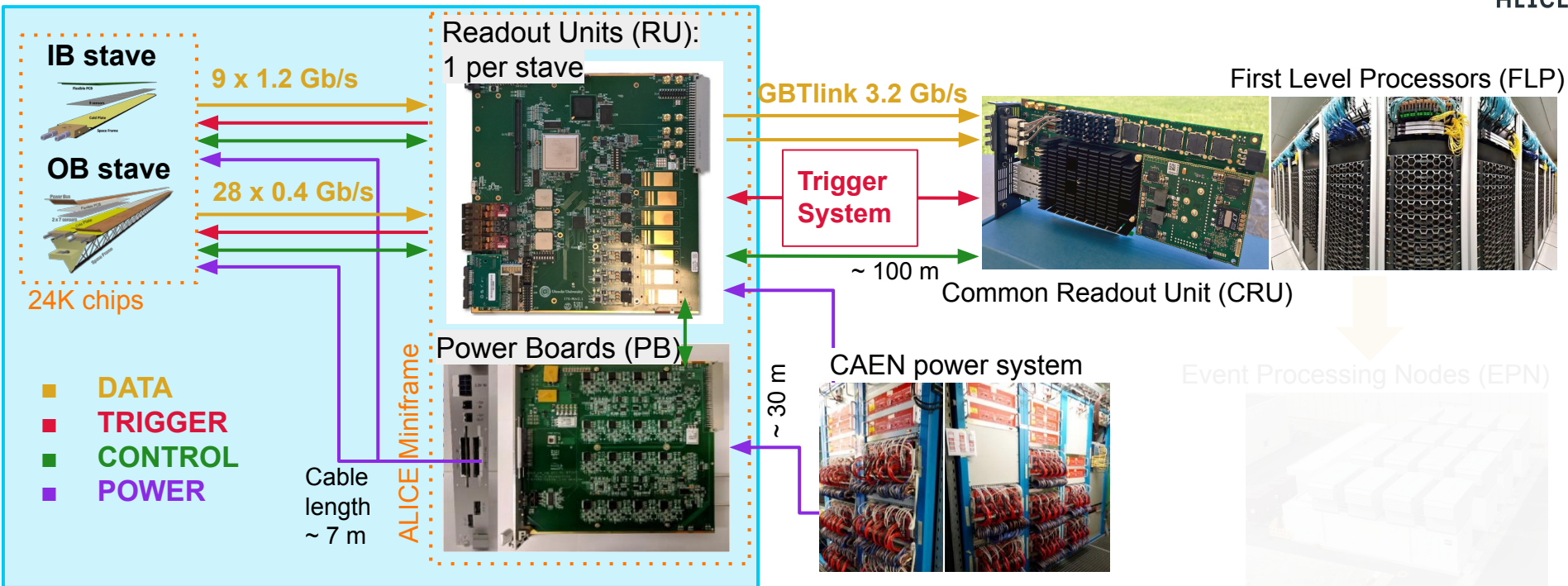

- Raw data from staves to RUs via copper link
- Optical GBT link between RUs and FLP/CRU (2-3 links per RU)

# Data readout architecture

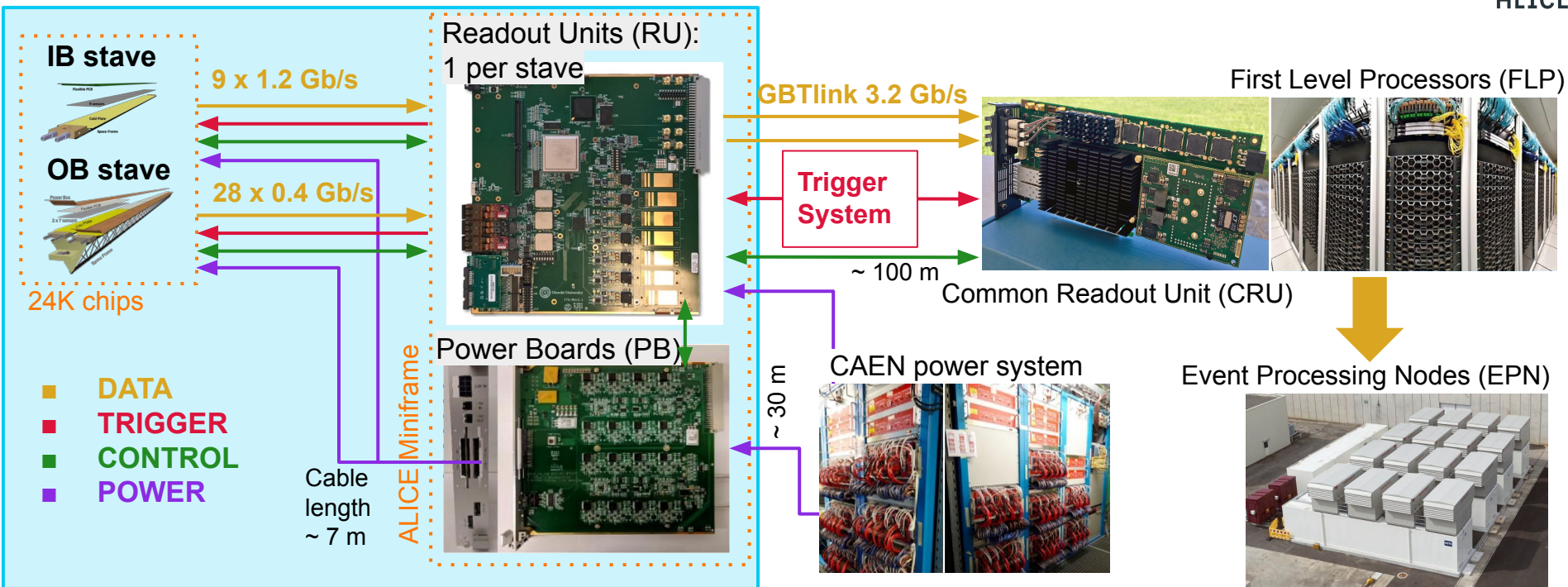

- Raw data from staves to RUs via copper link
- Optical GBT link between RUs and FLP/CRU (2-3 links per RU)

# Data readout architecture

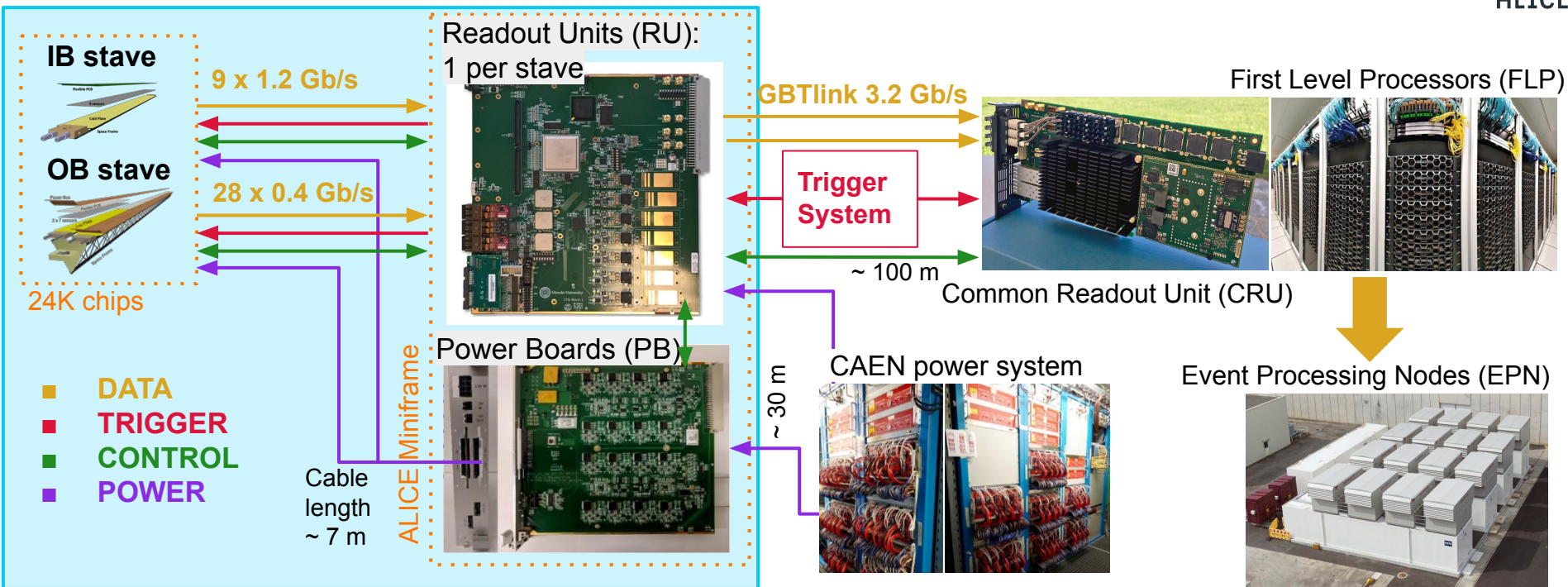

- Raw data from staves to RUs via copper link
- Optical GBT link between RUs and FLP/CRU (2-3 links per RU)
- Electronics (RUs, PBs) are located 7m-away from the interaction point: **radiation and magnetic field area**
  - ▶ FPGAs in radiation environment  $\Rightarrow$  scrubbing and triple modular redundancy to mitigate radiation effects

# Detector Control System and Online Quality Control

## ITS2 DCS UI Main view

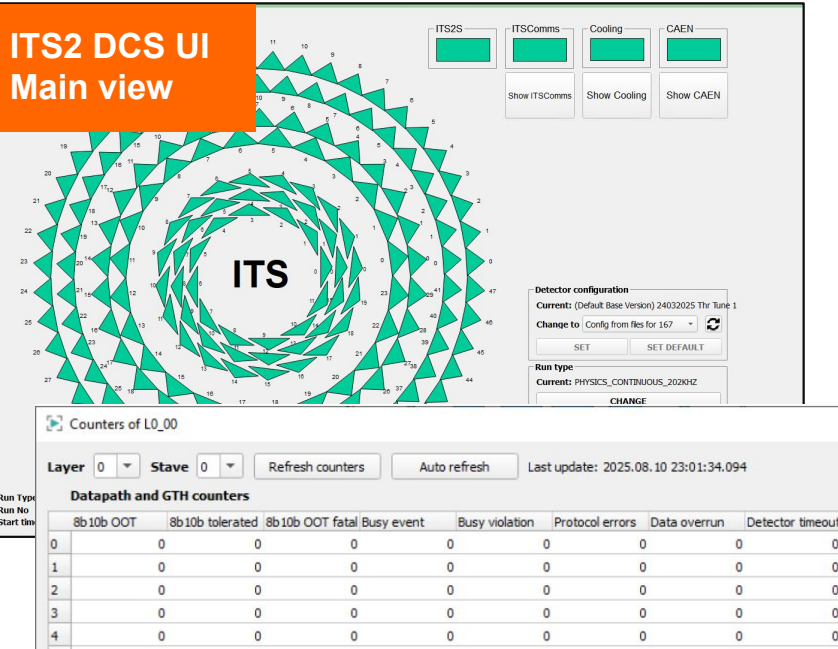

- Basic control and configuration of chips, electronics, and entire infrastructure
- Online RU process monitoring via counters
- Automatic error recovery during a run has been implemented to minimize data loss

- Several QC online workflows monitor data quality using sampled datasets from FLPs and EPNs
  - Diagnostics on raw data integrity and decoding errors
  - Hit and cluster occupancy monitoring
  - Reconstructed track observables analysis

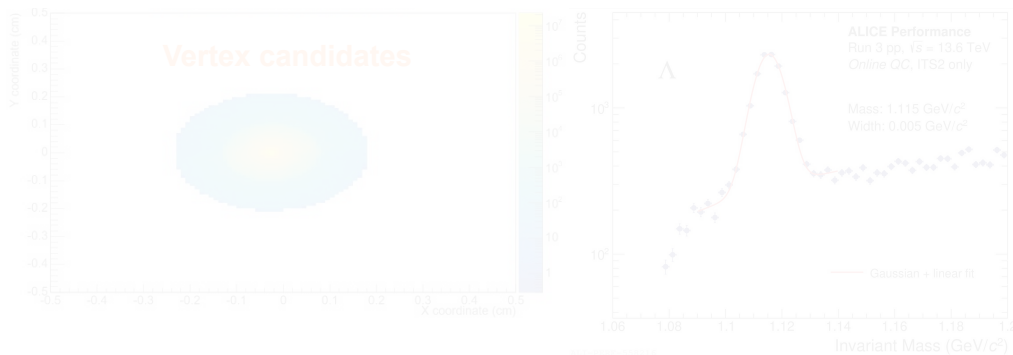
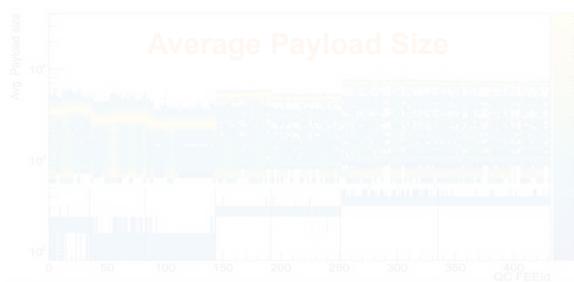

# Detector Control System and Online Quality Control

## ITS2 DCS UI Main view

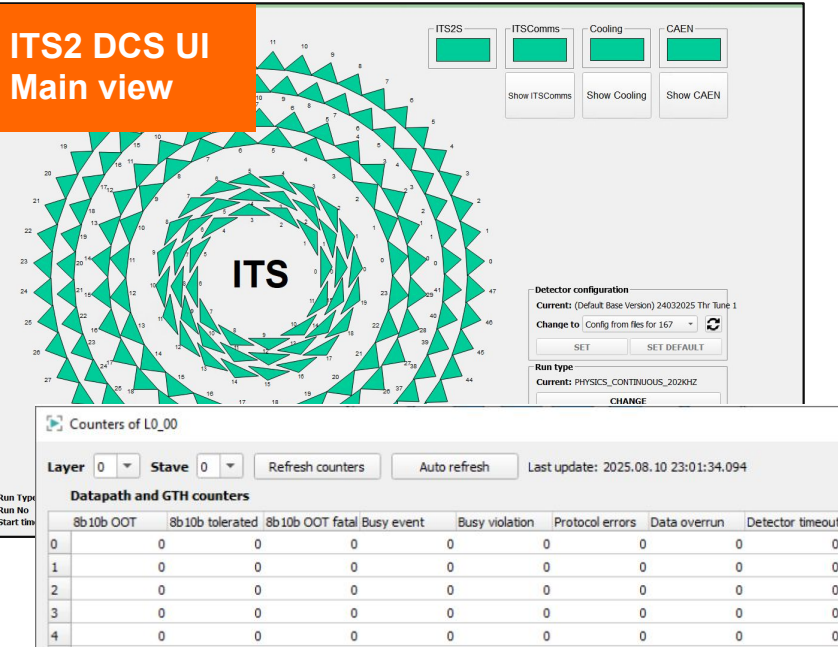

- Basic control and configuration of chips, electronics, and entire infrastructure
- Online RU process monitoring via counters
- Automatic error recovery during a run has been implemented to minimize data loss

- Several QC online workflows monitor data quality using sampled datasets from FLPs and EPNs
  - Diagnostics on raw data integrity and decoding errors
  - Hit and cluster occupancy monitoring
  - Reconstructed track observables analysis

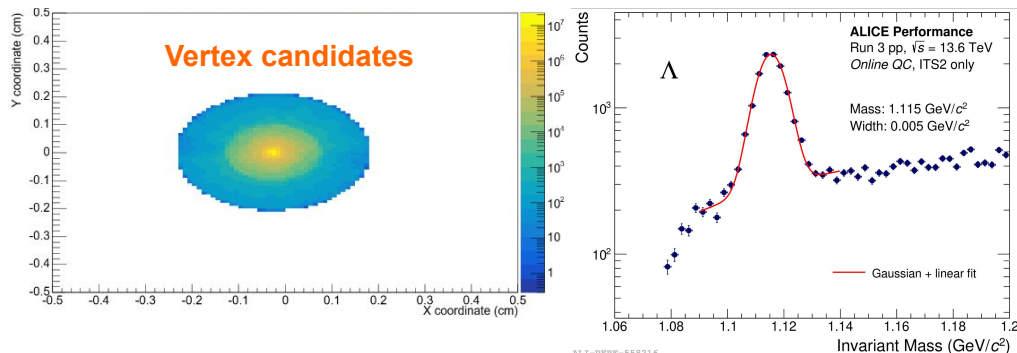
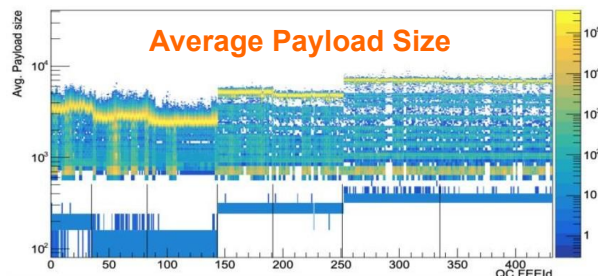

# ITS2 performance in Run 3

- Successful operation since 2021 in pp and Pb–Pb as well as pO/O–O/Ne–Ne special runs:

Collisions system	Interaction rate in ALICE	ITS continuous readout framing rate	Integrated luminosity (Stat. enhancement)
pp $\sqrt{s} = 13.6$ TeV	500 kHz	202 kHz	82 pb <sup>-1</sup> (3000 times)
Pb–Pb $\sqrt{s}_{NN} = 5.36$ TeV	Up to 50 kHz	67 kHz	3.3 nb <sup>-1</sup> (60 times)
O–O $\sqrt{s}_{NN} = 5.36$ TeV	Up to 45 kHz	67 kHz	5.01 nb <sup>-1</sup>

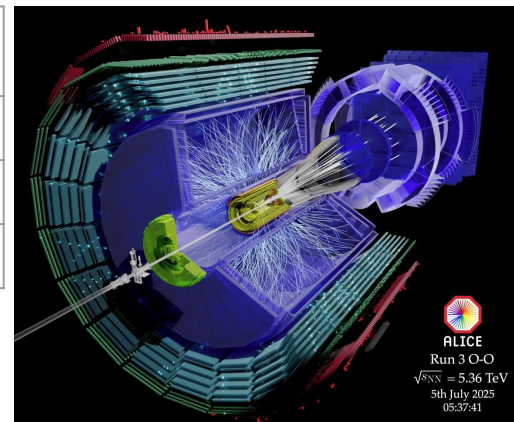

- 99.6 % active pixels in the entire detector
- In-run acceptance loss is at the level of percent, mostly automatically recovered
  - IB performs better than OB in terms of the dynamic acceptance loss

IB/OB dynamic acceptance loss per fill - pp in 2025

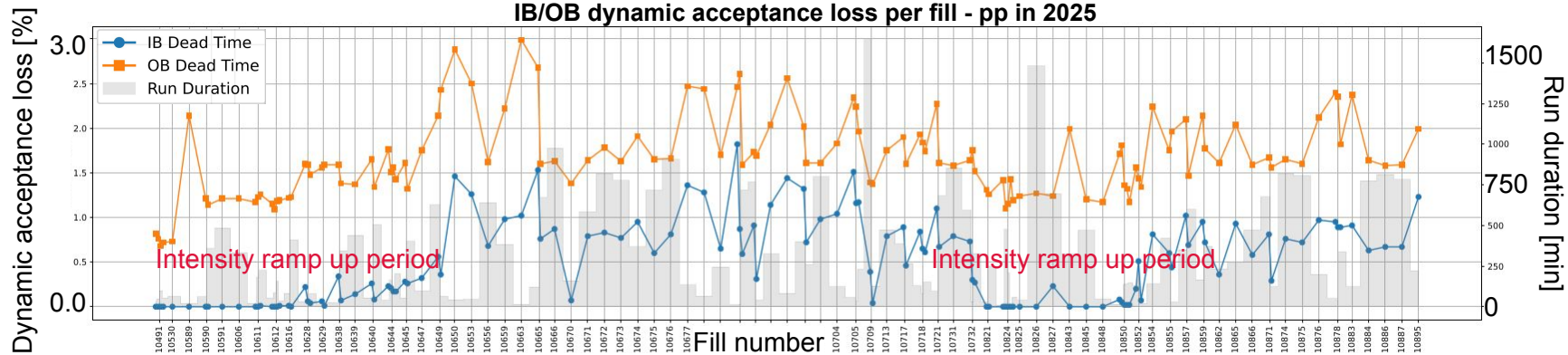

# Charge-threshold stability

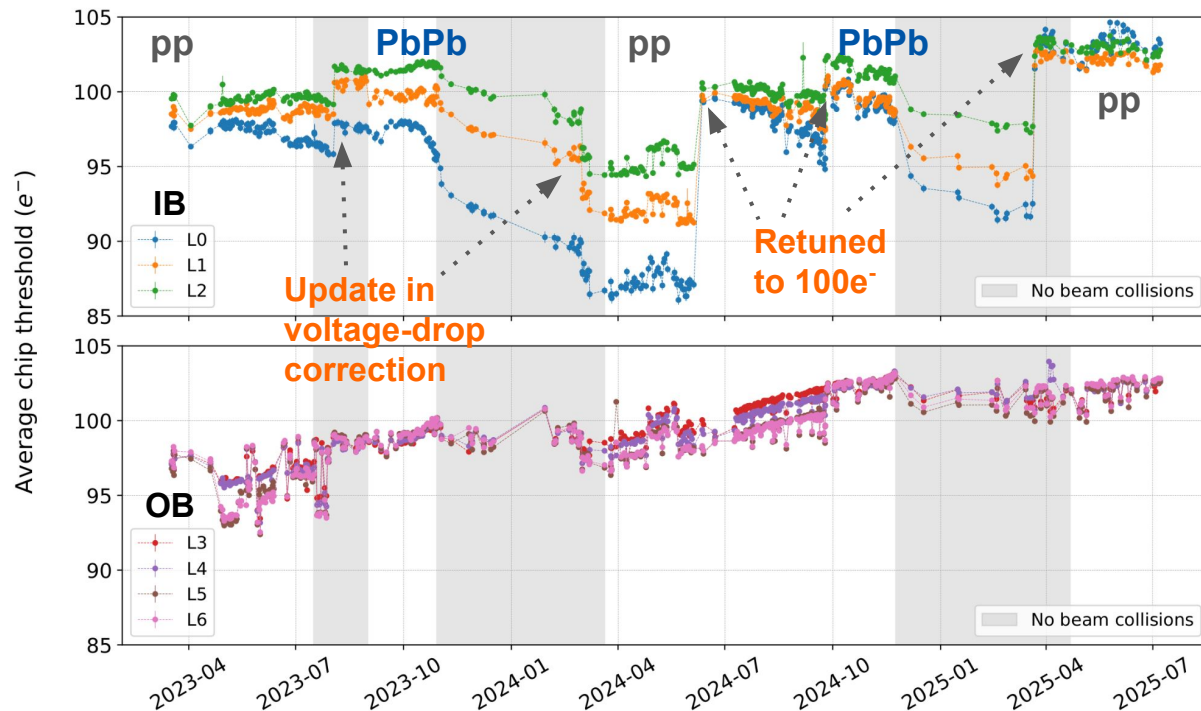

- Threshold measured between fills
- Threshold sensitive to analogue supply voltage ( $\sim -0.3 e^-/mV$ )
- Threshold sensitive to accumulated radiation dose
- Nominal threshold value set to  $100 e^-$ , at which the ALPIDE is known to be fully efficient
- Occasional re-tuning to  $100 e^-$
- Overall threshold stability is very high with good uniformity between chips

# Fake hit rate and detection efficiency

- Noise level has been regularly monitored and well under control with  $FHR \ll 10^{-6}$  hit/pixel/event
  - ▶ Noisy pixel masking  $\Rightarrow$  dedicated scans are performed to save the address of average noisy pixels
  - ▶ 0.015 % of pixels are masked in the total on the full detector
    - Two different cut values for noisy pixels in IB and OB
      - IB:  $10^{-2}$  hit/pixel/event  $\Rightarrow$  priority on detection efficiency
      - OB:  $10^{-6}$  hit/pixel/event  $\Rightarrow$  stricter masking of noisy pixels due to the limited bandwidth

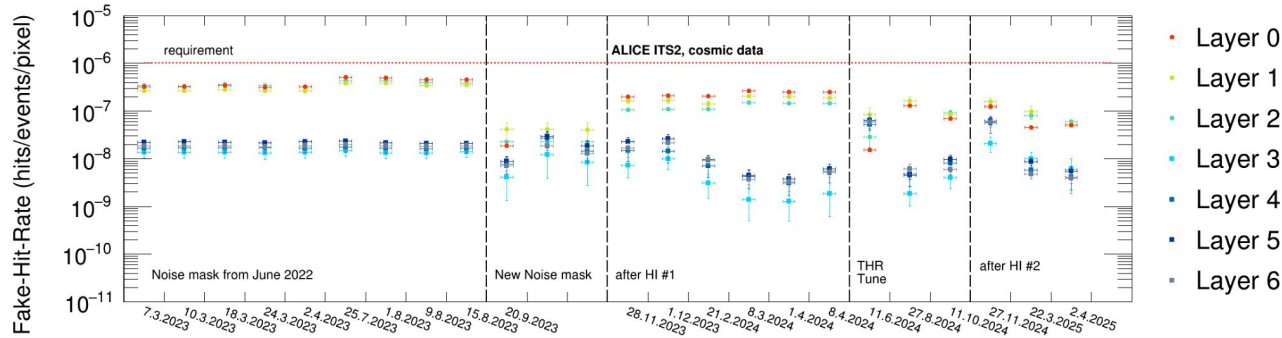

# Fake hit rate and detection efficiency

- Noise level has been regularly monitored and well under control with  $FHR \ll 10^{-6}$  hit/pixel/event
  - ▶ Noisy pixel masking  $\Rightarrow$  dedicated scans are performed to save the address of average noisy pixels
  - ▶ 0.015 % of pixels are masked in the total on the full detector
    - Two different cut values for noisy pixels in IB and OB
      - IB:  $10^{-2}$  hit/pixel/event  $\Rightarrow$  priority on detection efficiency
      - OB:  $10^{-6}$  hit/pixel/event  $\Rightarrow$  stricter masking of noisy pixels due to the limited bandwidth
- Detection efficiency measured using collision data with no magnetic field, exploiting hits in overlapping regions between adjacent staves
  - ▶ Efficiency above 99% in all IB layers

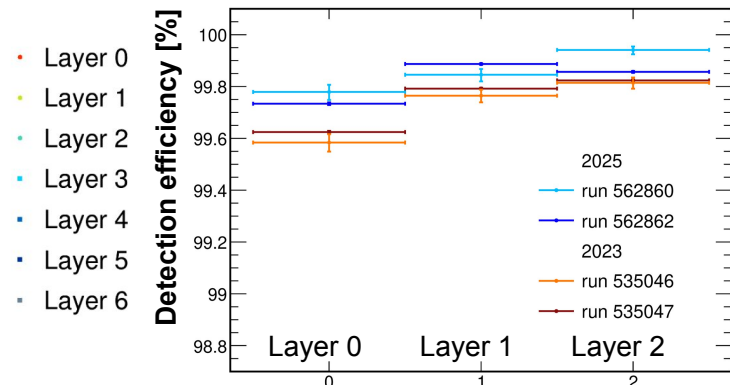
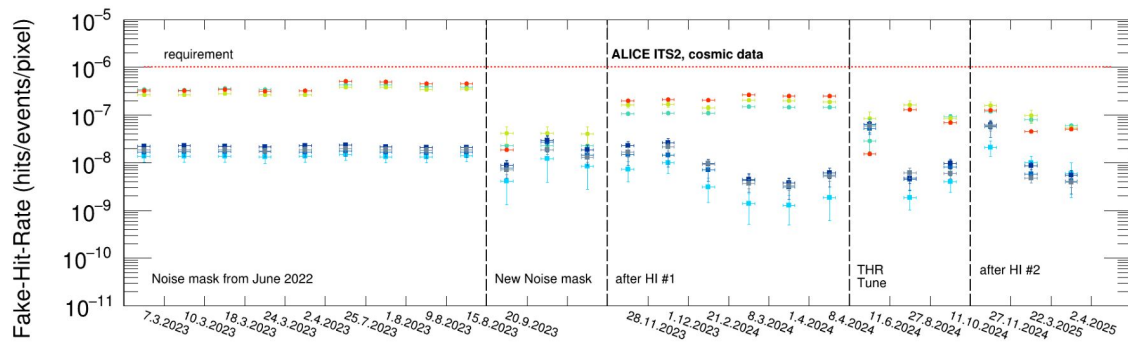

ALI-PERF-609519

# Beam background

Hitmap of one stave, L0\_04, showing a long cluster along the beam direction

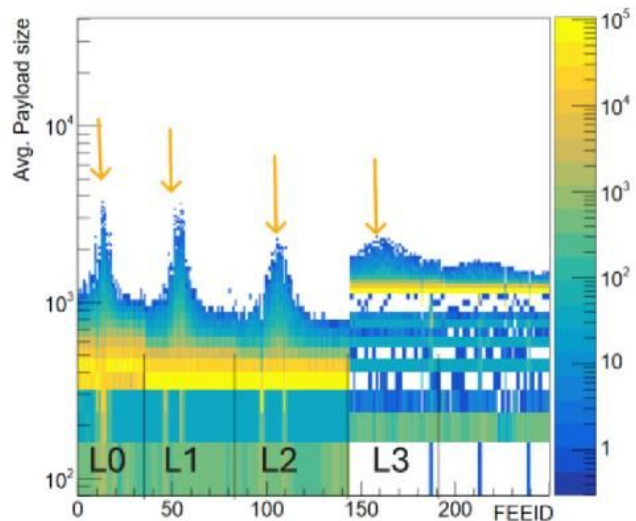
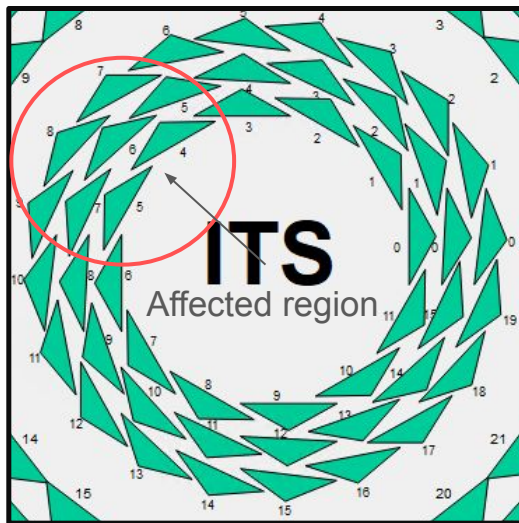

- Beam remnants traversing ITS at shallow angles cause very long clusters and high data load
- First observed in 2023 Pb–Pb at  $\phi = 2.4$  rad,  $r = 2-4$  cm (region not covered by ITS1)
- Identified and mitigated quickly with LHC experts (only 10% of 2023 data affected)
- Continuous monitoring and simulation studies ongoing for further understanding and future detectors

# Impact parameter resolution

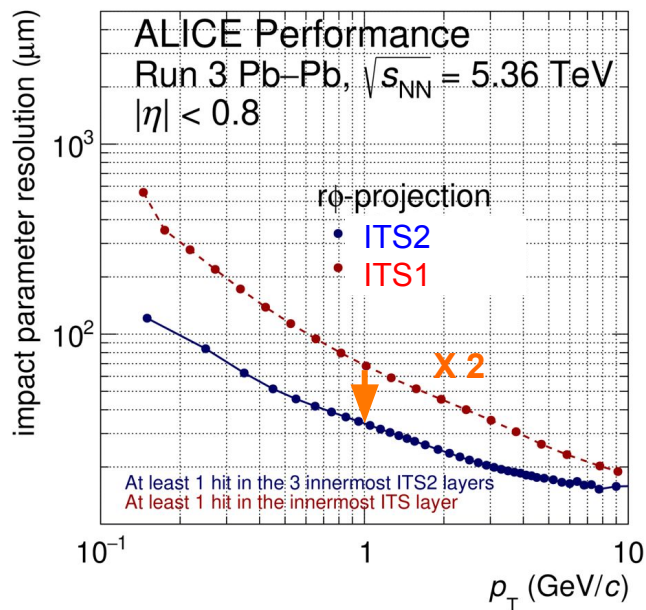

ALI-PERF-564335

$0.5 < p_T < 0.6$  GeV/c,  $\sigma_d$  impact parameter resolution ( $\mu\text{m}$ )

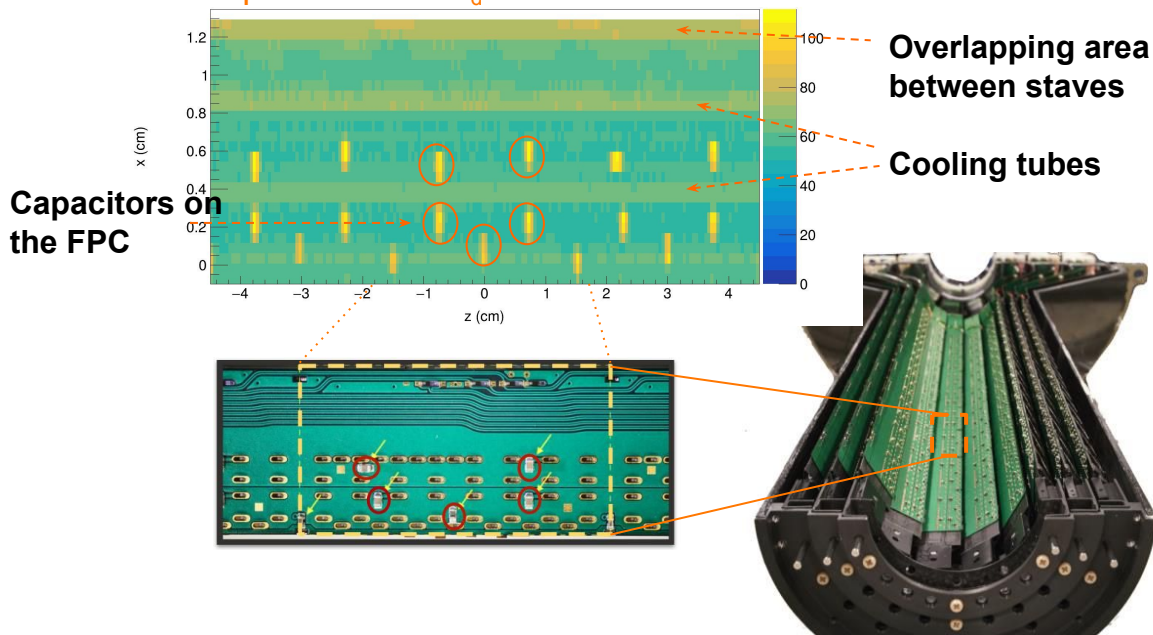

- Thanks to the improved impact parameter resolution in ITS2, detailed material composition of the first layer is clearly visible
- Improving detector description in simulations

# Physics performance in pp

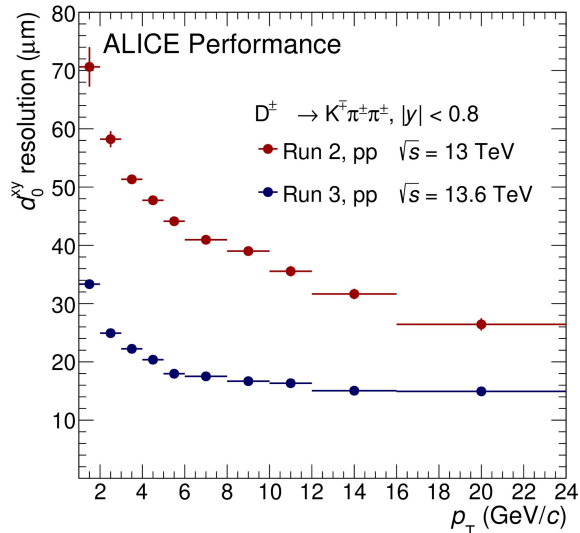
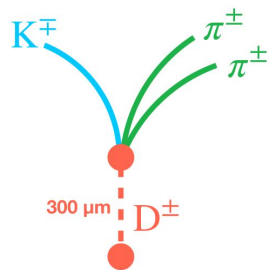

ALI-PERF-597787

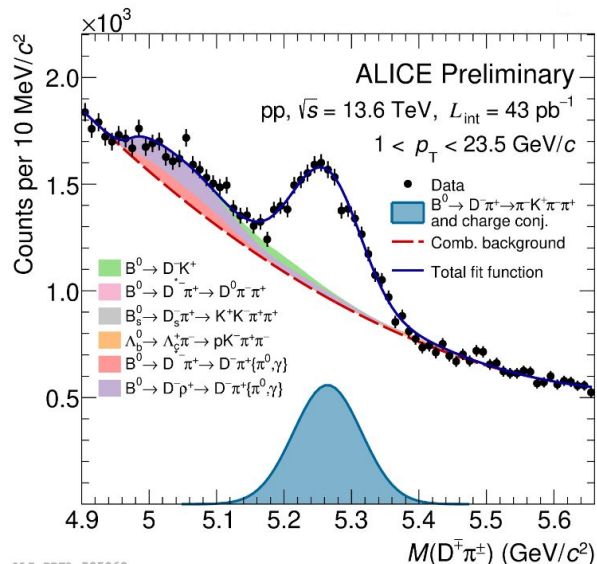

ALI-PREL-595060

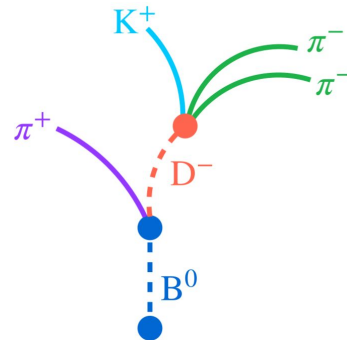

- Measurement of impact parameter of charmed  $D^\pm$  mesons
  - ▶ Significant improvement in impact parameter resolution compared to Run 2 (ITS1) with Run 3 (ITS2)
- Increased luminosity and clean separation between prompt/non-prompt D mesons enable full reconstruction of B mesons down to low  $p_T$

# Physics performance in pp - innovative strangeness tracking

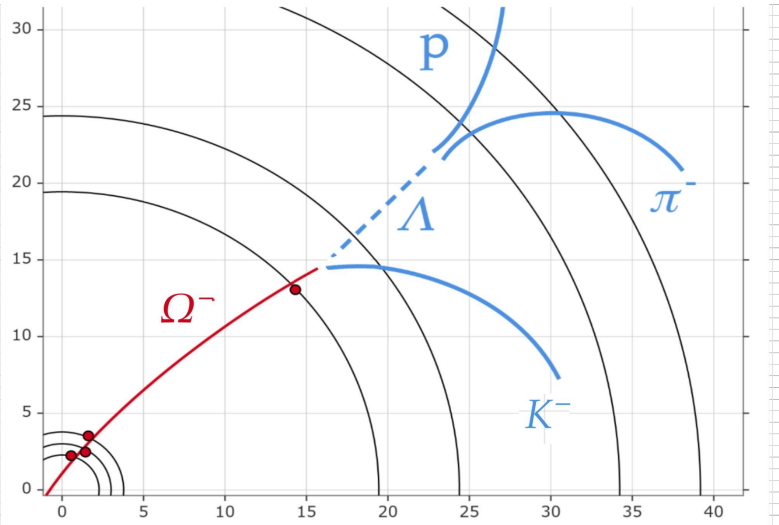

- **Tracking strange particles before their decay**
  - ▶ **Strangeness tracking algorithm:** to combine cascade decay topologies reconstructed in the outer ITS2 layers with track segments detected in the inner ITS2 layers

# Physics performance in pp - innovative strangeness tracking

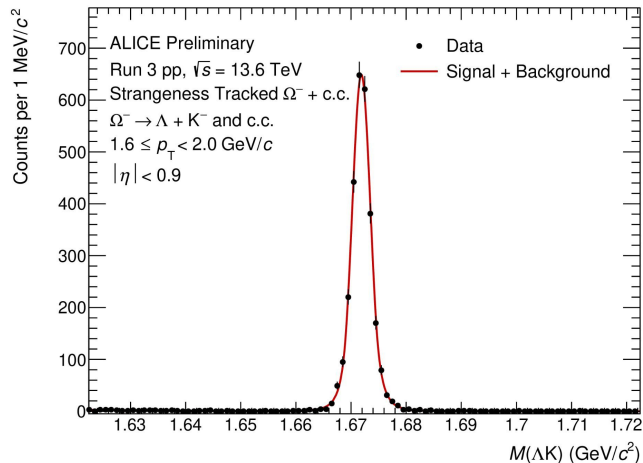
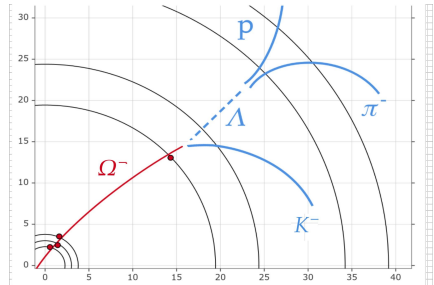

ALI-PREL-597891

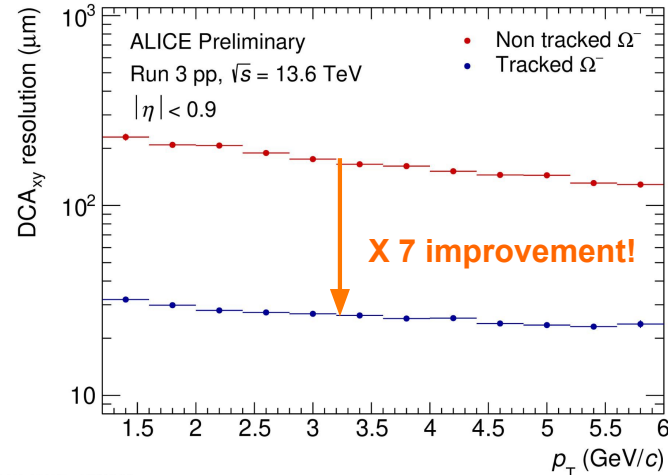

ALI-PREL-597901

## Tracking strange particles before their decay

- ▶ **Strangeness tracking algorithm:** to combine cascade decay topologies reconstructed in the outer ITS2 layers with track segments detected in the inner ITS2 layers
- ▶ Actual tracking of the  $\Omega^-$  in the innermost ITS2 layers  $\Rightarrow$  significant improvement in DCA resolution
- ▶ Strangeness tracking with improved DCA resolution allows us to measure the fraction of  $\Omega^-$ 's originating from  $\Omega_c^0$  decay
- ▶ Enables improved measurements of  $\Omega_c^0$  cross section, which are reconstructed from the  $\Omega_c^0 \rightarrow \Omega^- \pi^+$  decay

# Physics performance in Pb–Pb

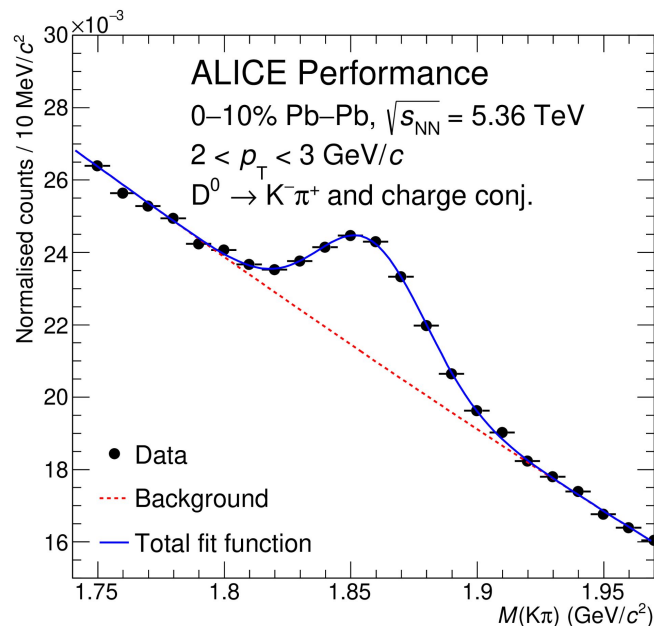

ALI-PERF-568645

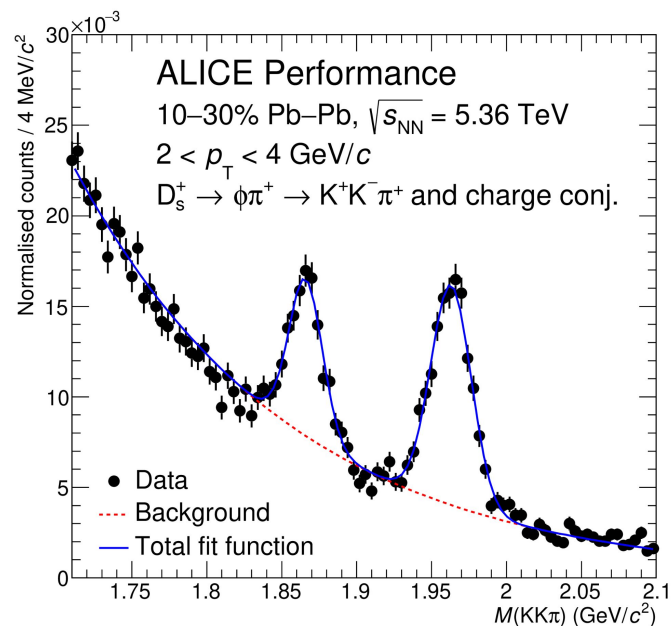

ALI-PERF-568632

- Demonstrate good performance of weak-decaying particle in the high density environment, Pb–Pb, down to the low  $p_T$

# Particle identification with ALPIDE - ITS Color run

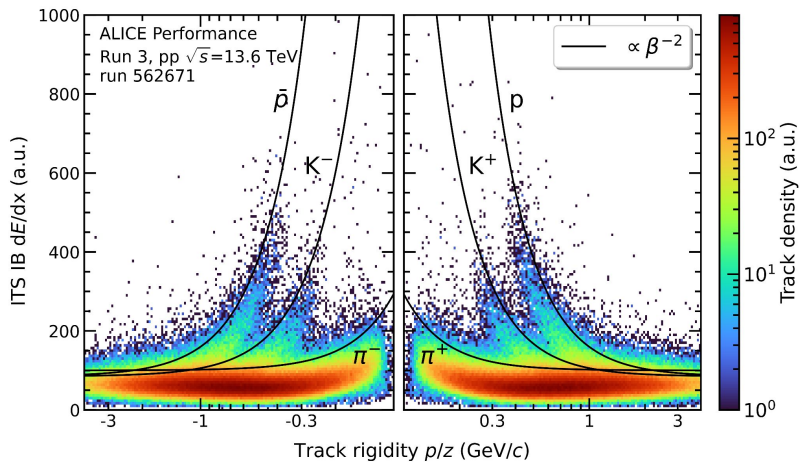

- Usage of Time over Threshold (ToT) information to access the particle energy loss in the ALPIDE sensitive layer
- Proof of concept of  $dE/dx$  measurement with binary readout MAPS
- Oversampling with increased framing rate to obtain accurate ToT information proportional to deposited charge

- Detector parameters during color run
  - Only feasible at low Interaction rate in p-p
  - High readout rate (2.2 MHz)
  - Deactivation of signal clipping
    - Obtain pulse length proportional to deposited charge
  - Note: this is a special run with unique settings which is not viable for nominal operation

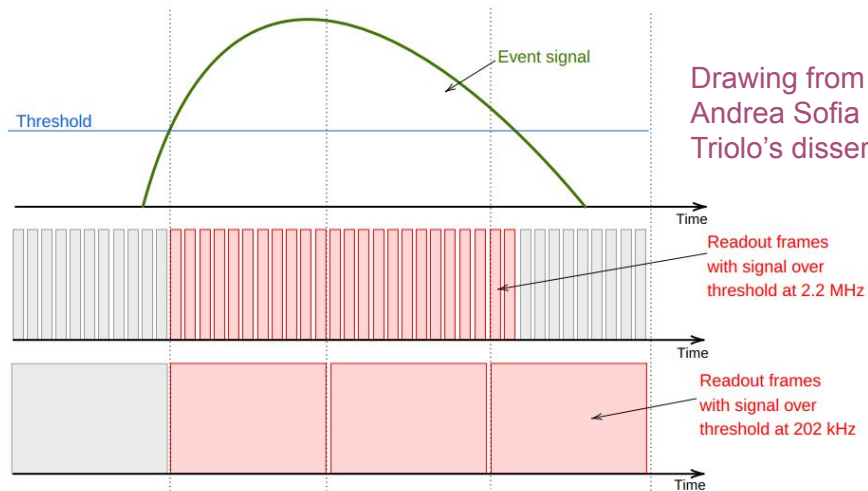

Drawing from  
Andrea Sofia  
Triolo's dissertation

# Summary

## ITS2 has demonstrated excellent performance:

- Largest MAPS-based detector in HEP: **stable operation since 2022 with increased readout rates (202 kHz / 67 kHz) compared to ITS1 (1 kHz)**
  - ▶ Robust operation and monitoring framework with DCS, readout system, and QC
- **Detection efficiency > 99 % and fake hit rate  $\ll 10^{-6}$  /pixel/event** over 3 years of operation
- **Beam background and material composition effects** were observed and further study is ongoing
- **Impact parameter resolution improved by a factor of 2** compared to ITS1:
  - ▶ With increased statistics in all collision systems, ITS2 contributes to precision measurements of heavy-flavor hadrons
  - ▶ Strangeness tracking in ITS2 layers allows exploration of previously inaccessible decay channels like  $\Omega_c^0 \rightarrow \Omega^- \pi^+$
- **Particle identification capability using Time over Threshold (ToT) information - ITS Color run**

# ITS3 - the next step

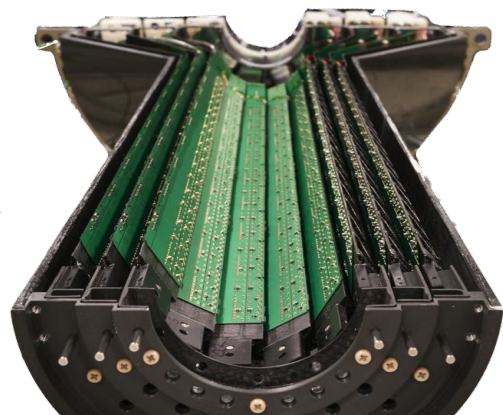

**Material budget: 0.36 %  $X_0$**

Replacing the IB with

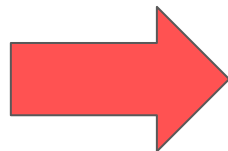

**Material budget: 0.09 %  $X_0$**

# ITS3 - the next step

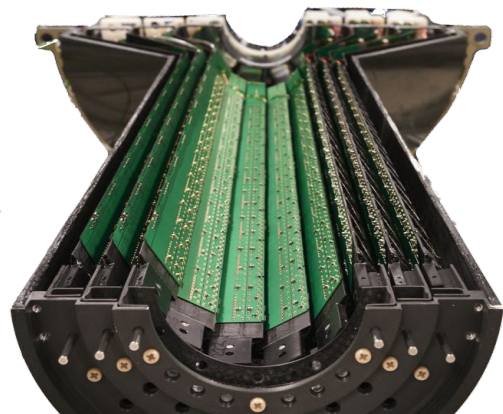

Material budget: 0.36 %  $X_0$

Replacing the IB with

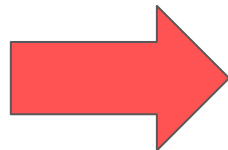

Material budget: 0.09 %  $X_0$

- [ALICE Inner Tracking System 3 overview](#) - Aug 25th (today), at 16:30, by Livia Terlizzi
- [Monolithic active pixel sensors based on the TPSCo 65 nm imaging CMOS technology](#) - Aug 26th (Tuesday) at 10:00, by Giacomo Ripamonti
- [ALICE ITS3 MOSAIX stitched wafer-scale sensor](#) - Aug 26th (Tuesday), at 15:00, by Jelena Lalic

A photograph showing the interior of the ALICE detector, a large cylindrical structure with a complex, multi-layered design. The walls are covered in a dense array of gold-colored components, likely part of the particle tracking system. The perspective is from the center of the detector, looking down a long, narrow passage towards a bright light source at the far end.

**Thank you for  
listening**