

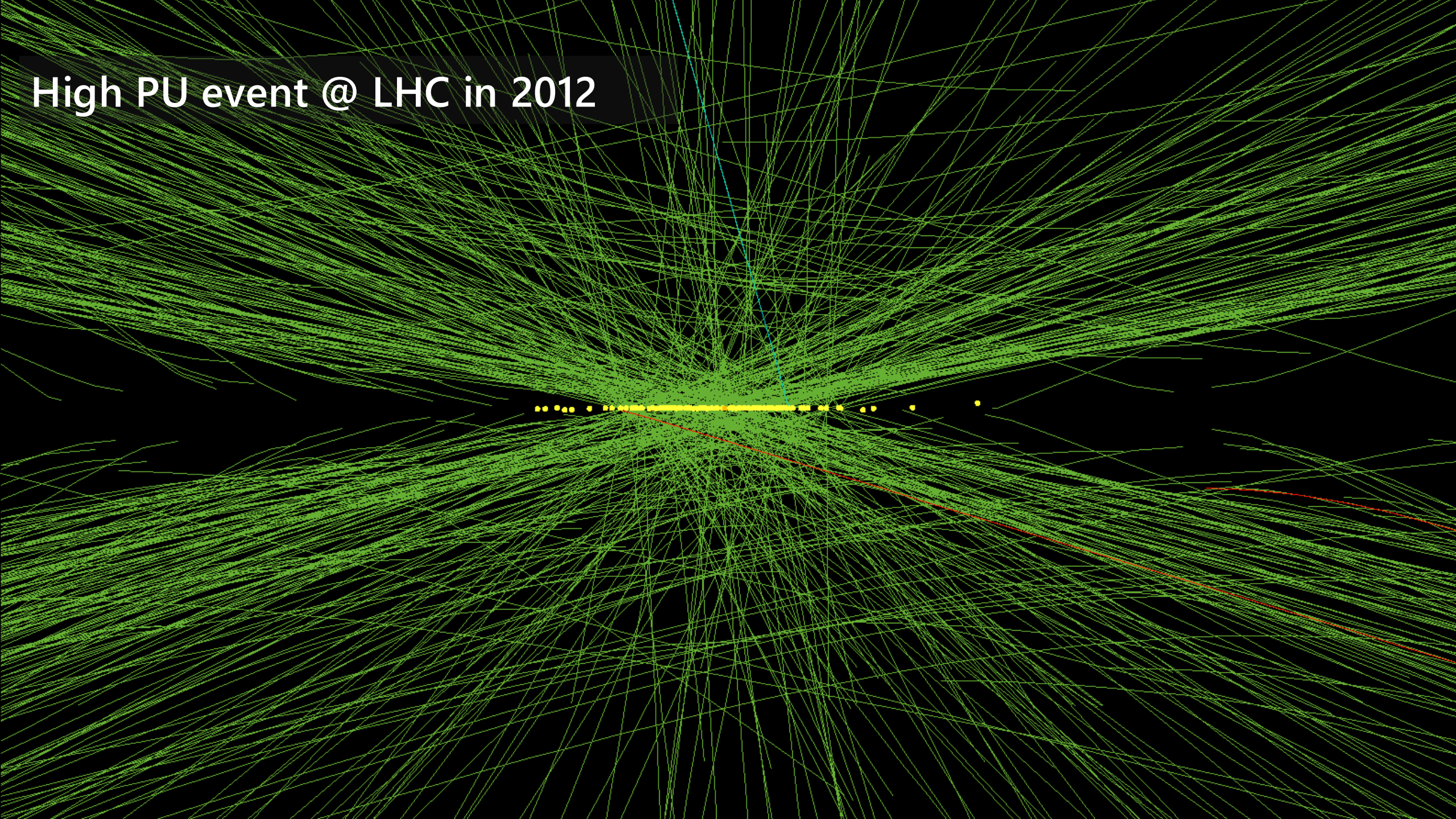

# The CMS Tracker Upgrade for Phase-2: meeting the challenges of the HL-LHC

Matteo Magherini  
on behalf of the CMS Group

High PU event @ LHC in 2012



High PU event @ LHC now

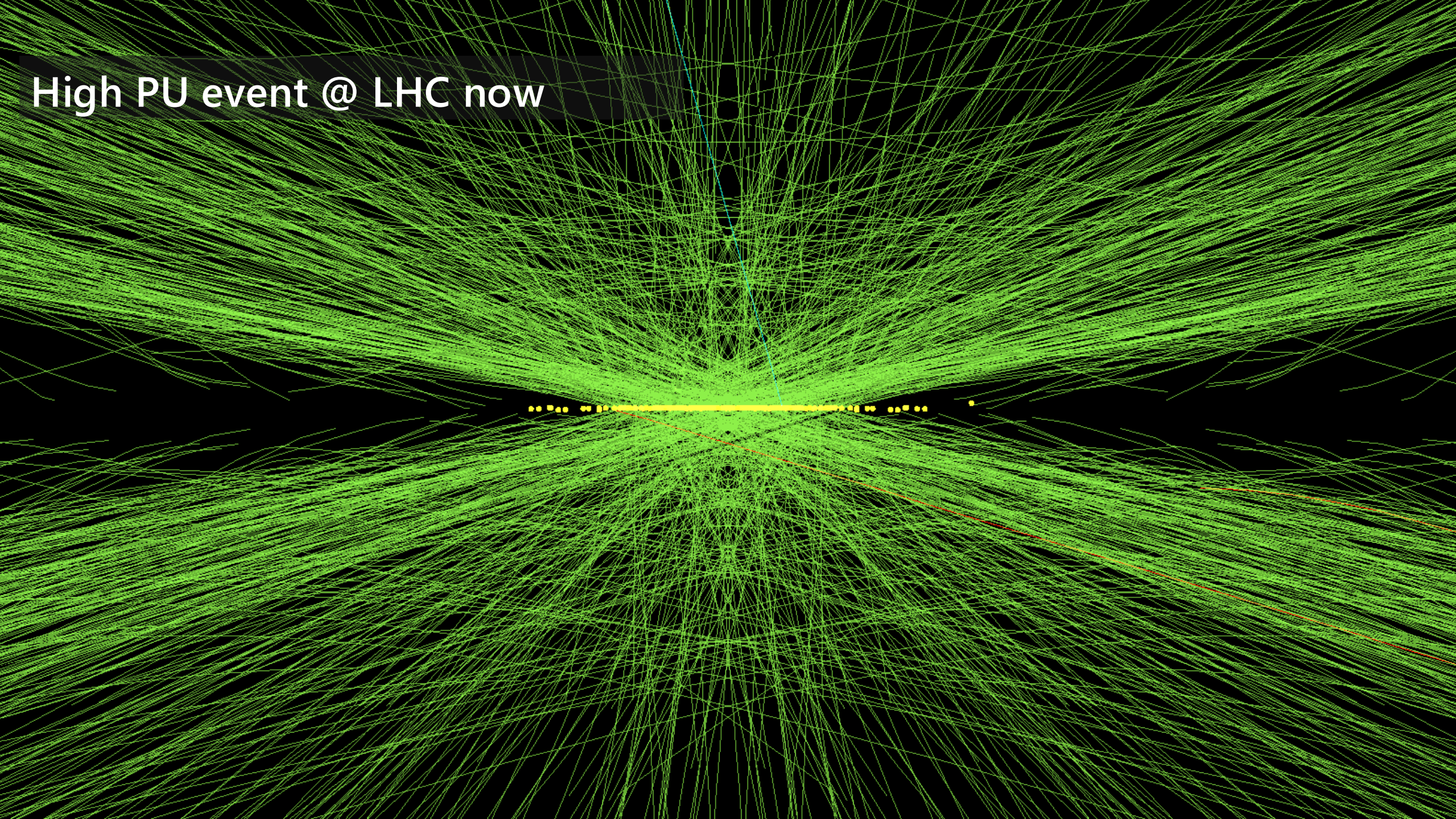

Average event @ HL-LHC

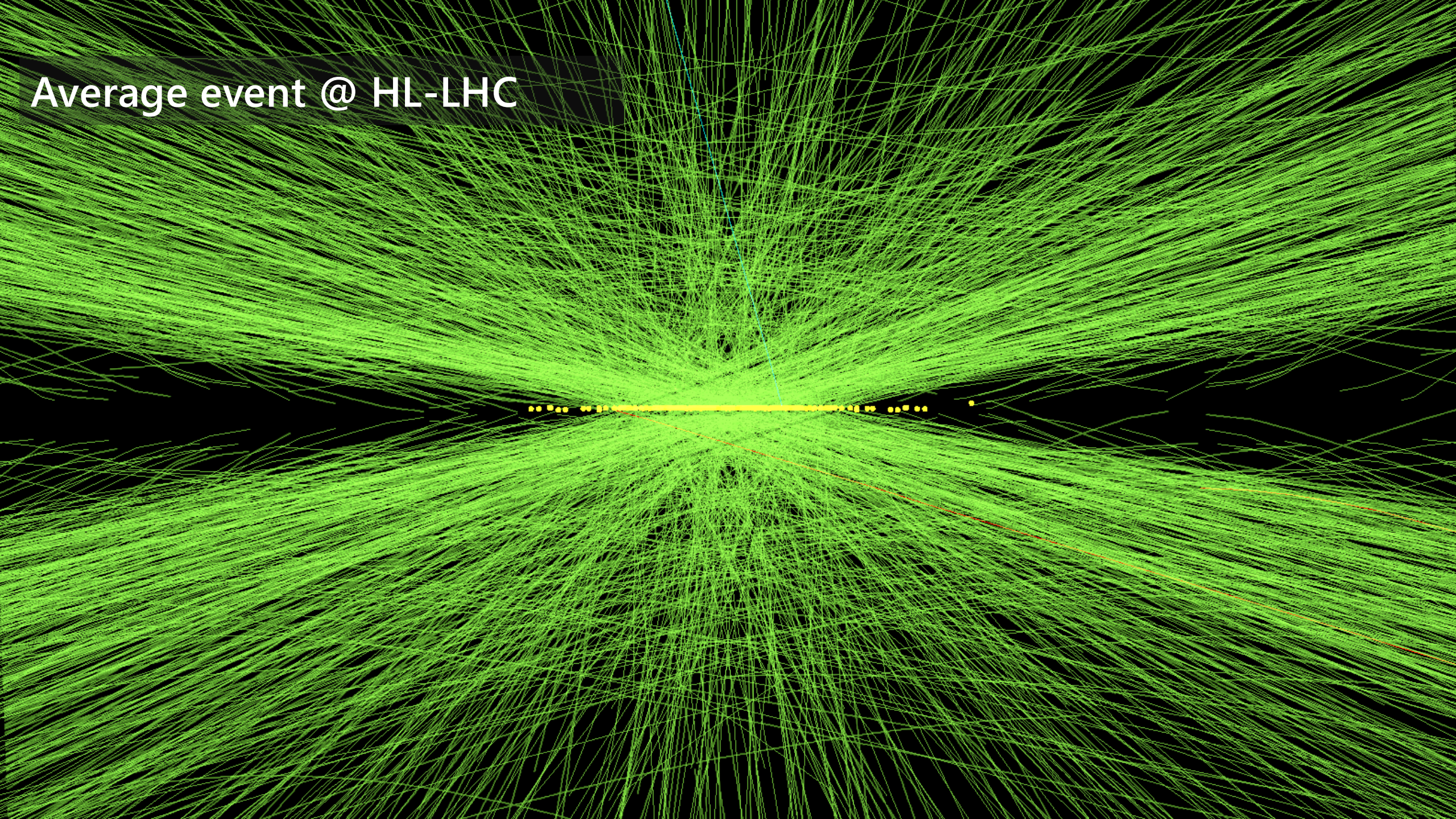

## Average event @ HL-LHC

- Expected Pile-up: 200 events/25 ns  $\sim 4$  times LHC
- Instantaneous peak luminosity:  $5-7.5 \times 10^{34} \text{cm}^{-2}\text{s}^{-1}$ :  $\sim 4$  times LHC
- Dose & fluence  $\sim 10$  times LHC

# High Luminosity requirements

- **Radiation tolerance:** full efficiency up to  $3000 \text{ fb}^{-1}$
- **Reduced material budget:** calorimeters and overall event reconstruction performance enhancement
- **Extended tracking acceptance:** meets CMS physics program needs
- **Increased granularity:** efficient tracking with high PU level
- **Contribution to L1 trigger:** anticipate selection to mitigate inefficiencies from high pileup

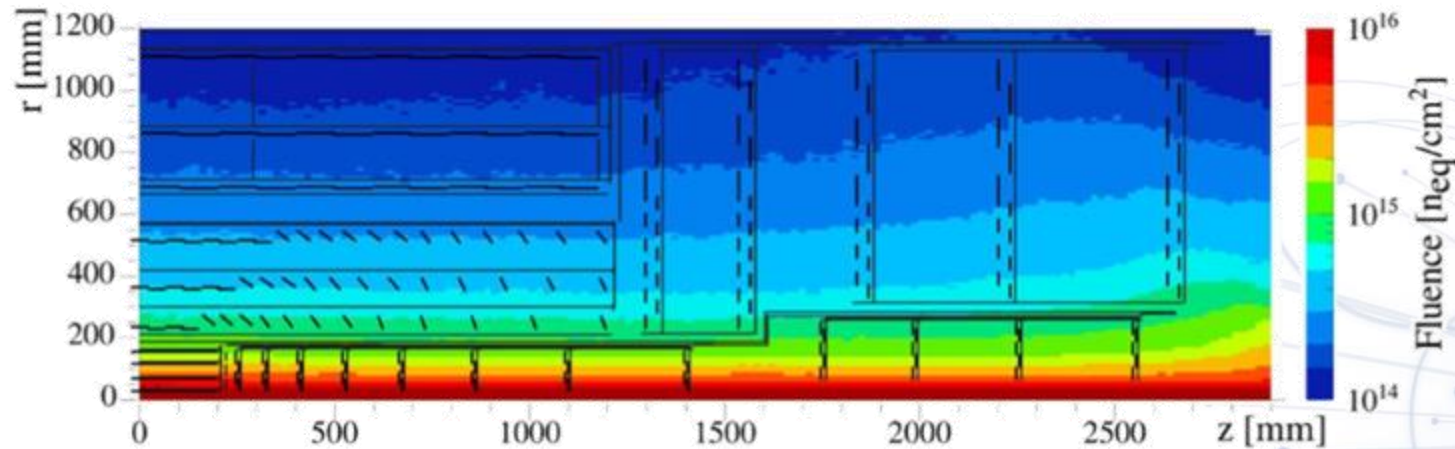

# Current CMS Tracker Limitations

- End of Run 3: strip tracker **overloaded by radiation damage** (leakage current & full depletion voltage limitations)
- Occupancy: would need **higher granularity** to cope with HL-LHC 4x higher rate
- Readout: impossible to **contribute to L1 trigger**



**Full tracker replacement!**



# Ph2 CMS Tracker – Outer Tracker Contribution to L1 Trigger

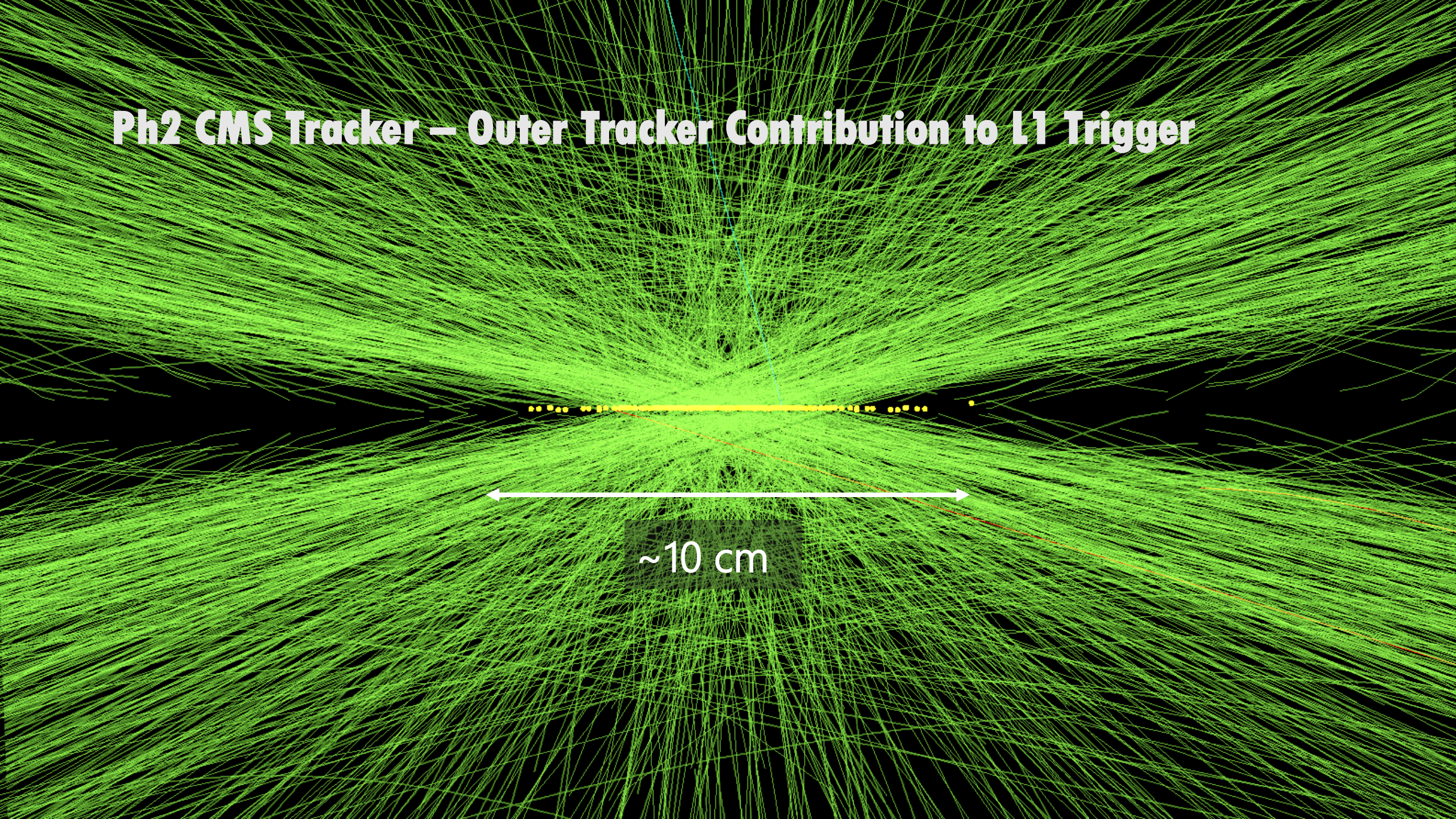

~10 cm

# Ph2 CMS Tracker – Outer Tracker Contribution to L1 Trigger

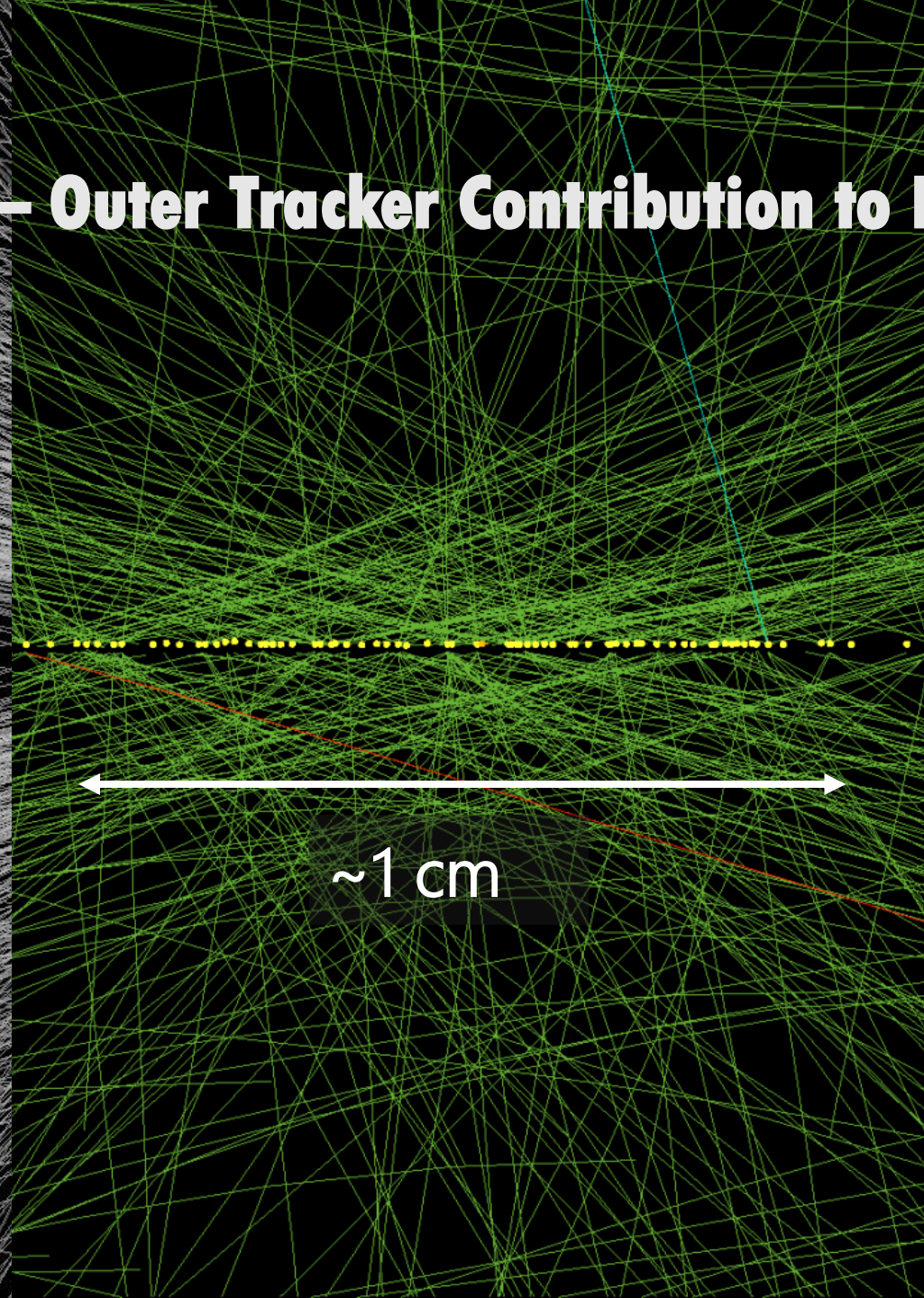

# Ph2 CMS Tracker – Outer Tracker Contribution to L1 Trigger

- Contribution to L1 trigger via track reconstruction from **Outer Tracker**
- 750 kHz L1 trigger rate  $\sim 7$  times LHC
- 12.5  $\mu$ s L1 latency
- Resolution of approx 1 mm
- Allows us to mitigate Pile-Up combinatorics by two orders of magnitude

$\sim 0.1$  cm

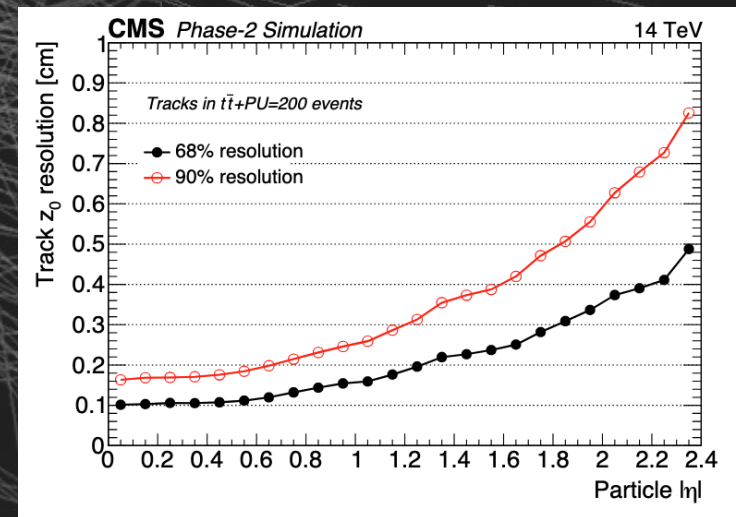

# Ph2 CMS Tracker – Performance

- **Improvement in resolution** with the whole tracker
- High tracking efficiency @ 200 PU and low Fake Rate

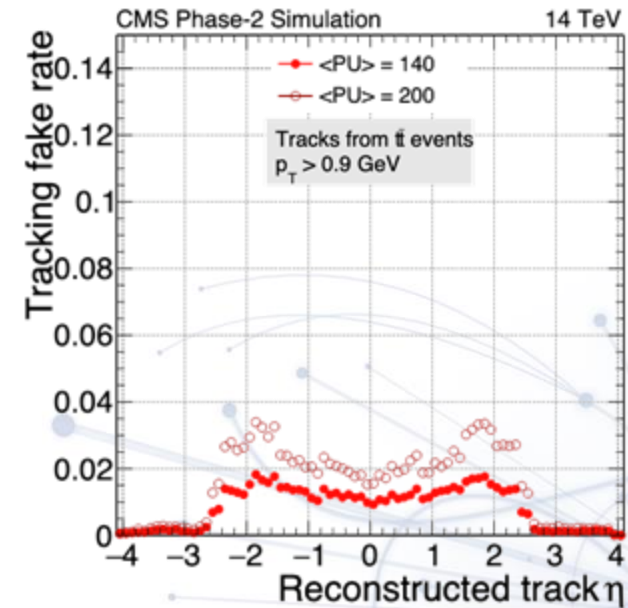
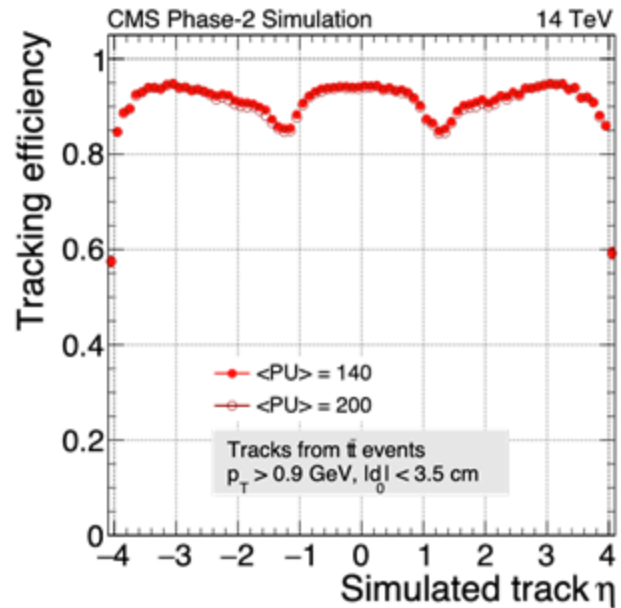
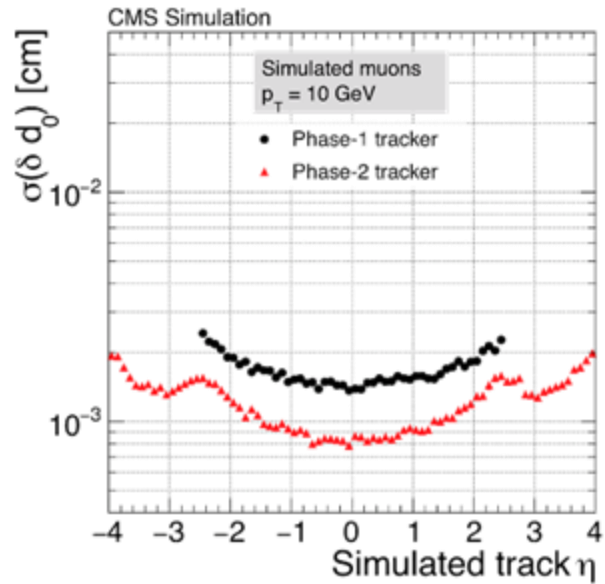

# Ph2 CMS Tracker – Material budget

- Lighter materials, CO2 cooling, optimized service routing

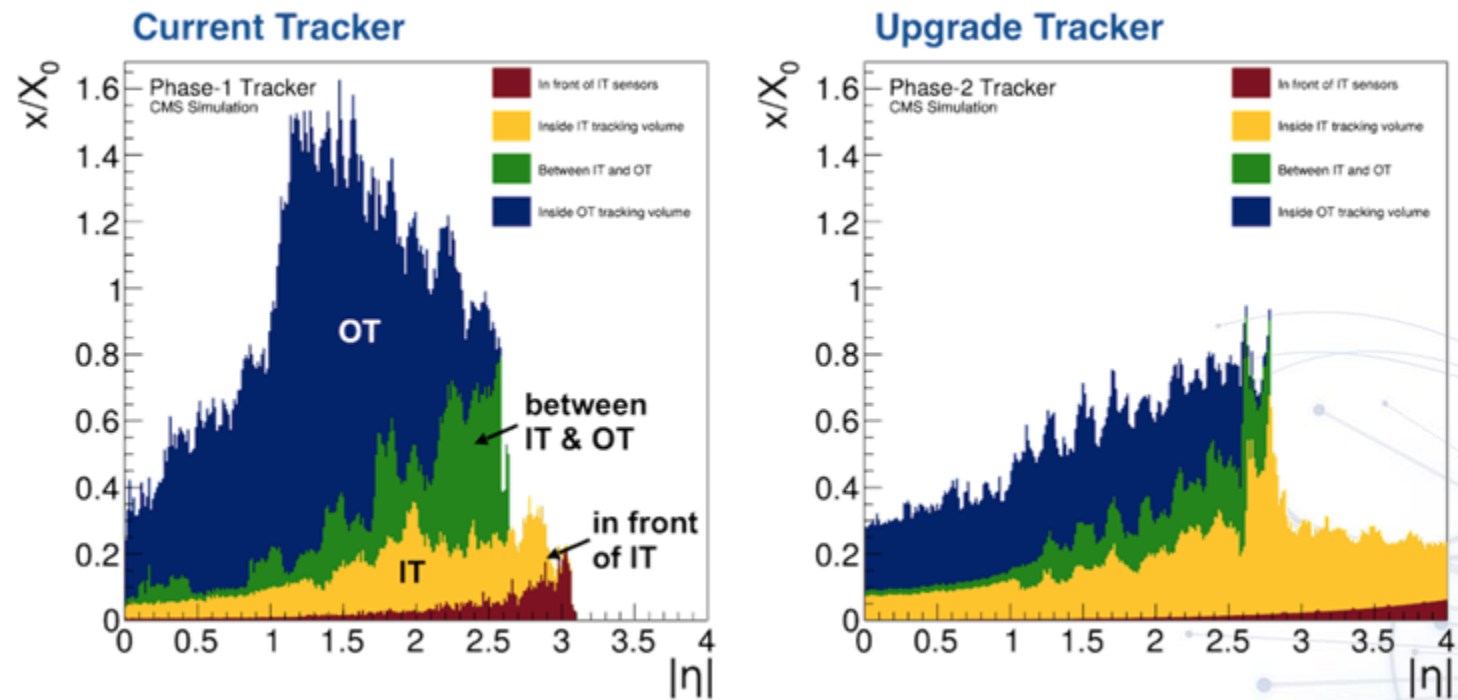

# From Phase 1 to...

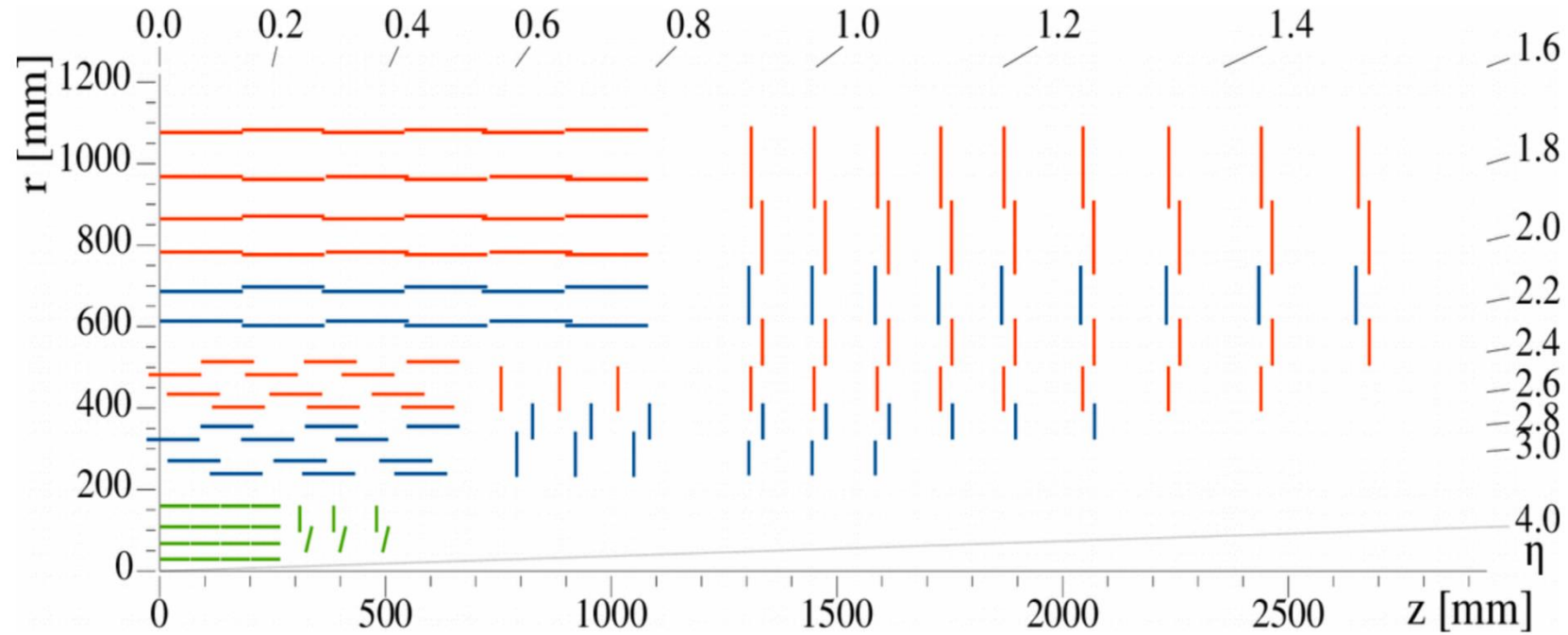

# Phase 2 Tracker

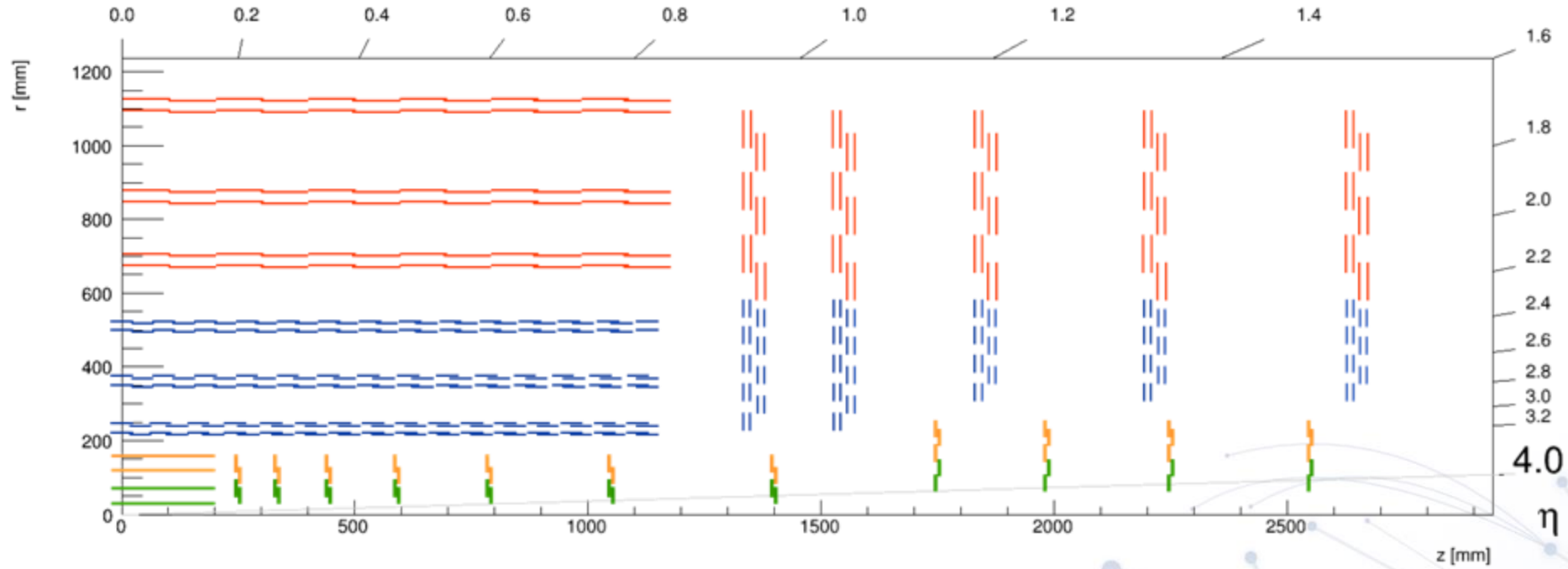

# Inner Tracker

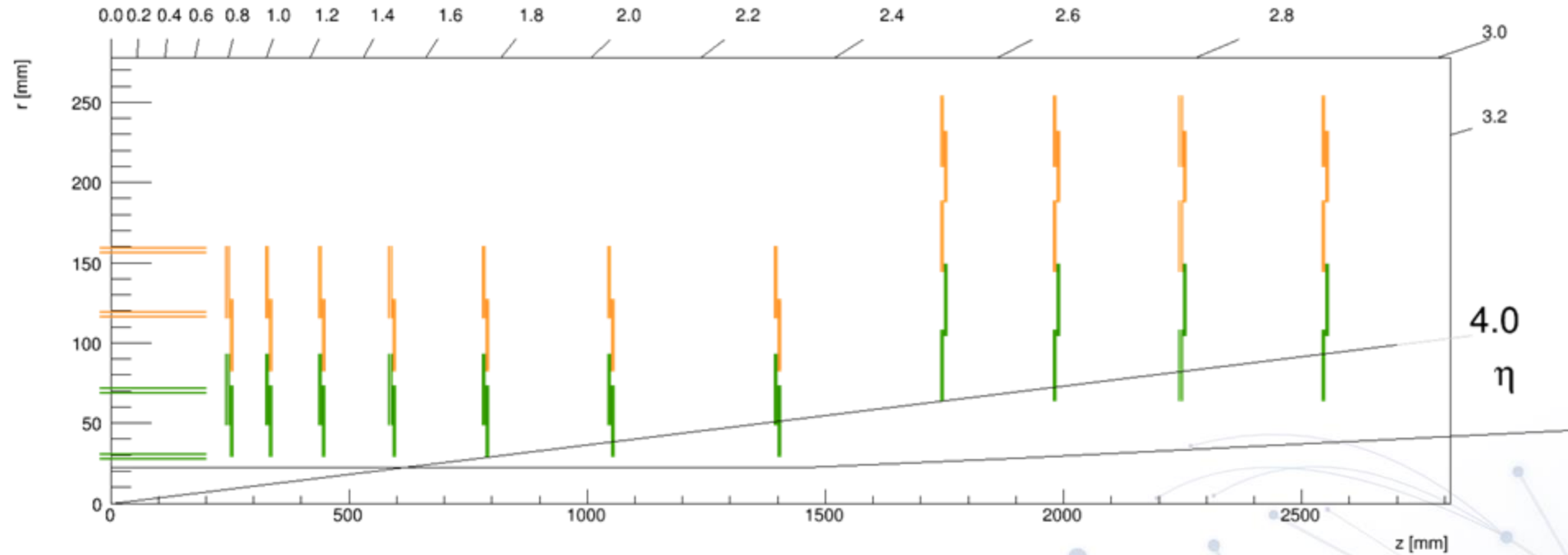

# Inner Tracker – Tracker Barrel Pixel (TBPX)

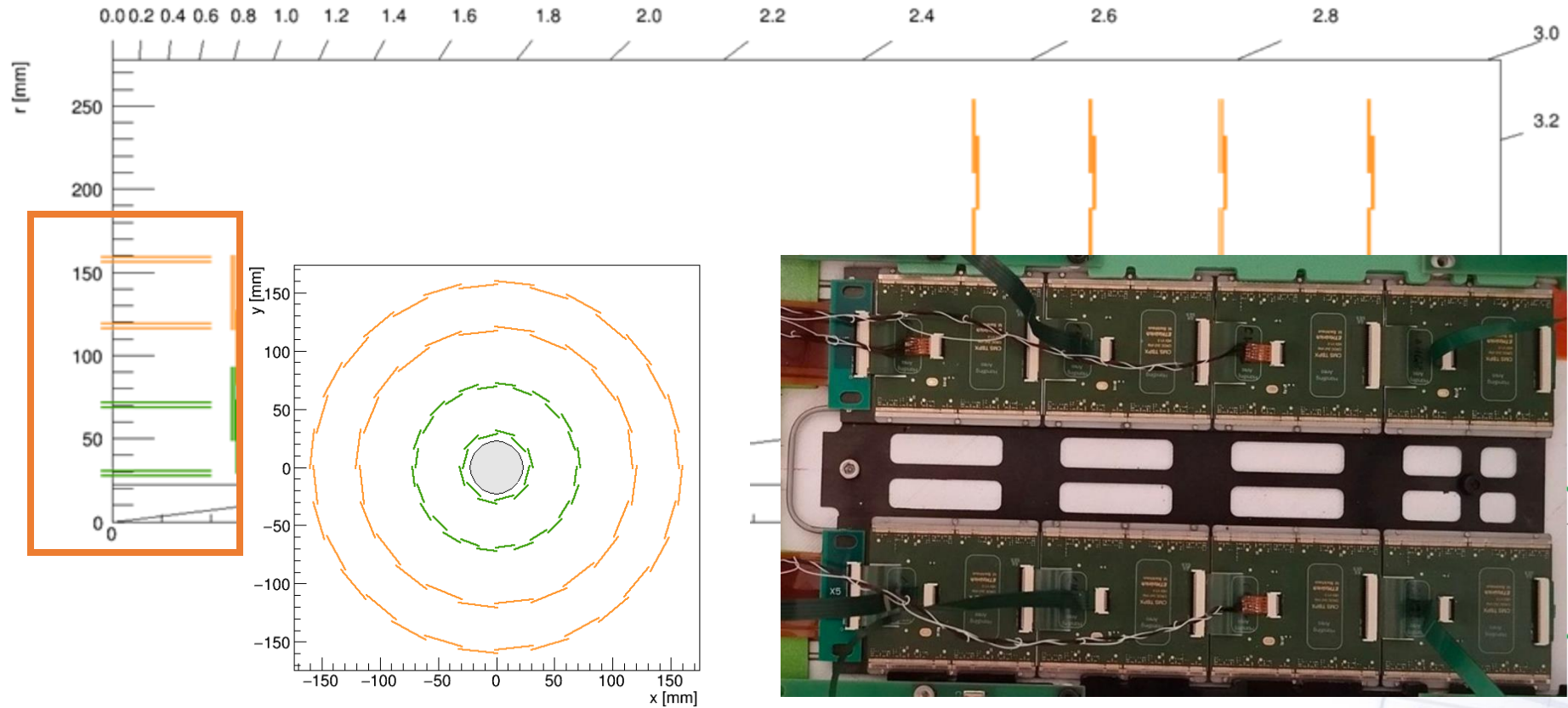

# Inner Tracker – Tracker Forward Pixel (TFPX)

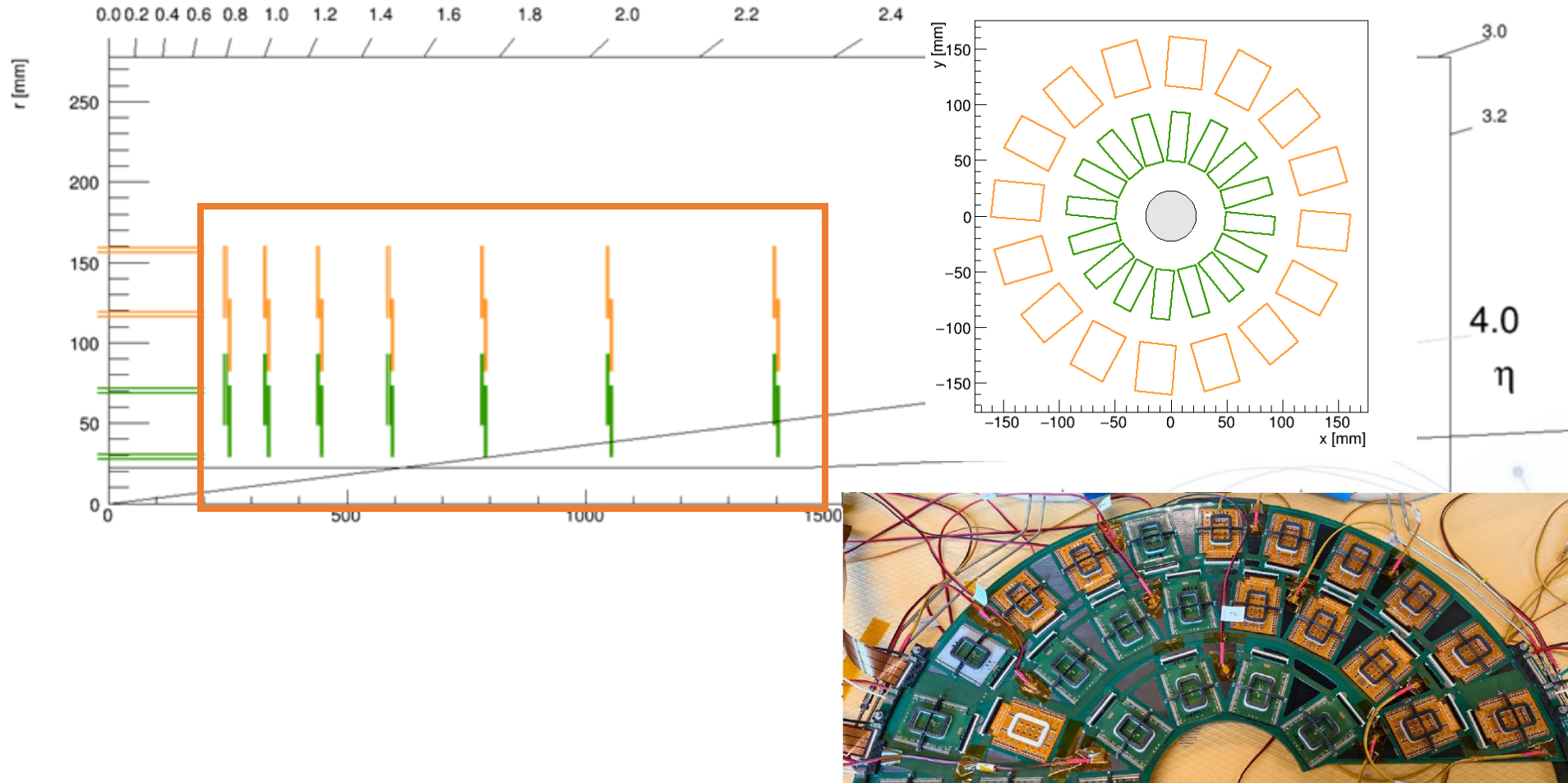

# Inner Tracker – Tracker Endcap Pixel (TEPX)

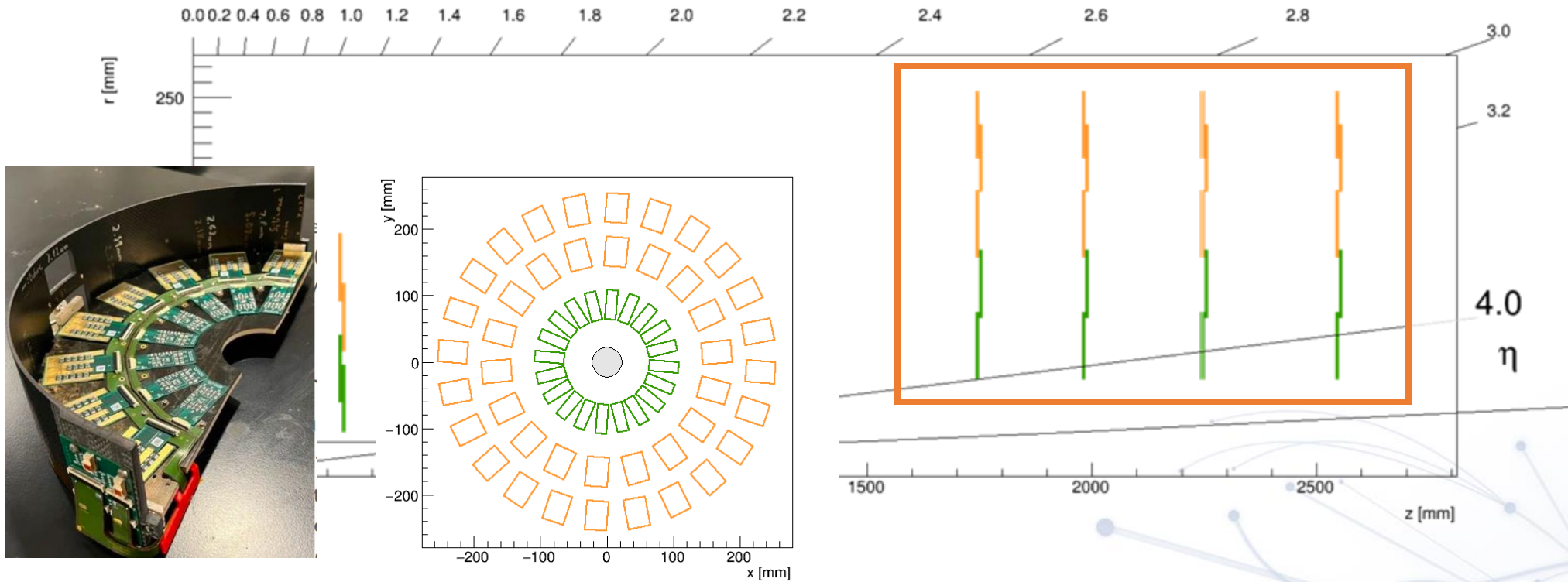

# Mechanical Support

Details on mechanics:  
Pierre Rose's [talk](#) on Wednesday!

- Carbon fibre structures with embedded cooling pipes
- Flat disk geometry (replaces turbine design)
- CO<sub>2</sub> evaporative cooling at  $-35\text{ °C}$  via 1.8 mm stainless steel pipes (168 loops)

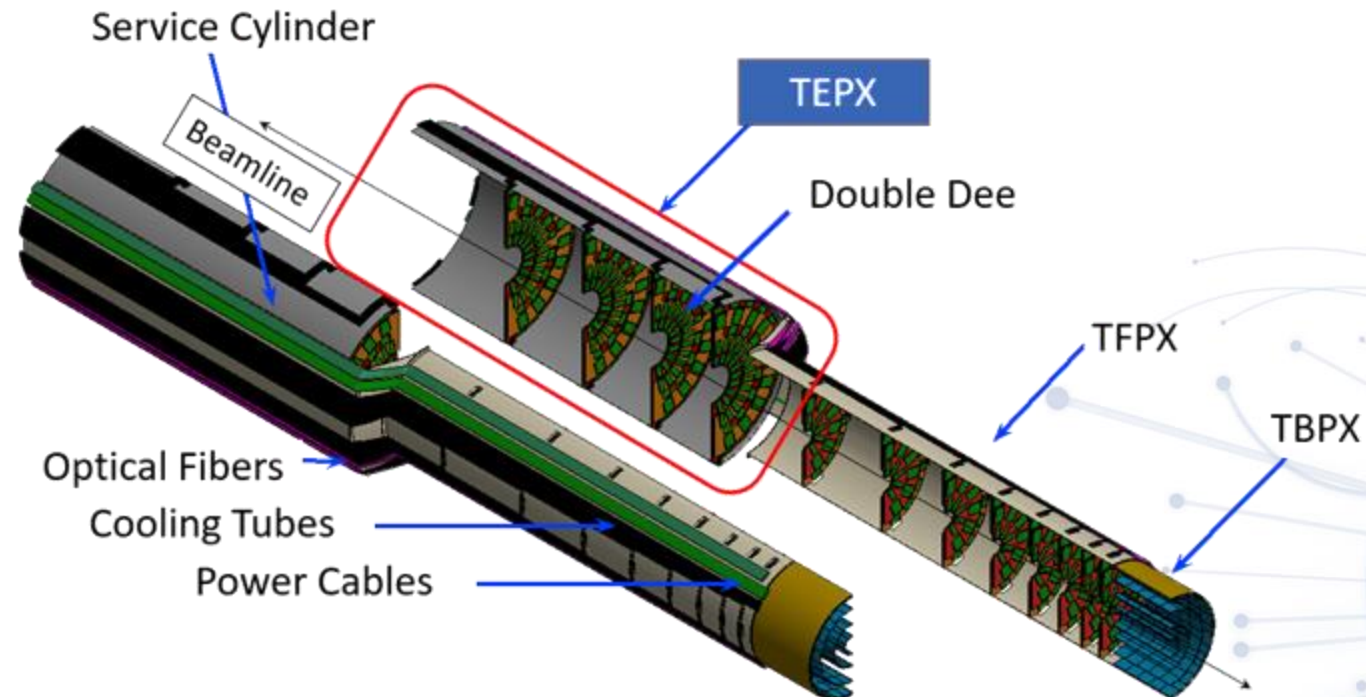

# IT sensors

- Planar:

- $25 \times 100 \mu\text{m}^2$  per  $150 \mu\text{m}$  active thickness
- Bitten implant, no punch-through bias dot
- Hit efficiency  $>99\%$  after  $2 \times 10^{16} n_{\text{eq}}/\text{cm}^2$

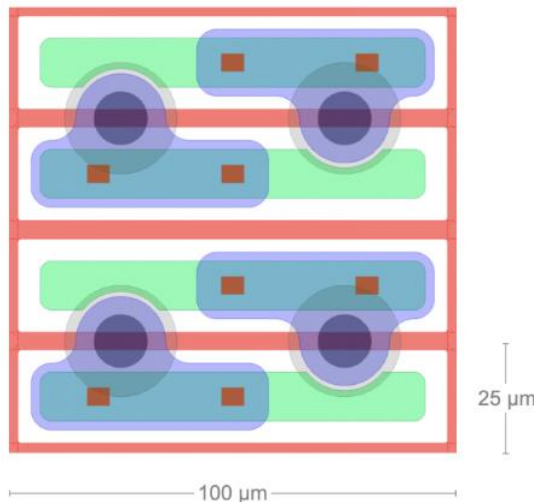

- 3D sensors:

- Better performances for radiation damage
- Lower depletion voltage
- Hit efficiency  $>98\%$  after  $1.8 \times 10^{16} n_{\text{eq}}/\text{cm}^2$

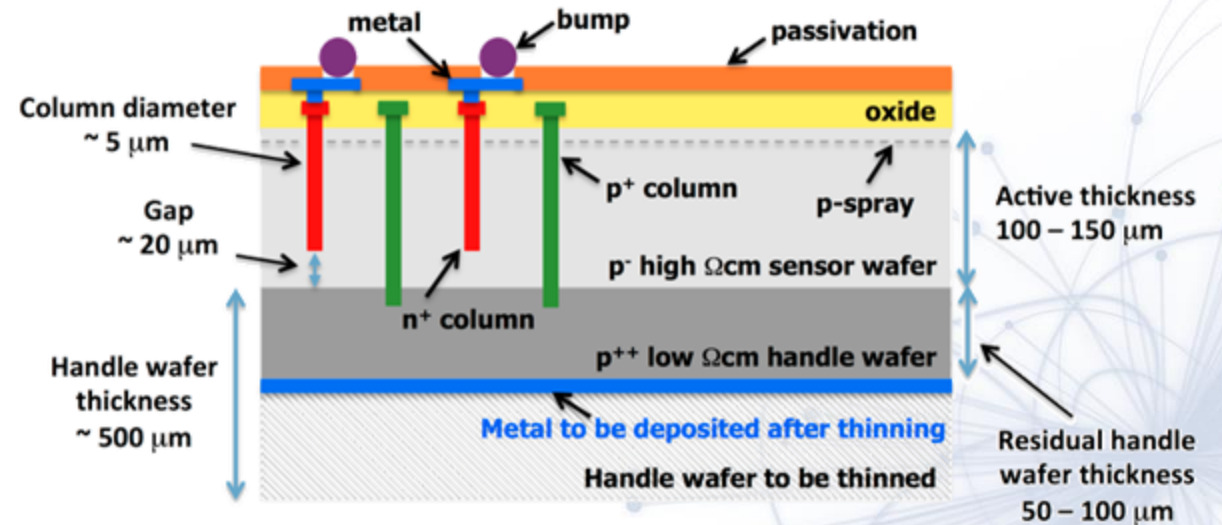

# CMS Readout Chip (CROC)

- ASIC based on CMOS 65nm technology (CERN RD53 project) → **CMS flavor of RD53 ROC**: C-ROC
- **Radiation tolerant** up to 1 Grad
- **Low power consumption**  $< 1 \text{ W/cm}^2$
- Trigger rate of 750 kHz
- Output bandwidth 1-4 x 1.28 Gbps
- **Analog FE linear architecture** (ToT linear wrt charge)
- 4 bit digital readout with selectable 6-to-4-bit dual slope ToT mapping for charge compression (elongated clusters, heavy ionizing particles)



# IT + BRIL test beams

- 2024 joint test beam between CMS Luminosity Group (BRIL) and Inner Tracker → read out CROC v1 **with legacy DAQ board**

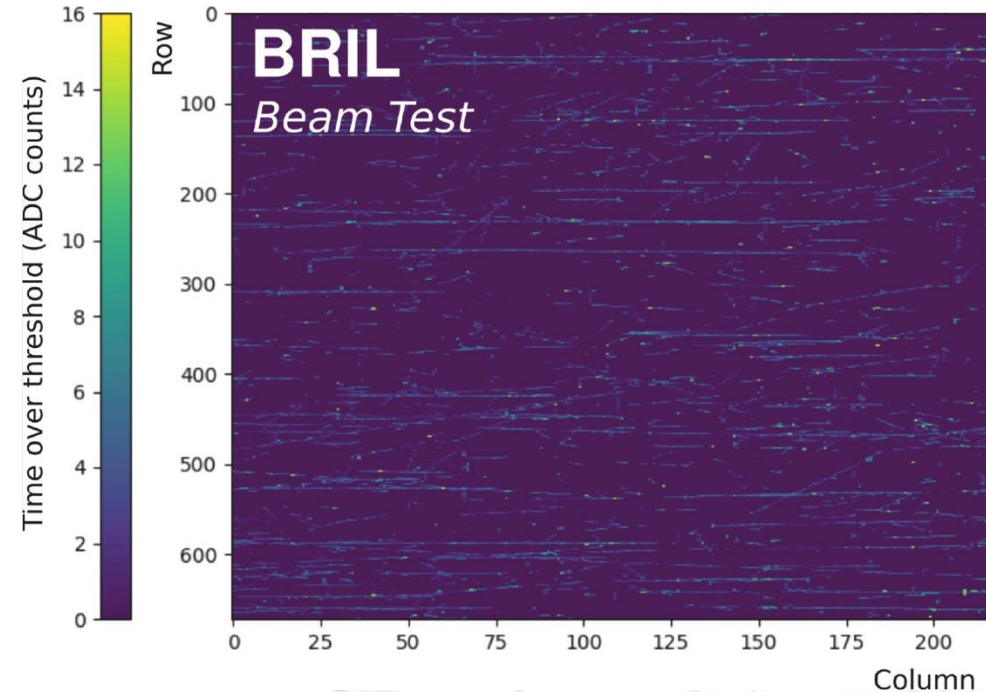

Accumulated long clusters (tracks) in the Si-pixel module with its plane rotated by 5° with respect to the [beamline](#). The color indicates the uncalibrated 4-bit time over threshold values that the counters output.

Ref: <https://doi.org/10.1016/j.nima.2025.170663>

# IT + BRIL test beams

- 2024 joint test beam between CMS Luminosity Group (BRIL) and Inner Tracker → read out CROC v1 **with legacy DAQ board**
- Ongoing (now!) joint IT + BRIL TB → first time **DAQ with final board!**

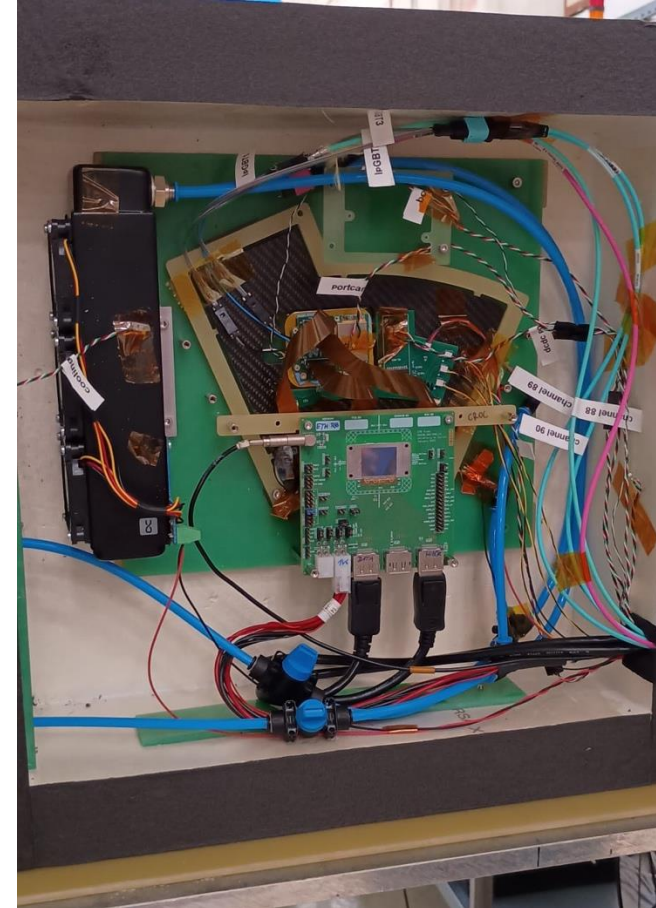

# IT Modules

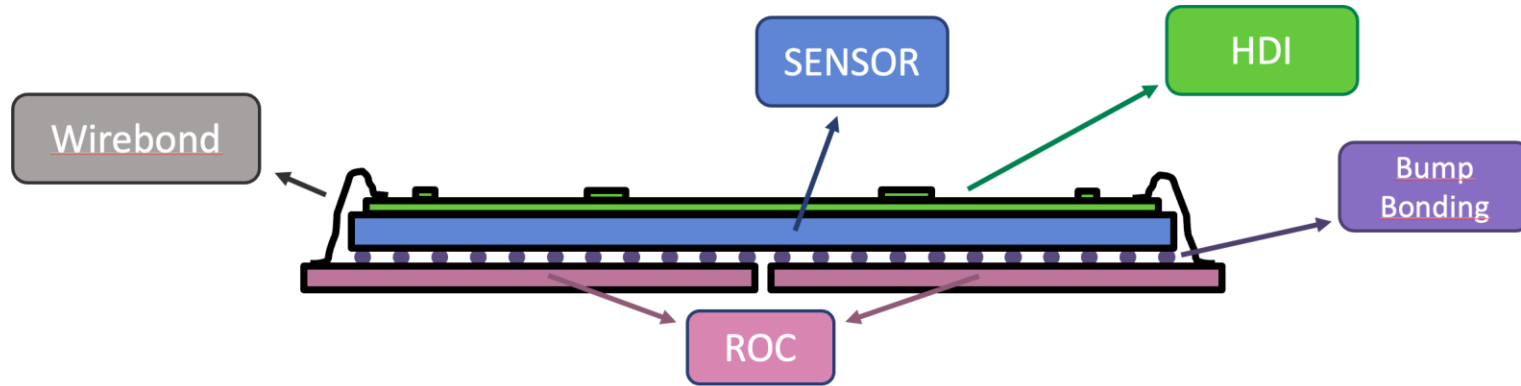

1x2

2x2

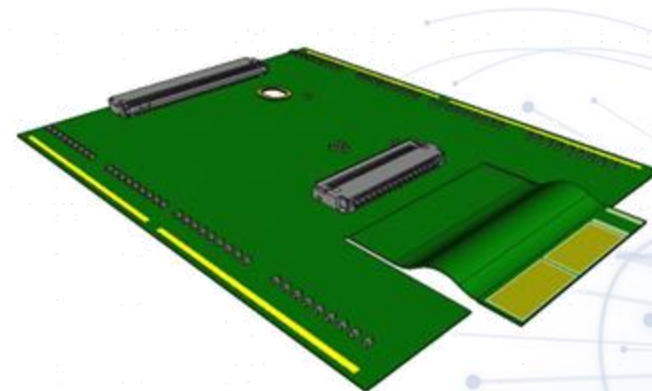
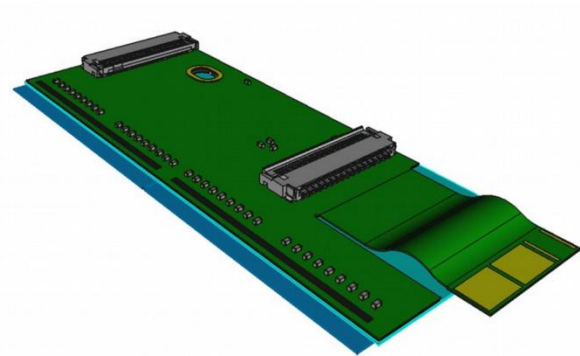

# Readout Architecture

- Communication electronics on dedicated **Portcard** (optoelectronic service board)
- A portcard hosts **3 × IpGBTs and VTRx+ links**, powered via cascaded DC-DC converters
- **Up to 6 electrical uplinks** at 1.28 Gb/s (module → IpGBT), with data formatting for rate reduction
- **1 electrical downlink** at 160 Mb/s (IpGBT → module)

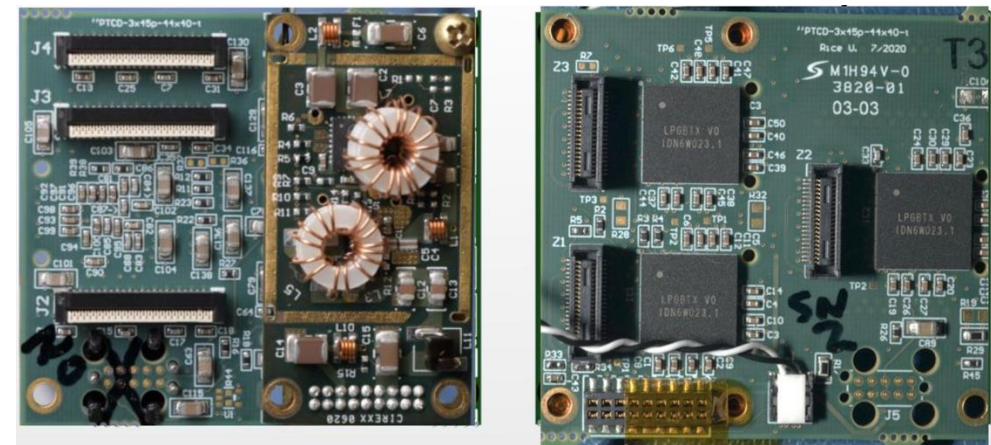
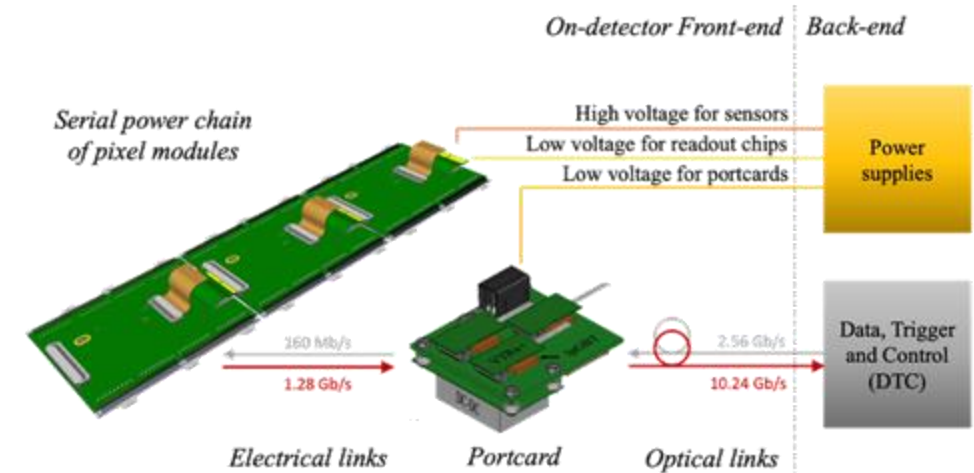

# Powering the IT

- Supplying 50 kW with minimal cable mass – **Serial Powering**
- 576 serial power chains, each with up to 12 modules in series
- Modules in series; chips inside each module powered in parallel (4 A for 1×2 modules, 8 A for 2×2 modules)
- Each chip has a **shunt-LDO** for voltage regulation at constant current
- Sensor bias follows the power chain with a single return line.

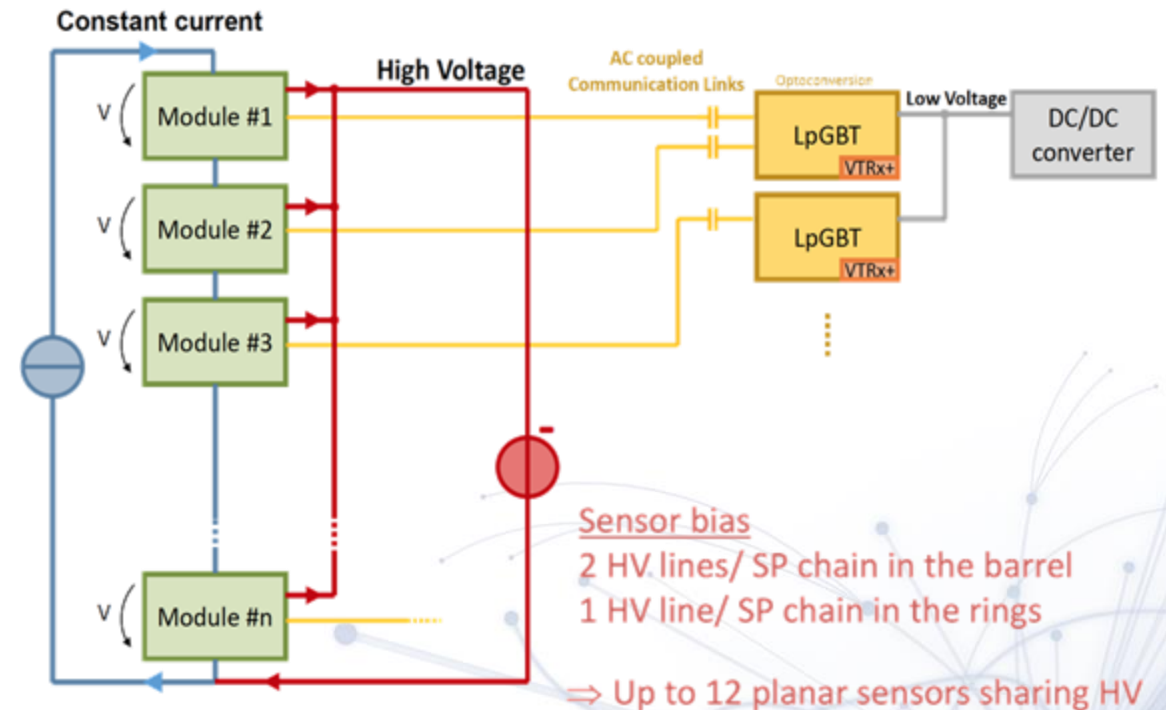

# Integration - assembly

TBPX  
manual  
assembly with  
Jigs

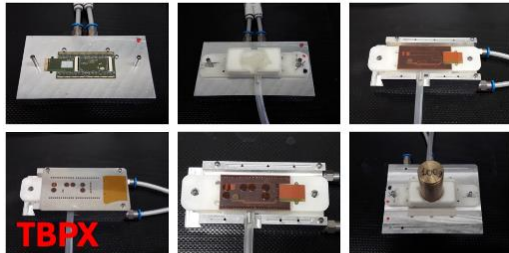

TFPX  
assembly with  
gantry

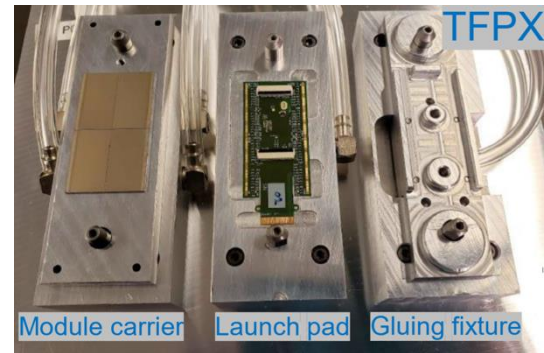

TEPX  
full robot arm



More in Mauro di Nardo's [talk](#)  
on Thursday!

# Integration – Quality Control

- IV curves testing
- Basic functionalities of the chips tested with [Ph2 ACF](#) software
- Automated QC procedure with [Panthera/Felis](#) + [Dirigent](#) + [GUI](#)

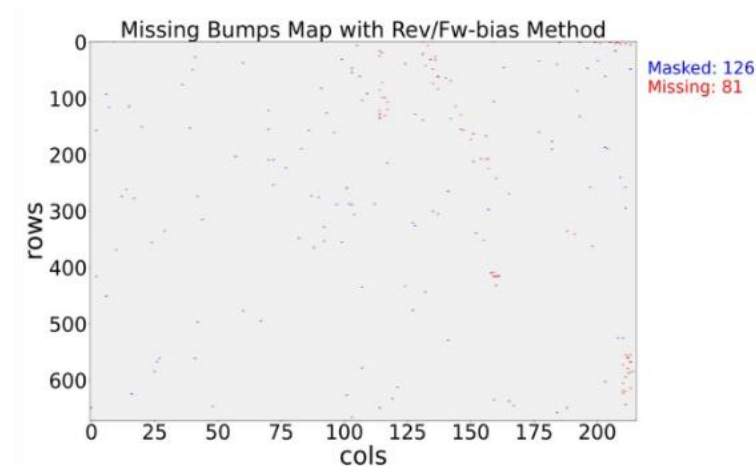
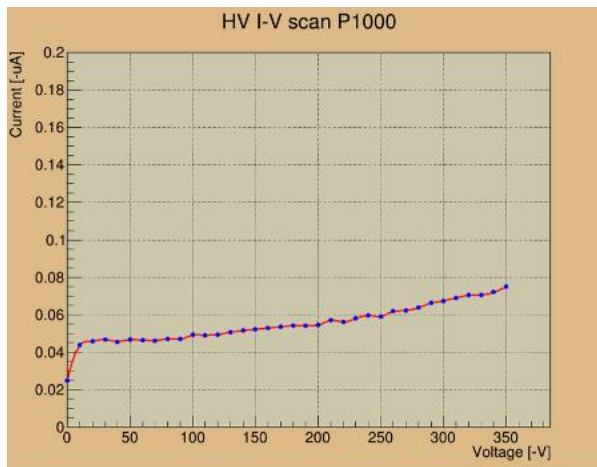

# Integration – System test

- 4 different setups with final integration structures
  - TBPX for L2 and L3/4
  - TFPX disk
  - TEPX disk
- **Thermal and mechanical** studies
- **Power distribution** tests
- **Full DAQ chain** tests

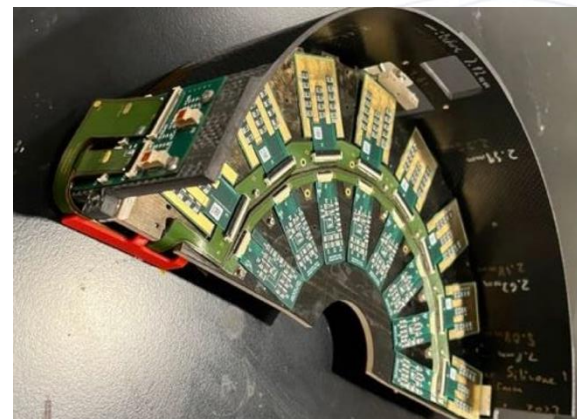
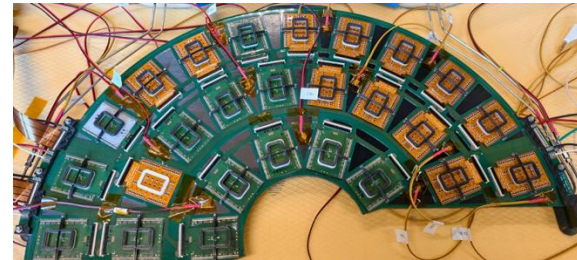
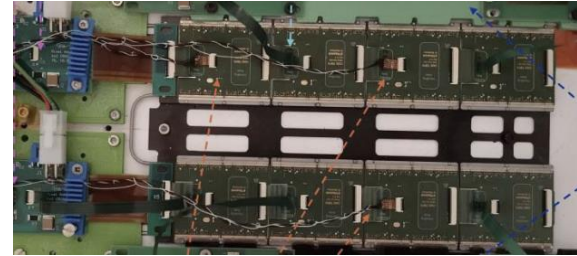
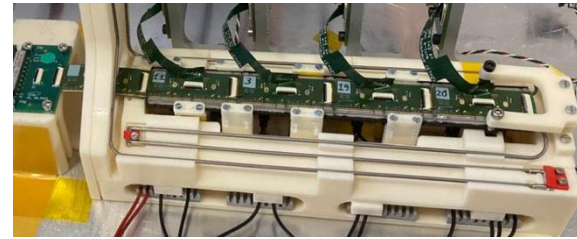

# Outer Tracker

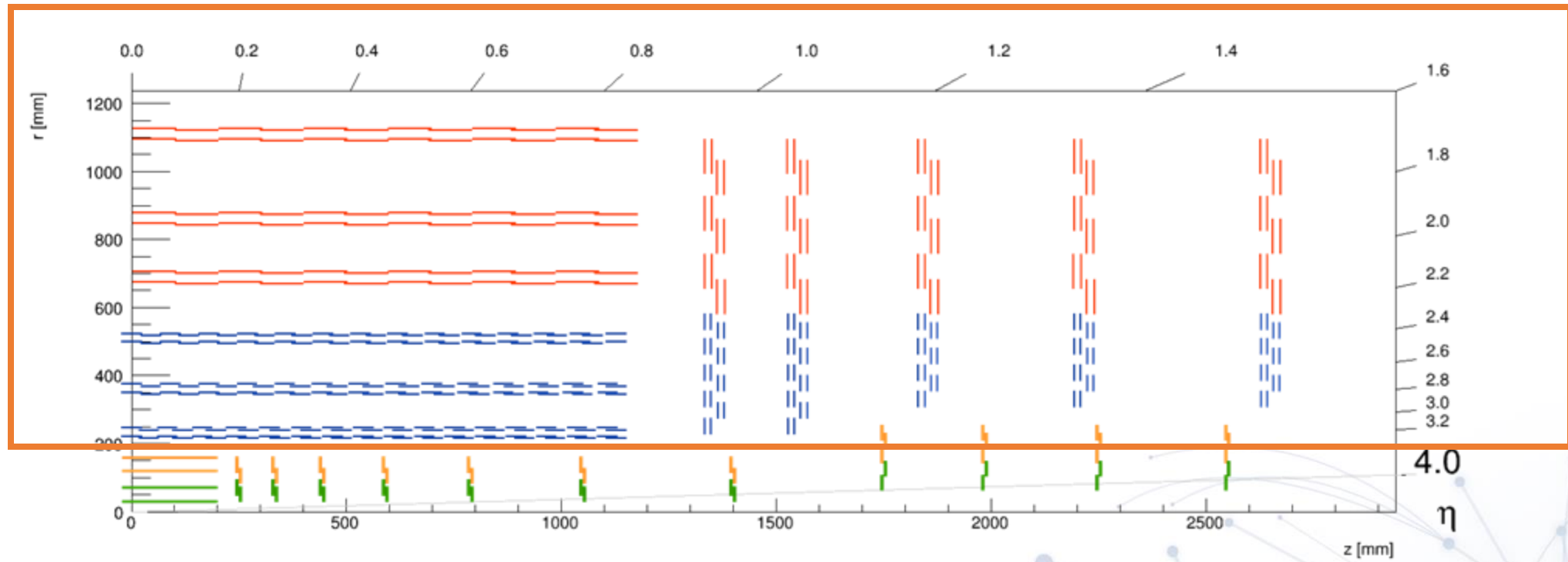

# Outer Tracker – pT modules

- $p_T$  selection at readout level in order to reduce the L1 tracking input data size

## pT modules

- Two silicon sensors with small spacing in a module
- Flex hybrid in order to get data from both sensors to one ASIC → **Select track «stubs»**
- Different sensor spacing for different detector region
- Tunable correlation windows

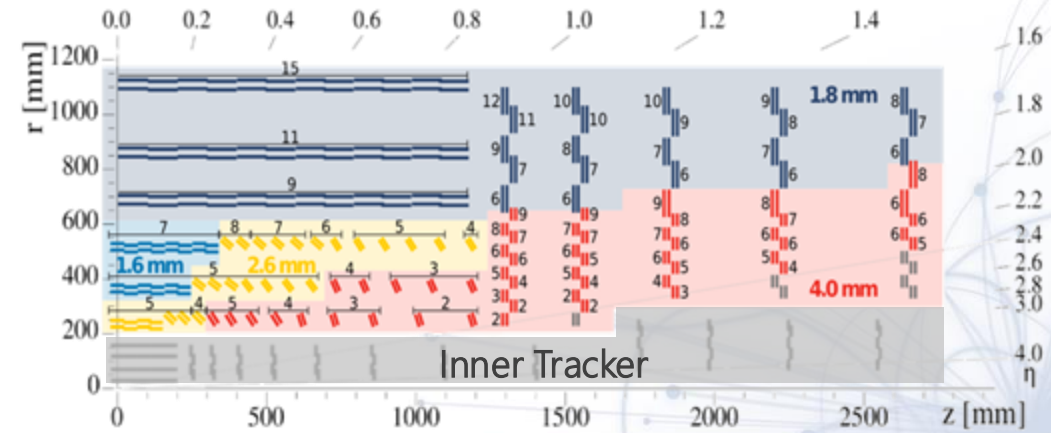
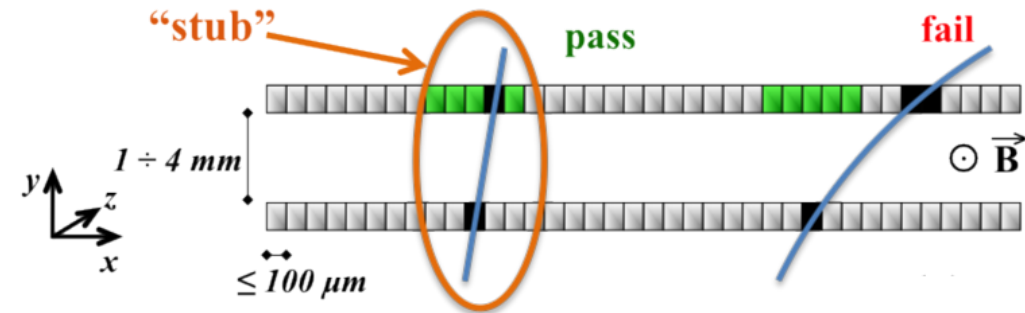

# Outer Tracker – pT modules

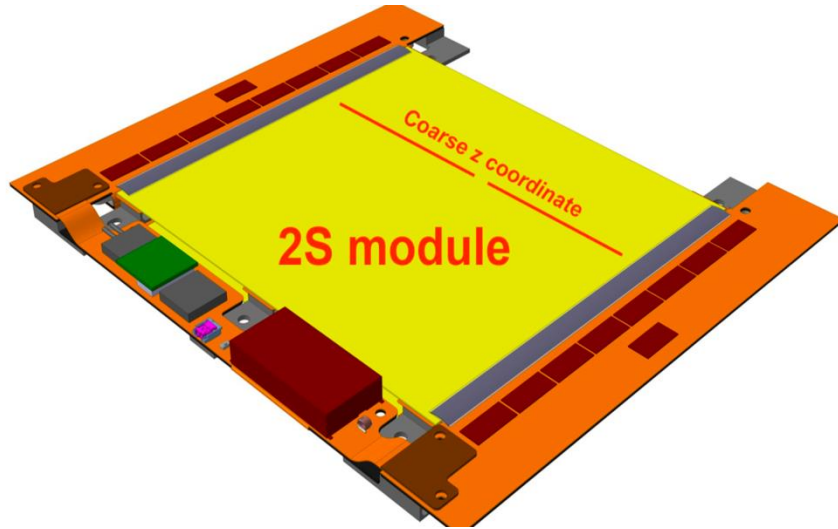

- **2S Modules**

- 2 different spacings: 1.8 & 4 mm
- 2 micro strip sensors with 5 cm x 90  $\mu\text{m}$  strips
- Sensor dimension: 10cm x 10 cm
  - Two columns of 1016 strips

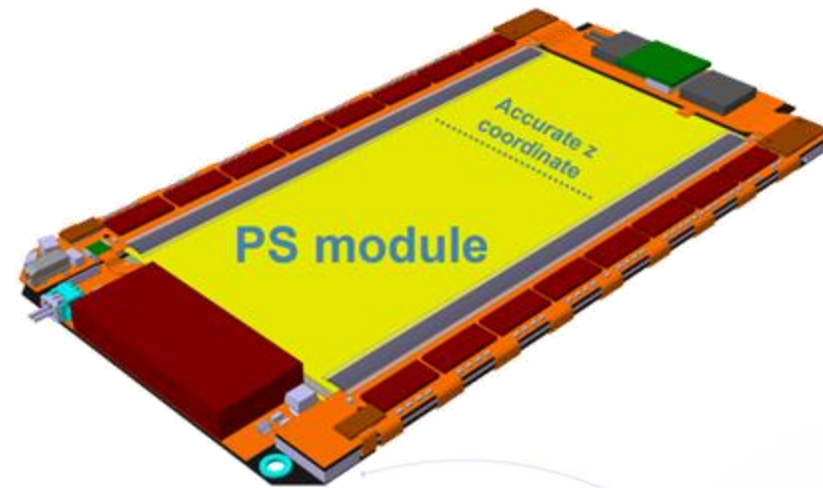

- **PS Modules**

- 3 different spacing : 1.6mm & 2.6mm & 4mm
- Strip sensor (2.5cm x 100 $\mu\text{m}$  strips) + Macro Pixel sensor (1.5 mm x 100  $\mu\text{m}$  pixels)
- Sensor dimension 5cm x 10 cm (two column of 960 strips + 32x960 pixels)

# Outer Tracker – pT modules

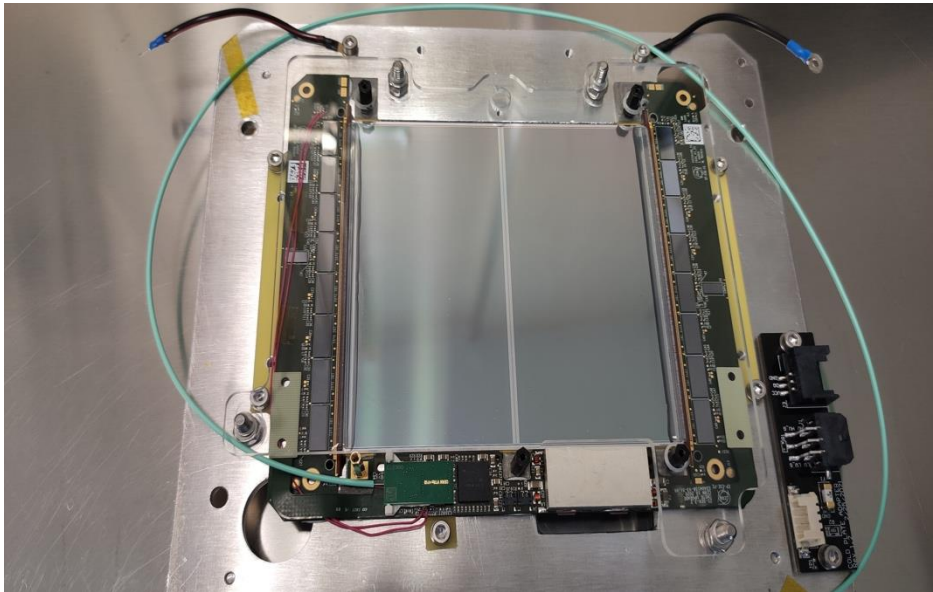

- **2S Modules**

- 2 different spacings: 1.8 & 4 mm
- 2 micro strip sensors with 5 cm x 90  $\mu$ m strips
- Sensor dimension: 10cm x 10 cm
  - Two columns of 1016 strips

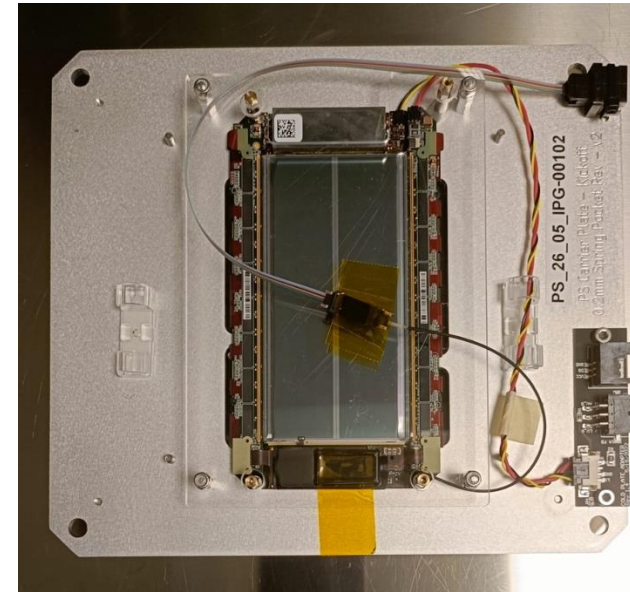

- **PS Modules**

- 3 different spacing : 1.6mm & 2.6mm & 4mm
- Strip sensor (2.5cm x 100 $\mu$ m strips) + Macro Pixel sensor (1.5 mm x 100  $\mu$ m pixels)
- Sensor dimension 5cm x 10 cm (two column of 960 strips + 32x960 pixels)

# Latest Test Beam with PS modules

- 2024 Fermilab TB: PS-module with 1.6 mm spacing was tested **before and after irradiation** at a fluence slightly higher than expected for the HL-LHC end of life scenario. Comparable performance have been found before and after irradiation

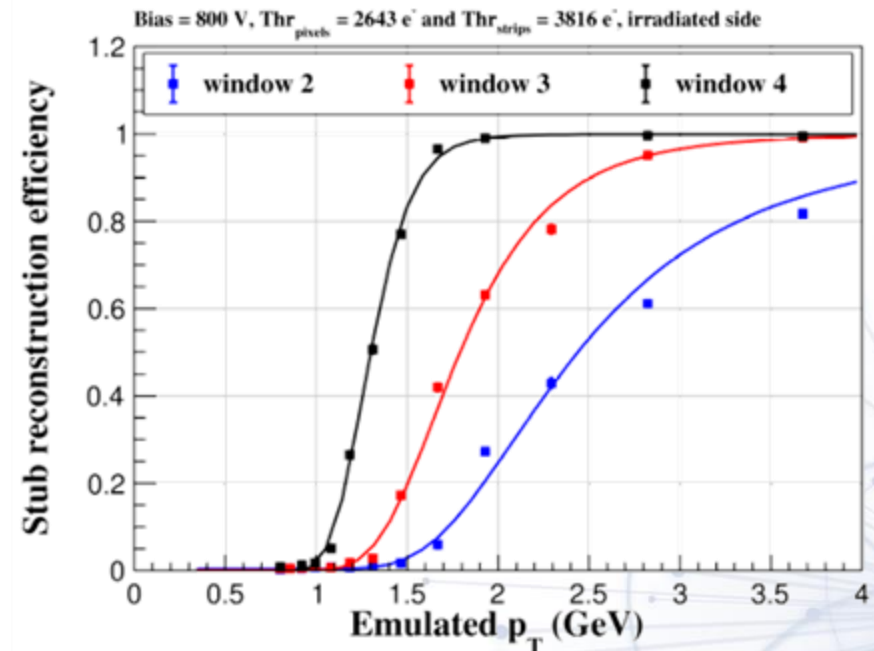
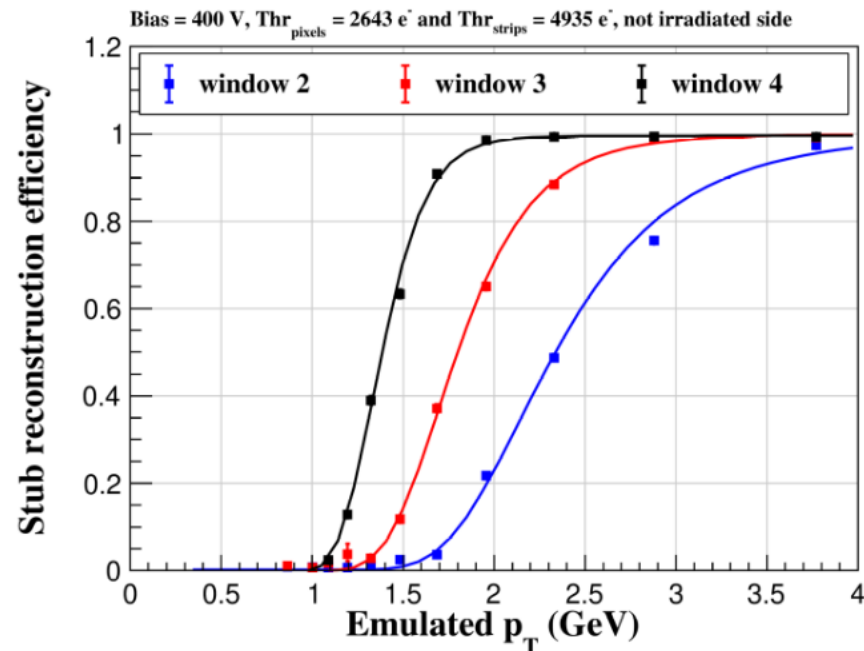

Nicolò Salimbeni, [Tredi 2025](#)

# Outer Tracker Final DAQ Chain

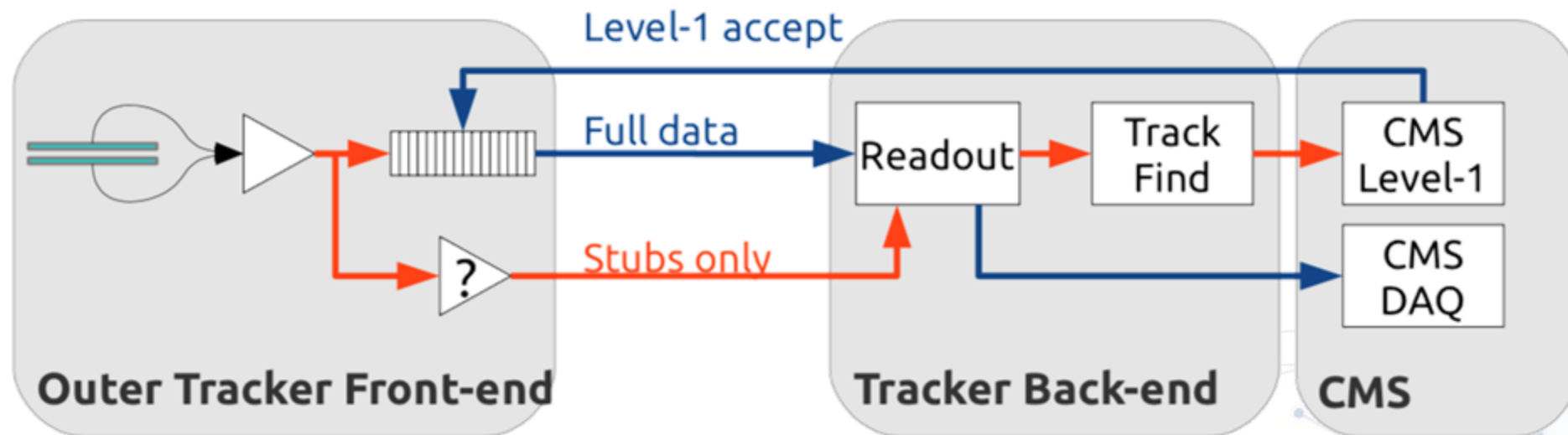

# Outer Tracker Final DAQ Chain

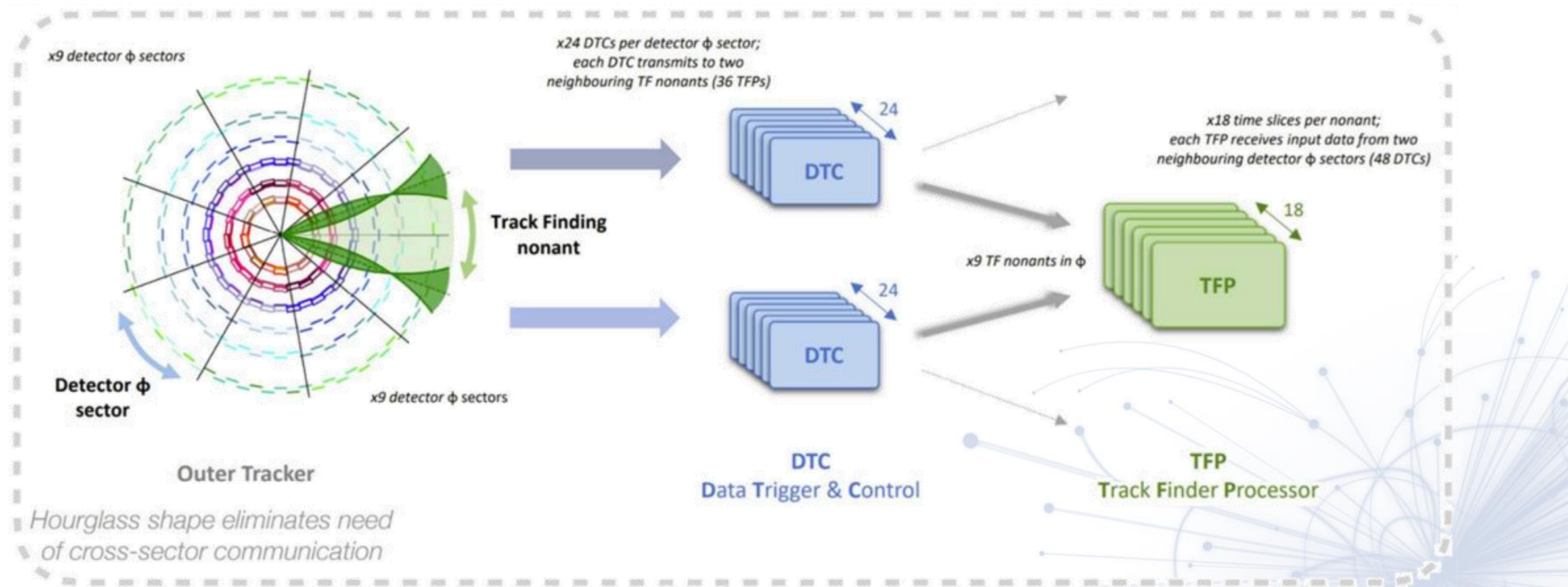

# ShepHerd's RunControl framework

Phase-2 tracker online software will be based on the **ShepHerd's RunControl framework** (jointly developed by L1T & tracker). High level architecture:

- **Run Control** – Global layer
  - 1 instance responsible for the whole tracker
  - Web GUI for people + network API for CMS top-level run control application
- **Shep** – Off-board supervisor
  - 1 instance per subsystem (e.g. TF, OT, IT)
  - Web GUI for people + network API for RUNControl
- **Herd** – On board controller
  - 1 instance per board
  - Single common .exe with board/subsys agnostic network api; loads board/subsys specific plugin

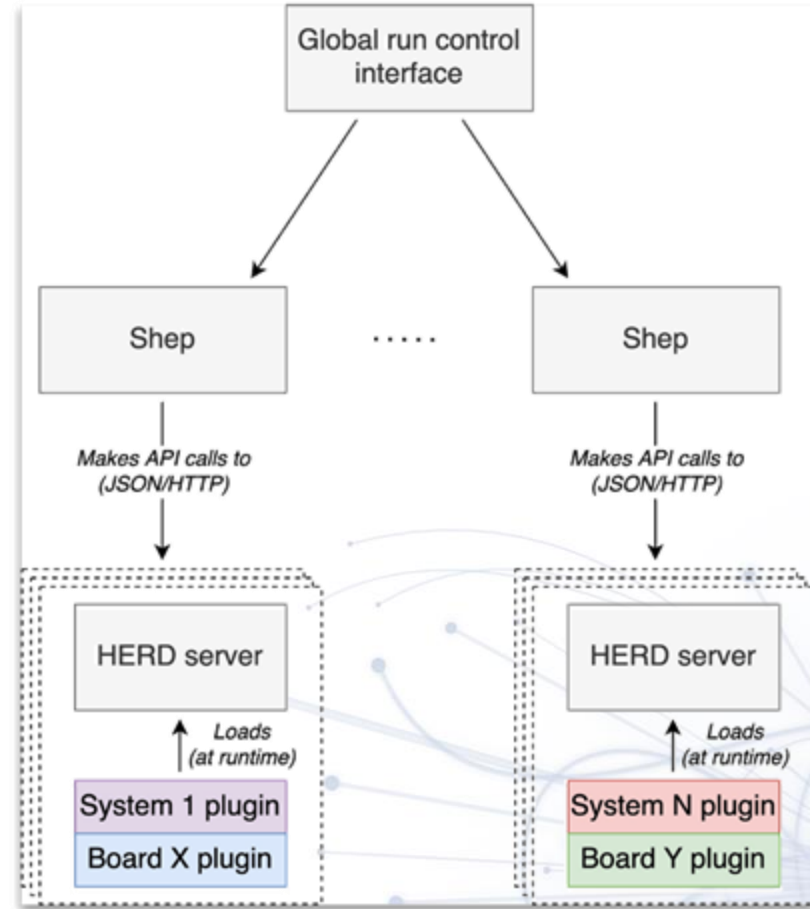

# DTC-Plugin: tk-fe-daq



- Library providing control and calibrations for OT and IT modules on DTC
- Extra attention to deployability, testing, possibility to complete computation on the System On Module for the DTC



## Temperature and Current Monitoring

Continuous monitoring and storage in database, with communication to centralDaq



## Setting Modules in Data-Taking mode

Ability to configure the modules to correctly output data (stable setup after alignment and calibrations)



## Single Event Upset (SEU) Detection and Correction

Once spotted SEUs, reconfiguration is needed



## Module Calibration Routines

Ability to run calibration routines to check the goodness of data, account for possible shifts in calibration and degradation of the modules

# Integration – Assembly

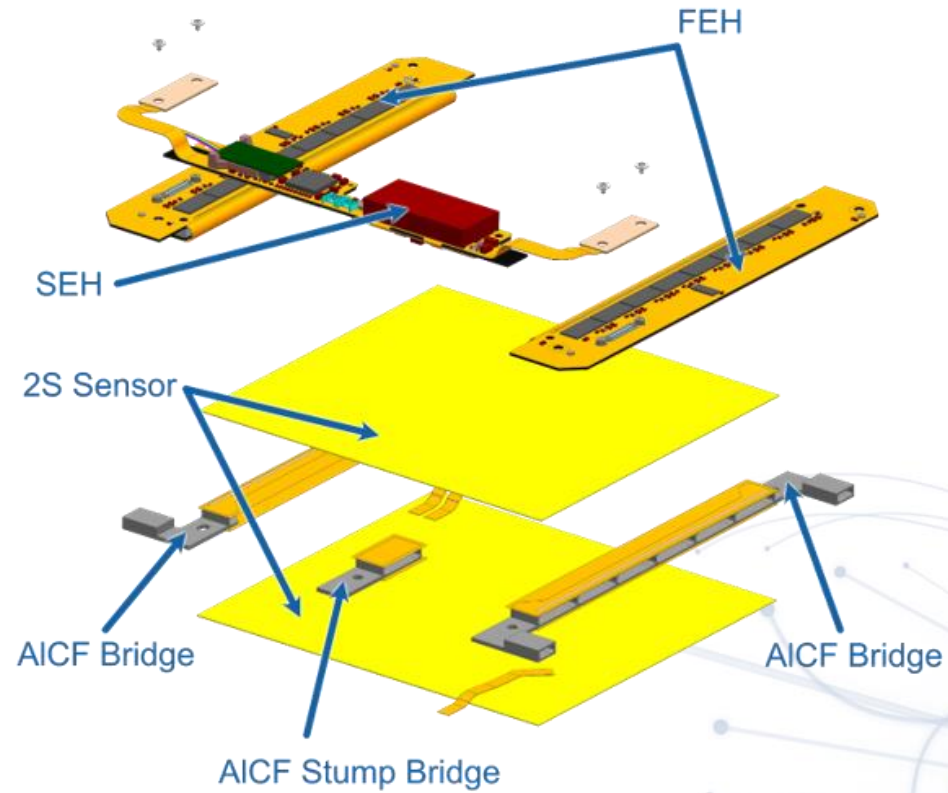
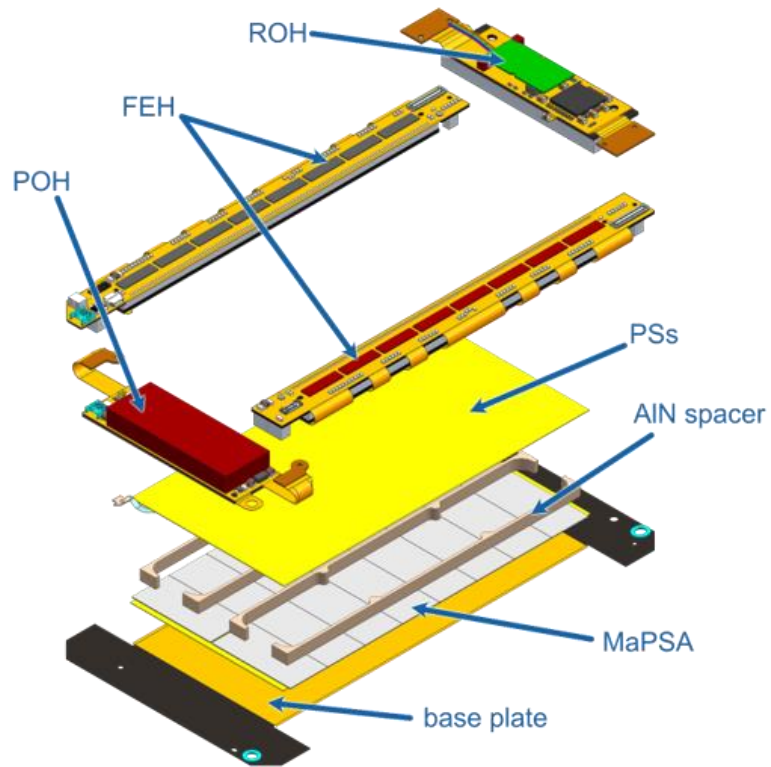

More in Dimitra Andreou's [talk](#) on Thursday!

# Integration – QC

- IV characterization + basic chips functionalities + **noise measurements**
- 48 **thermal cycles** from 20°C to –35°C with tests in between
- Analysis of the results through [Ph2\\_ACE](#), [Gipht](#) and [POTATO](#) software

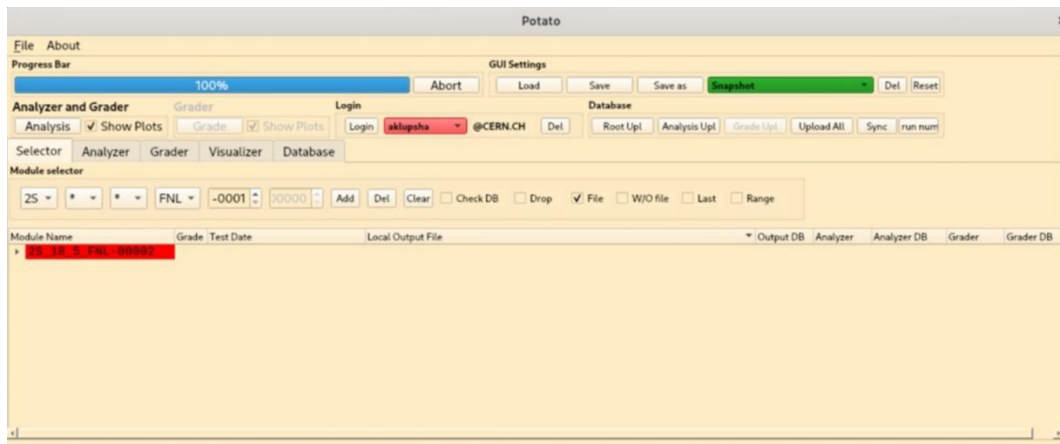

# Integration – System test

- Integration centers assemble modules in planks, rings, dees, ladders
- TEDD Dee assembly test: 13 2S and PS modules
  - PS modules affected by prototype-specific known issue
  - Noise on modules: **no significant increase after mounting on DEE**

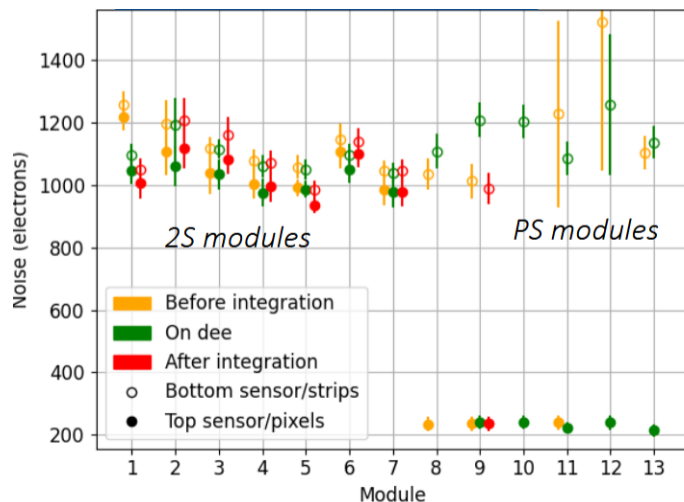

[Lea Stockmeier, TIPP, 2023](#)

# Integration – System test

- Integration centers assemble modules in planks, rings, dees, ladders
- 2S ladders prototype, more being built right now
  - Prototype Phase-2 tracker PSU
  - **No significant noise increase on the ladder**

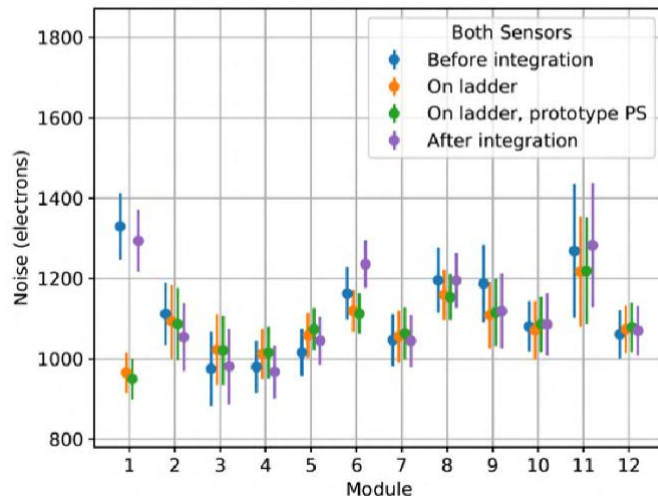

[Lea Stockmeier, TIPP, 2023](#)

# Cosmic Rack

- Up to 12 2S ladders
- Scintillator+ PMT → **Trigger + position of cosmic rays**
- **Assemble and integrate the full final DAQ chain,** with track finding and offline data processing

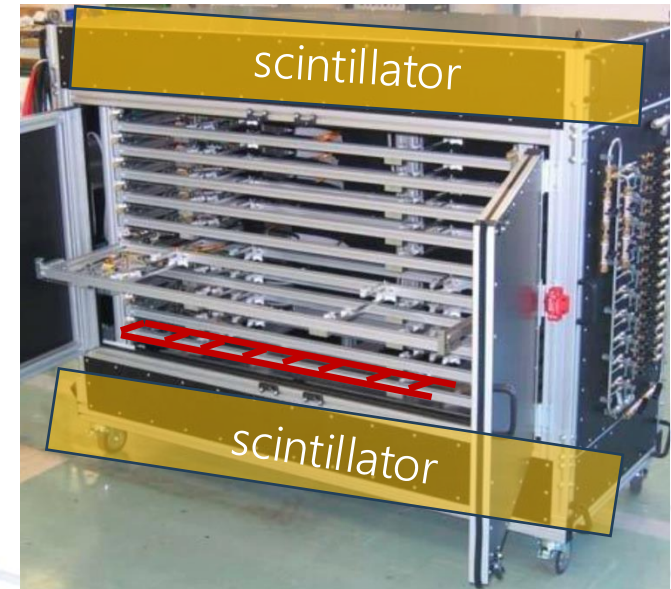
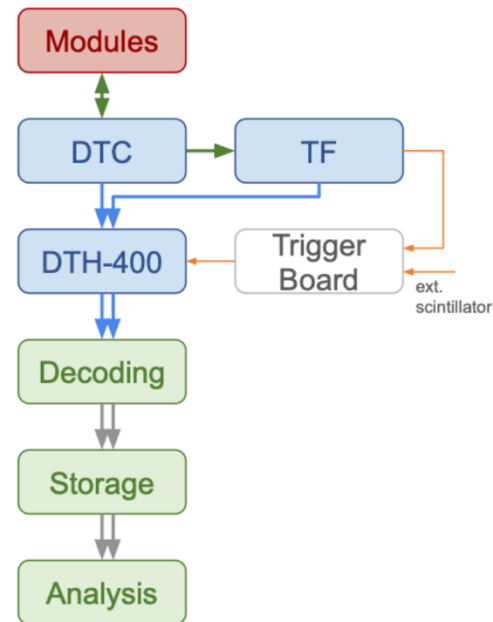

# Integration Testing



Reception test of individual ladder/ring

- Basic communication with DTC (ShepHerd + tk-fe-daq)
- Powering
- Integrity
- Variation in noise due to integration



Mechanical integration

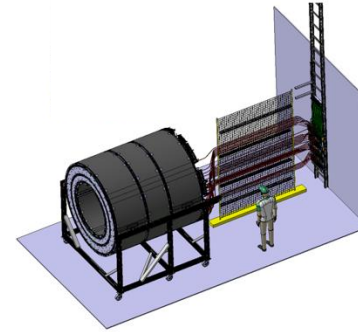

Pressure & leak tests → Connect to services & CO<sub>2</sub>

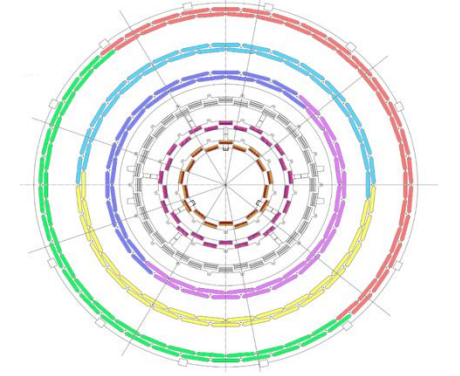

Cooling segment test:  
~ 500 modules on 1 CO<sub>2</sub> manifold

- Backend system scaling: **first time with > 1 DTC worth of modules!**

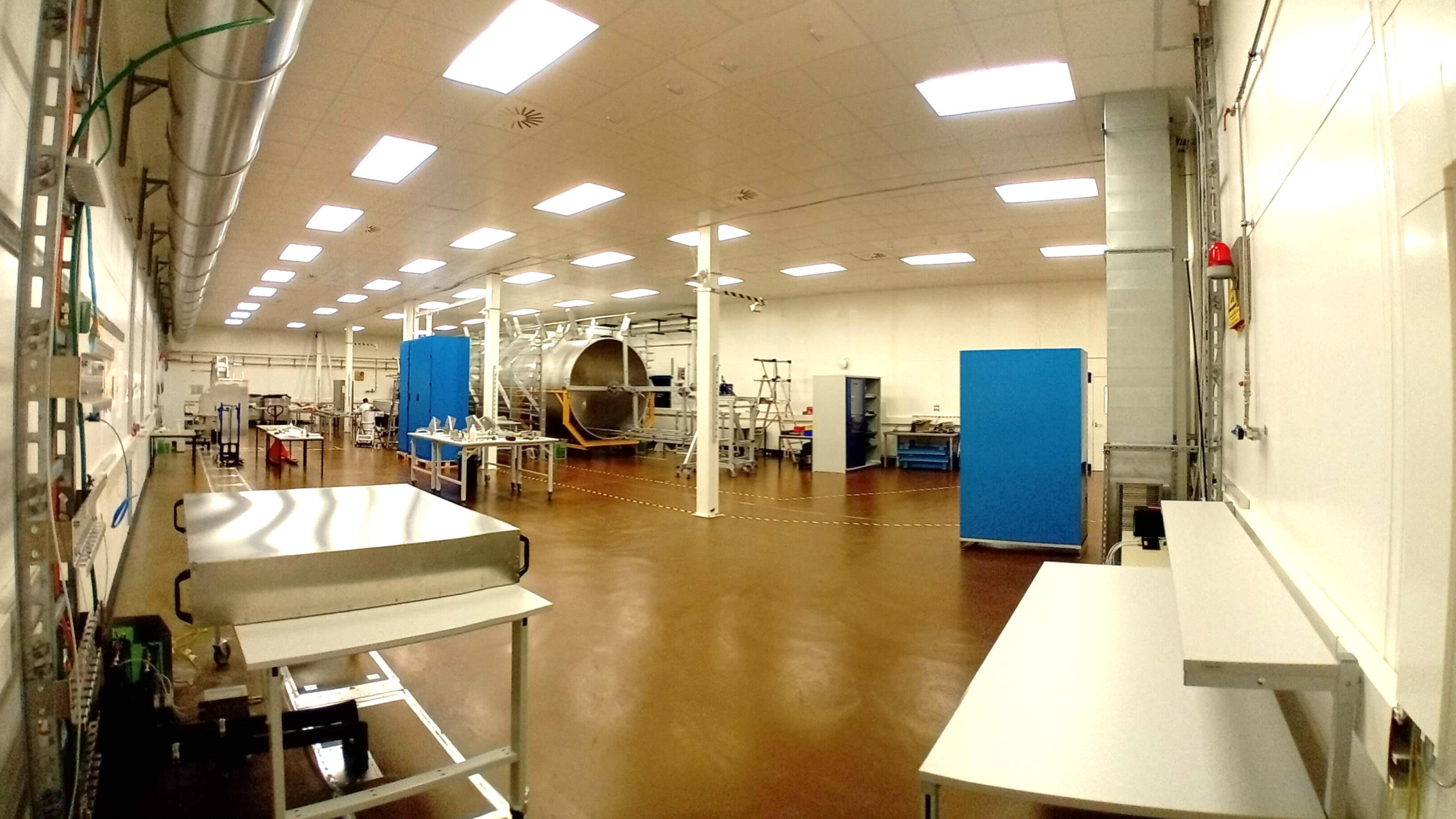

# Timeline

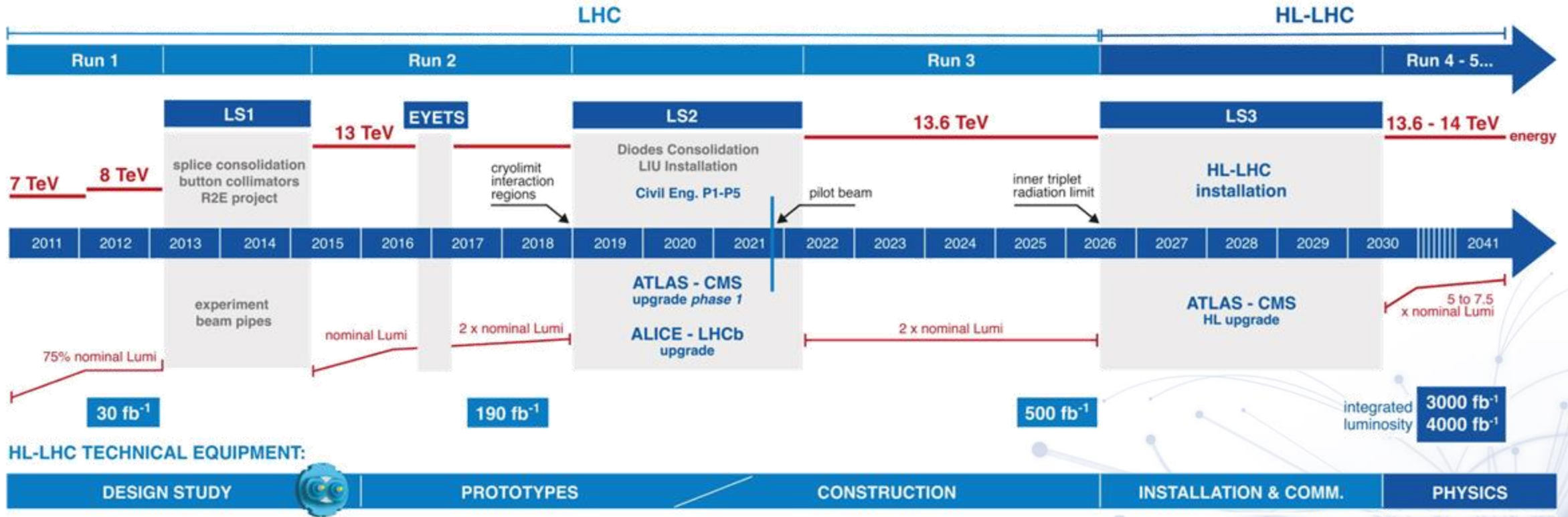

# Conclusions

- **CMS Tracker will be fully replaced for High Luminosity LHC:** Outer Tracker contribution to L1 trigger and performance improvement with 200 PU events
- **Production started:** for both Inner and Outer Tracker, QA & QC developed and in good shape to support full production
- **Support infrastructure in place:** mechanical, powering, and cooling systems are under active test and evaluation
- **Integration for System Test:** with module production kicking on, first assembled mechanical structure are being built and tested
- **DAQ development on final boards:** quick development to support and validate the system test integration