

ePIC's LFHCAL

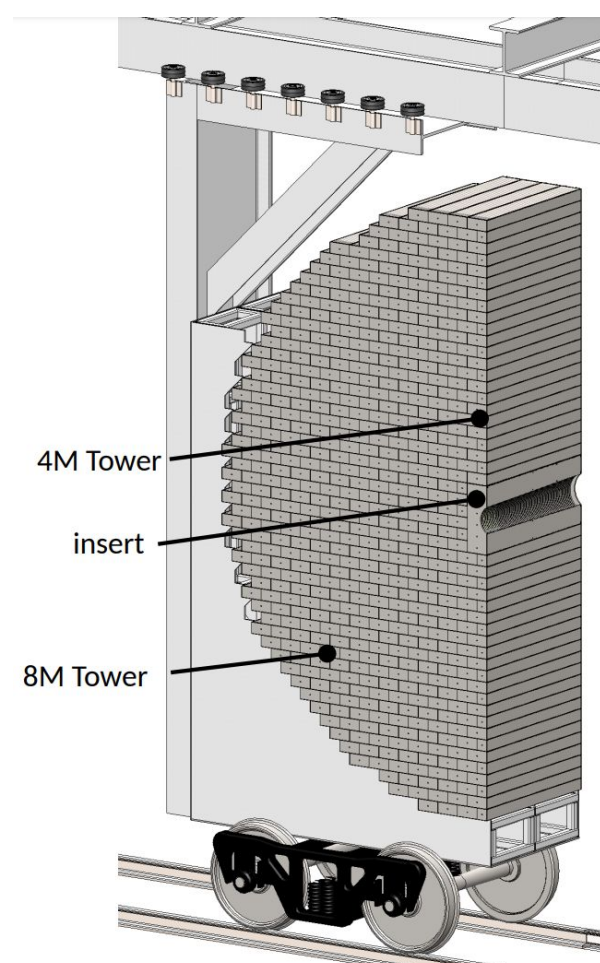

- 1100 "8M" modules
- Absorber structure electron beam welded
- Goal is to build one full test "8M" module for test beam at CERN starting 28th of August.
 - Need to construct and quality control 65+10 scintillator-SiPM layers.

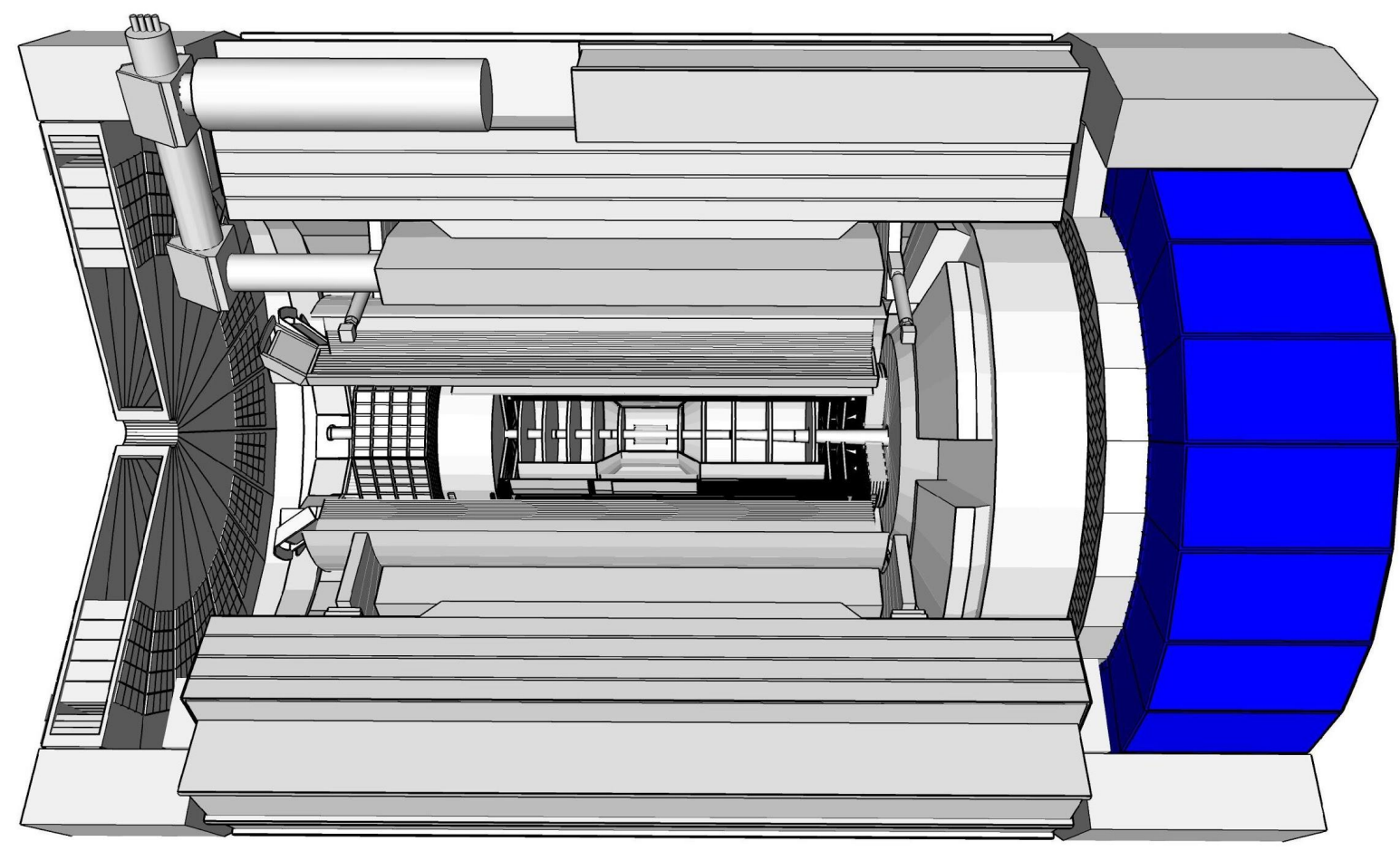
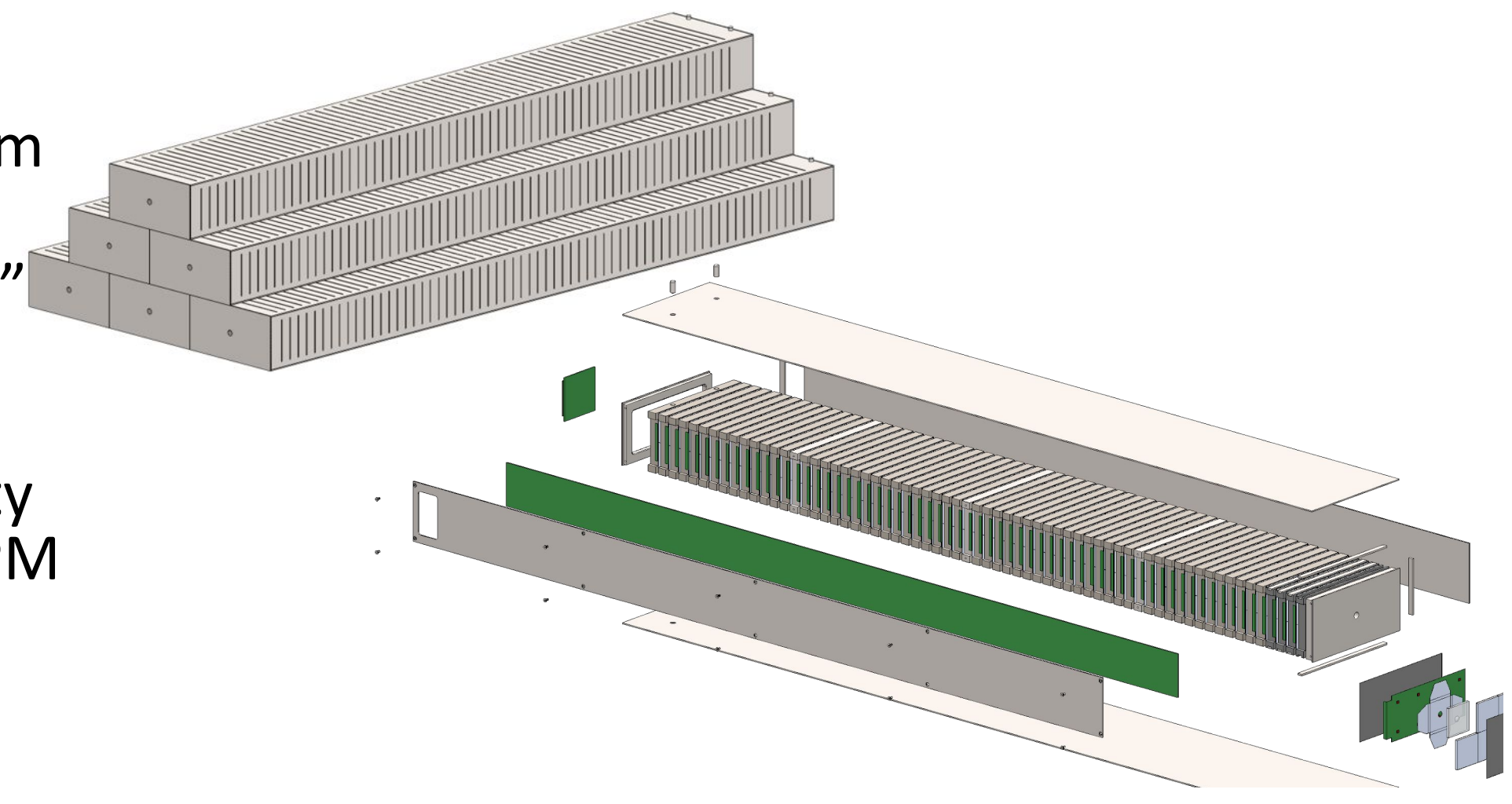

SiPM Board Testing

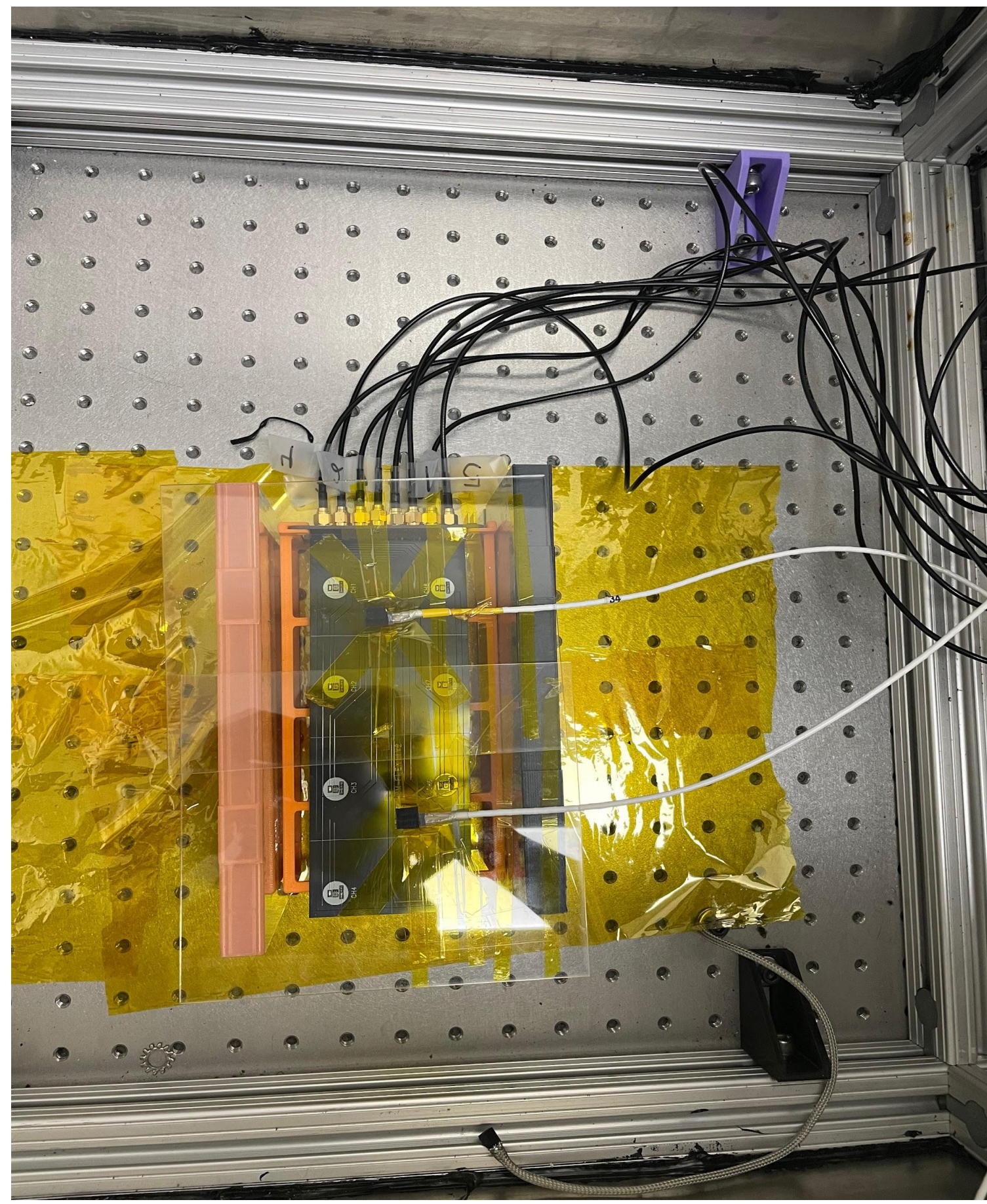

- Need to qualify and calibrate each sensor board.
 - Each board has 8 SiPMs connected to a single high density connector.
- Test setup in a dark box environment:
 - with a CAEN front-end read-out (FERS) units reading out all 8 SiPMs per board
 - with 2 LEDs + Waveform Generator
- The qualification with short flashes of LED are:
 - Ensuring proper functioning of the SiPMs.
 - Measuring the ADC-to-photon conversion ratio
 - Verifying the seamless integration and operation of the FERS units.
- Tested 78 SiPM boards (624 Channels).
 - All tested boards qualified for test beam use.

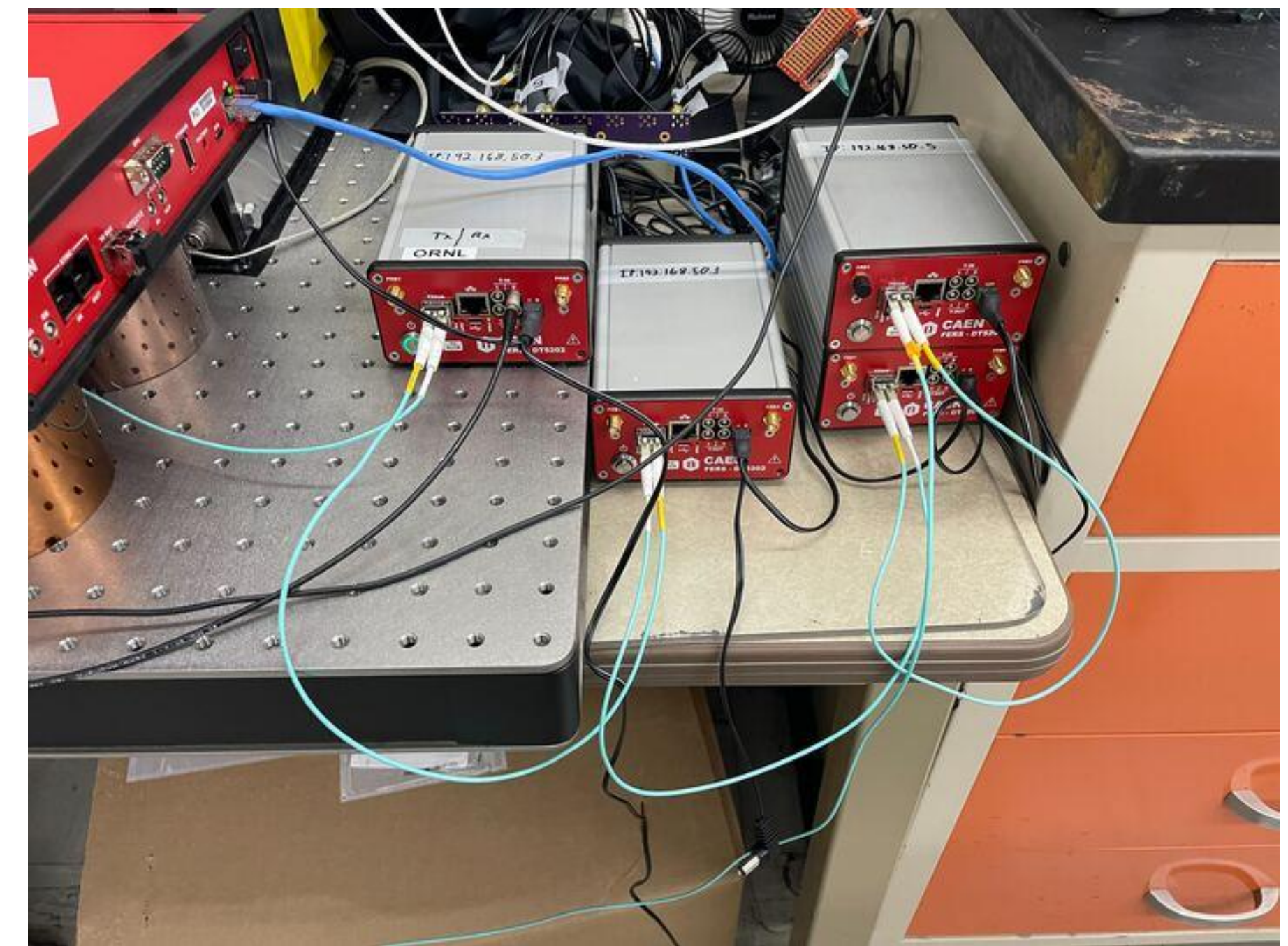

Single Photon Spectra (SPS) Fittings

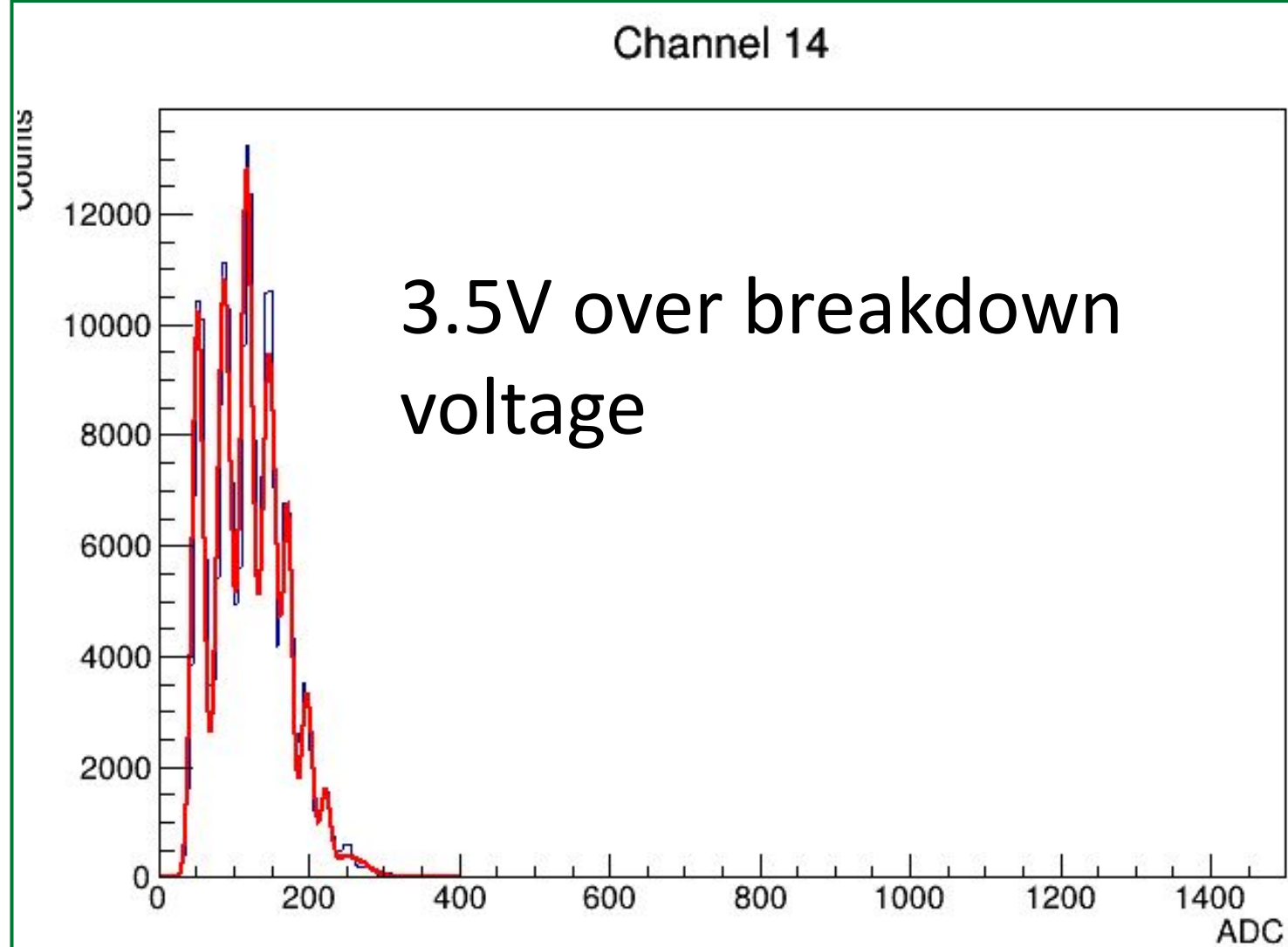

- Utilized PyRoot to interpret and manipulate photon spectra for chip characterizations.
- Investigating starting parameters greatly impact the quality of fittings for the various tiles.
- Each peak corresponds to a exact number of photons measured.
 - When fitting we can quantify a ADC-to-photon ratio

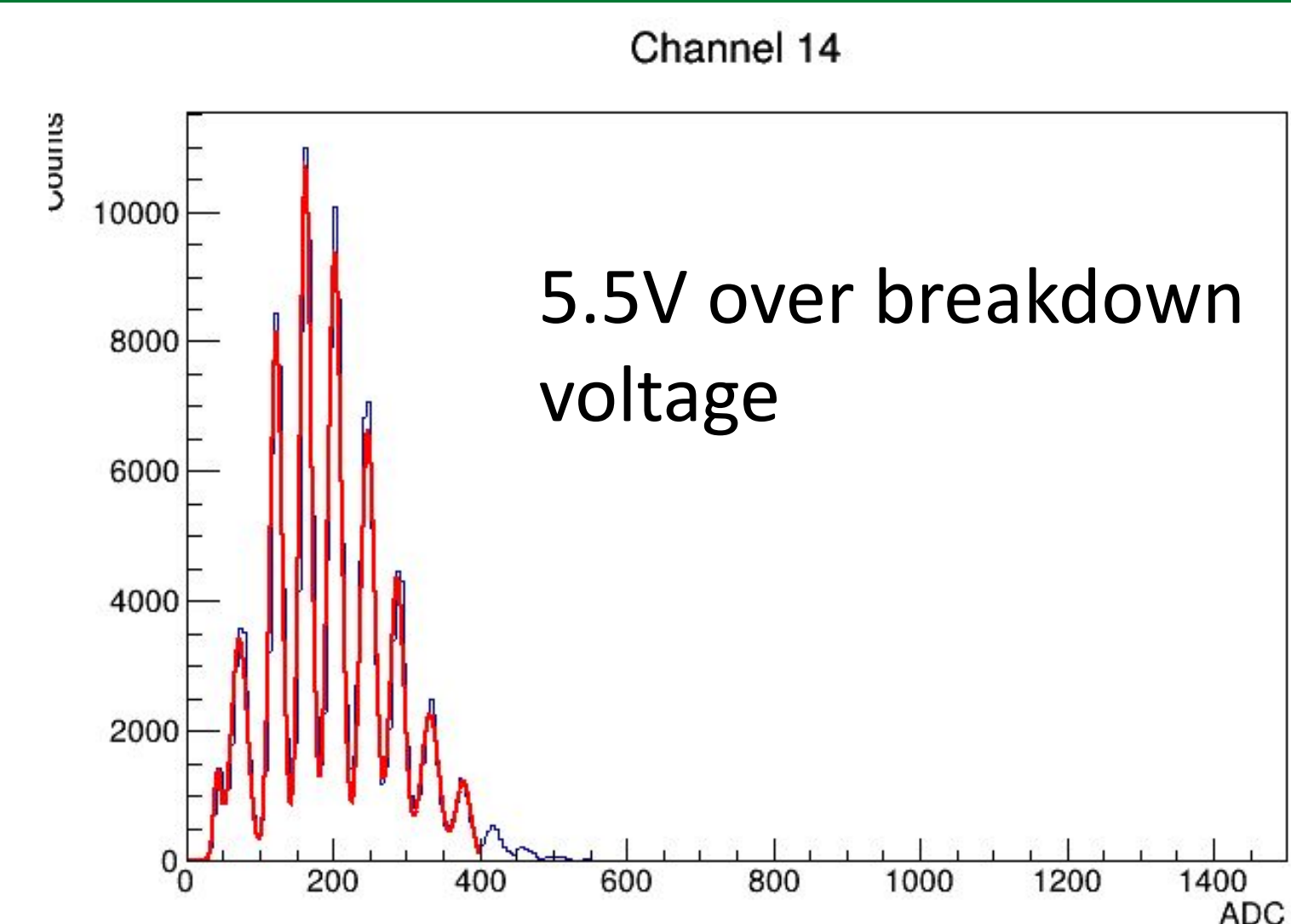

Large Scale System Test

- For the test beam, 520 SiPMs will be in use at onces.
- One FERS unit can interpret 64 channels -> We need to operate up-to 9 units synchronously.
- Constructed and operated with 4 units in a test bench setup.
 - utilized CAEN Data Concentrator
 - Tested trigger distribution
- Tested different order of daisy chaining the FERS units
 - Units in a chain
 - Standalone units
- Ready for test beam use.

