

Development of Near Quantum Limited Kinetic Inductance Traveling-Wave Parametric Amplifiers Using Four-Wave Mixing

Farzad Faramarzi¹, Sasha Sypkens¹, Mary Kriedel¹, Ryan Stephenson^{1,2}, Byeong H.Eom¹, Henry Leduc¹, Peter Day¹

¹ *Jet Propulsion Laboratory, California Institute of Technology, CA, USA*

² *Division of Physics, Mathematics and Astronomy, California Institute of Technology, CA, USA*

Farzad Faramarzi | JPL

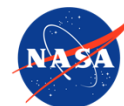

Jet Propulsion Laboratory
California Institute of Technology

Parametric Amplifiers

- Parameter of the system is varied with a strong “pump”
- $\delta L \sim I_{Pump}^2$ Nonlinearity in the resonant circuit
- *Nonlinearity* transfers power from pump to signal
- Purely reactive nonlinearity
 - Need not add noise beyond the QM limit
- E.g., Josephson parametric amplifiers
 - Narrow band

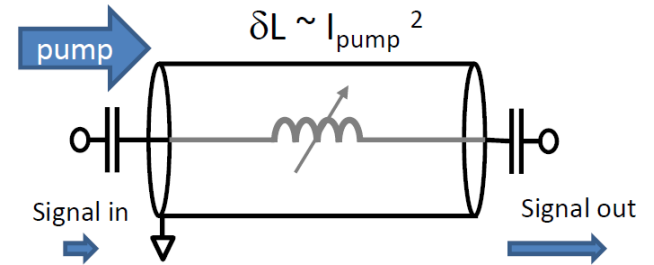
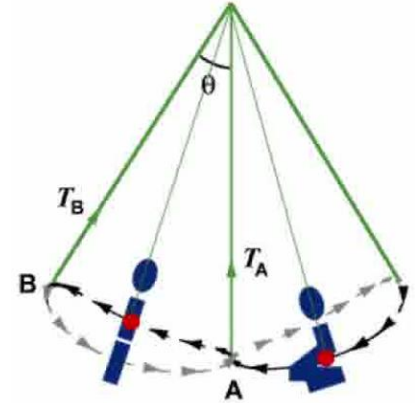

Kinetic Inductance – Traveling Wave Parametric Amplifier

KI Nonlinearity of a Microstrip Line

- Distributed geometry, e.g., non-linear transmission line
- Energy transfer along the length of the transmission line
- Near ideal nonlinearity $L_K(I) = L_K(0) \left(1 + \frac{I^2}{I_*^2} + \dots \right)$
- Analogous to Kerr nonlinearity in optics (intensity dependent index n)
 - Supports 4-wave mixing (4WM) & other nonlinear processes

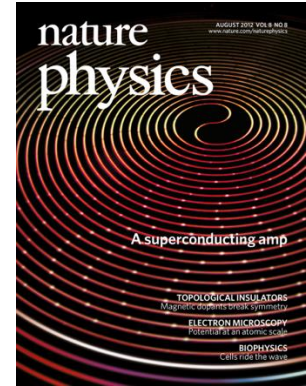
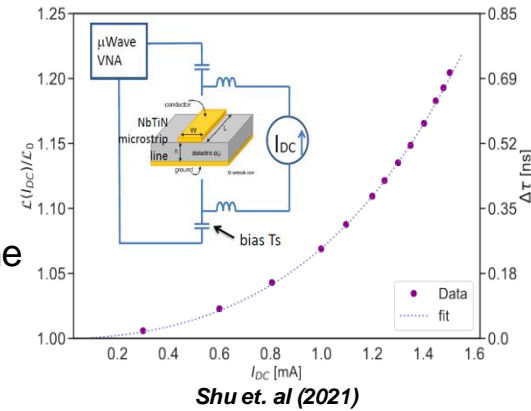

Invented by Peter Day et al.

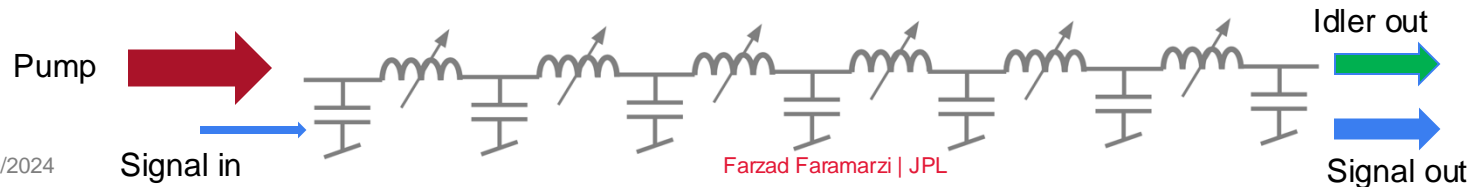

KI-TWPA

➤ Advantages over AI-JJ

- High frequency, high temp operation
- High dynamic range
- Relatively easier to fab
- Resilient to Magnetic Fields

➤ Microstrip KI-TWPAs

- Microstrip geometry
- Capacitive stubs
- Dispersion engineering

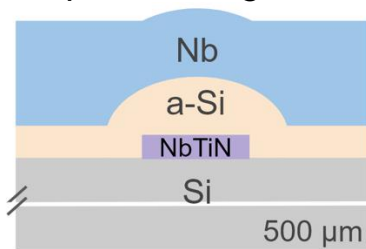

Fabrication stack

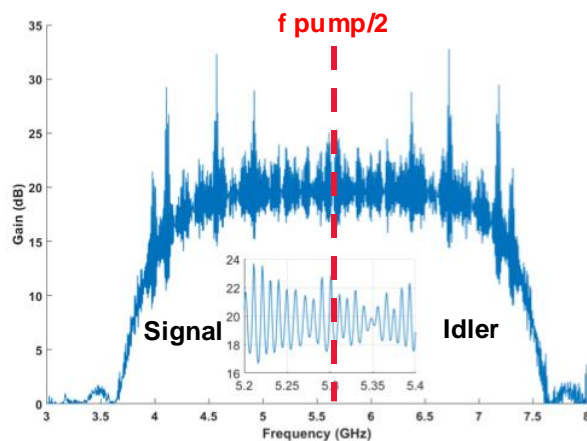
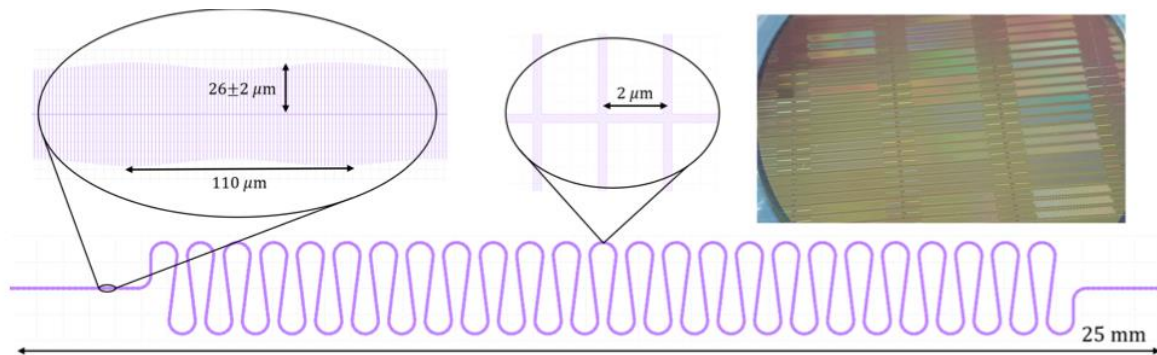

Measured gain of a 3WM KI-TWPA.

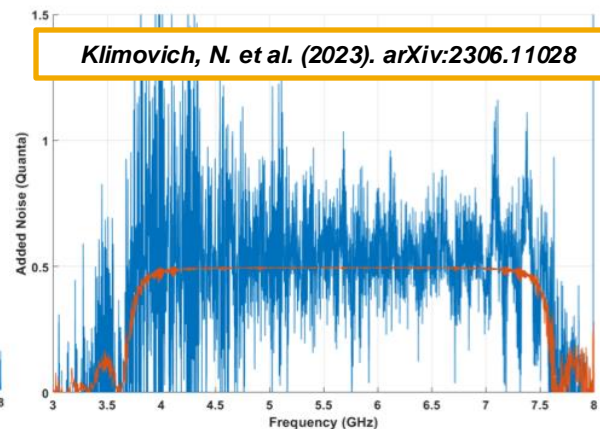

Measured added noise of the 4WM KI-TWPA.

Four-Wave Mixing Devices

4 - 8 GHz TWPA for Detector Readout

- Cover the 4 – 8 GHz range (NbTiN)
- **Separation of bands**, no contamination from idler
- Diplexers to manage pump and idler tone
- Tunable signal band gain and **dual-band operation**

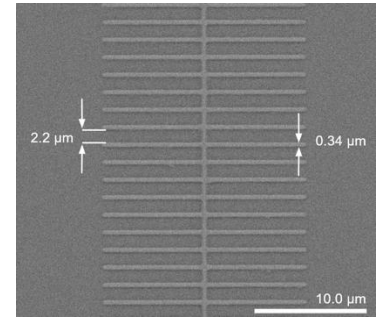

SEM image of the transmission line.

Faramarzi, F. et al., *APL Quantum* 1, 036107 (2024)

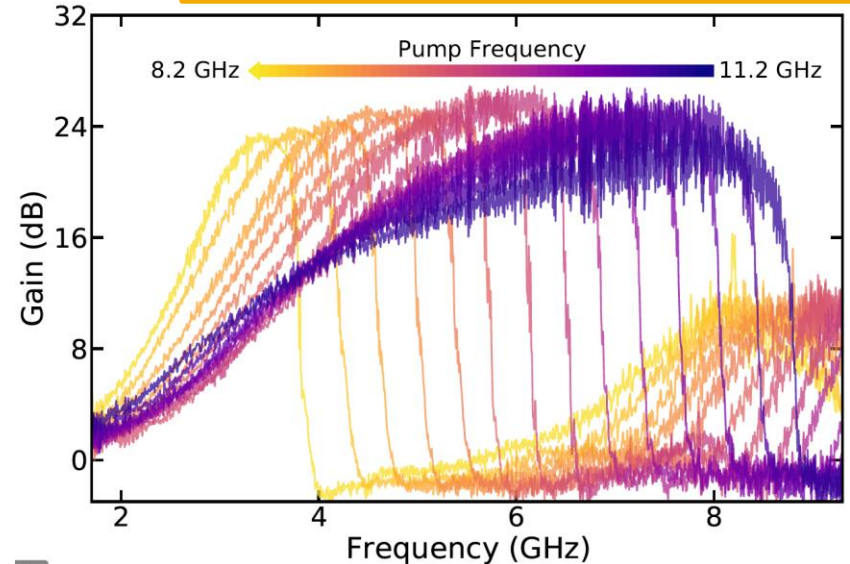
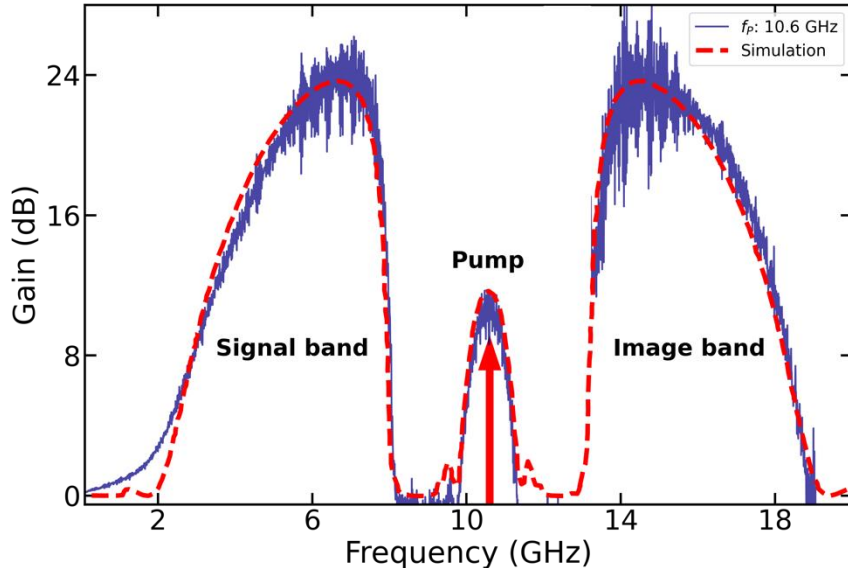

4 - 8 GHz 4WM TWPA Noise Performance

- Y-factor Method
- Near Quantum Limited performance
- High Dynamic Range (P1dB = -58 dBm @ 15 dB gain)
- Pump power ~ 10 μ W

Faramarzi, F. et al., APL Quantum 1, 036107 (2024)

$$T \ll hf_{idler}/k_B$$

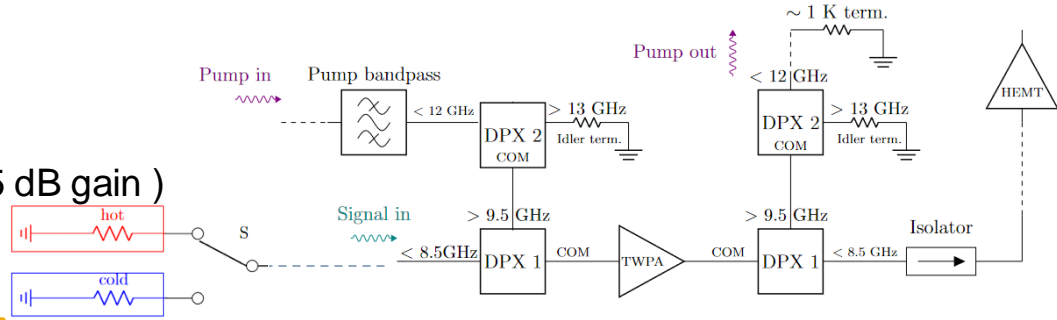

Y-factor noise setup.

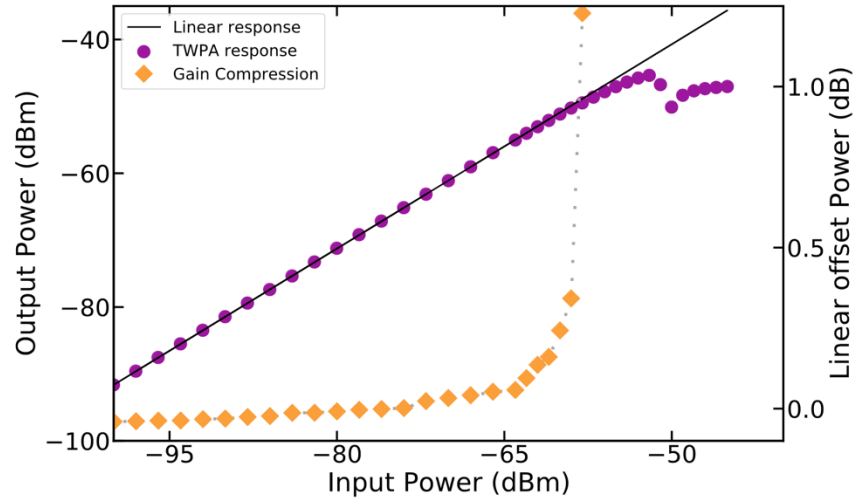
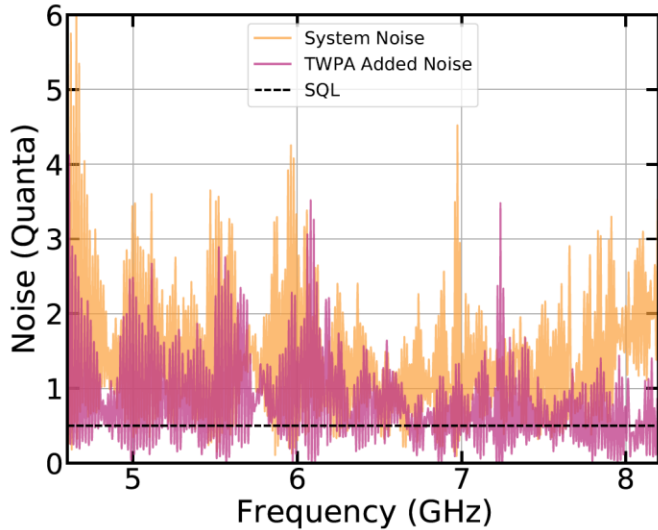

Preliminary Magnetic-Field Dependence

- collaboration with Andolab at University of Cologne, Germany
- S21 and gain measurements vs B_{\parallel} and B_{\perp} , pump settings optimized at each field

- Ultimately limited by thick Nb ground plane ($B_c=1.5$ T)
- SNR improvement can improve at intermediate B_{\parallel} but not for B_{\perp} - B_{\perp} also shows stronger hysteresis
- ~10x better field compatibility than Josephson TWPA cf. Janssen et al. PR. Appl. 22, 054018 (2024)

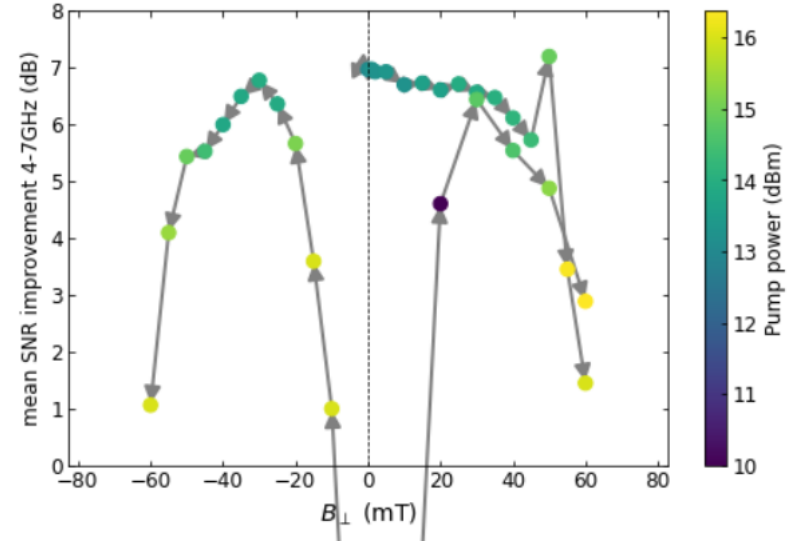
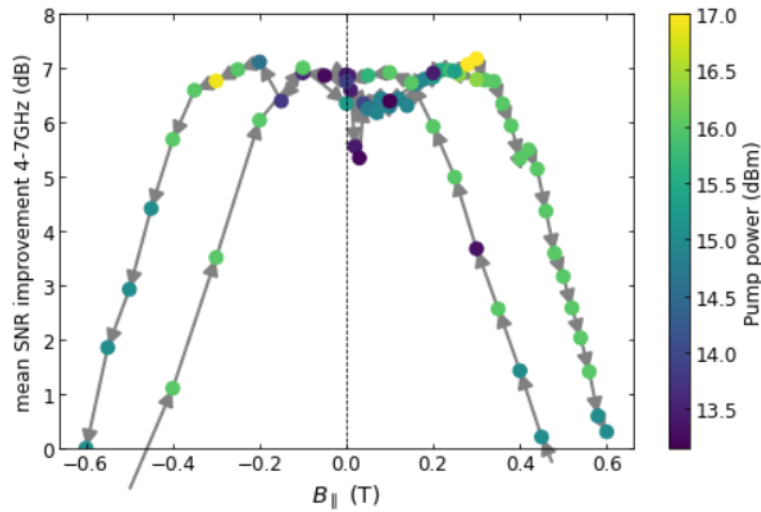

Janssen et al., in prep & @ APS March Meeting (2025)

Preliminary data on High-temperature operation

- measured in Cologne (fluctuations due to pump optimization)
- Device limited by T_{crit} of Nb ground plane
- Contrary to aluminum Josephson TWPA operation above 1K possible with SNR improvement over mK bypass configuration

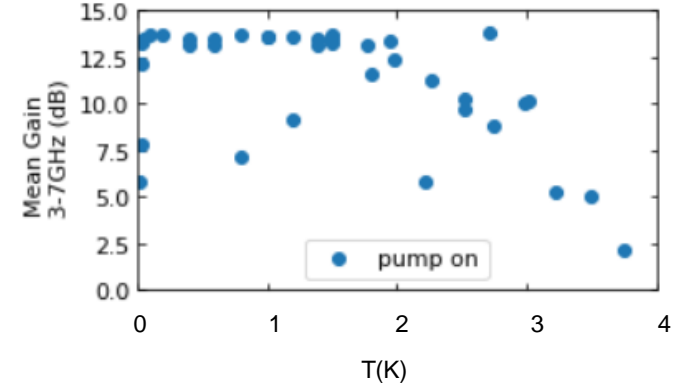
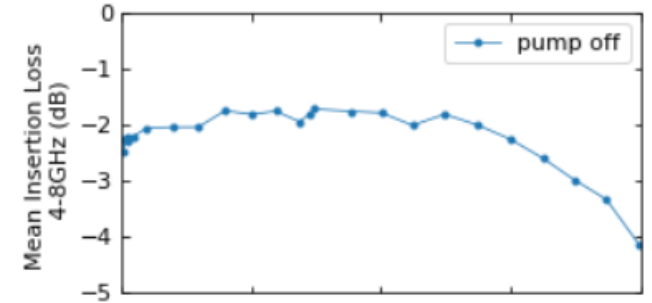
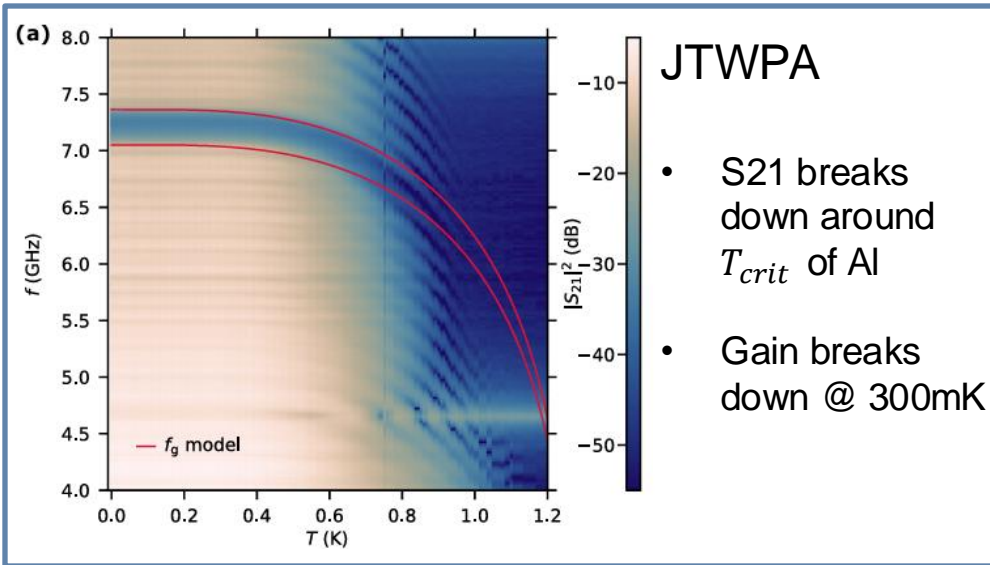

Janssen et al., in prep & @ APS March Meeting (2025)

Stay tuned for

NbN Device_A (bandgap >20GHz); 4K 11/03/23

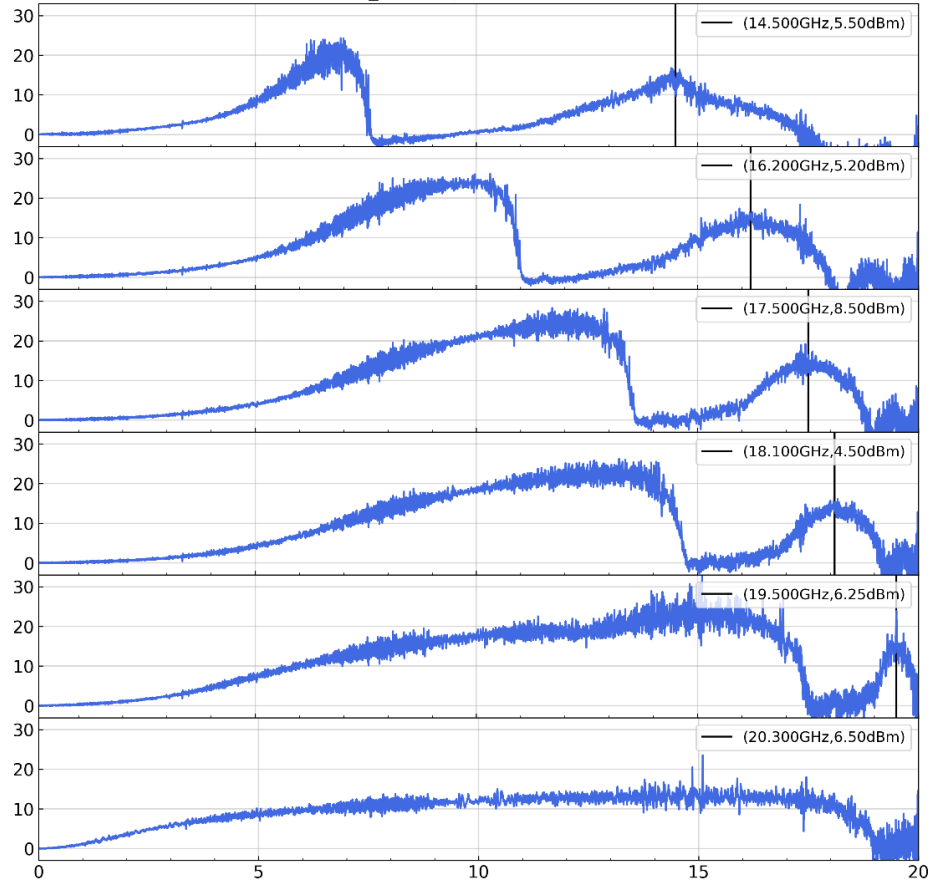

Sub-GHz Device Design

- Applications:
 - Photon counting MKIDs wavelength down to 200 μm
 - Dark sector searches, spin-qubit readout
- 450 mm, Meander for compactness
- Kinetic inductance per square ~ 9 pH/sq
- Titanium Nitride
 - $I_*^2 \propto T_c^2$ ($T_c = 4.06$ K)
 - Pump power ~ 300 nW for 22 dB of gain (compared to 10 μW)
 - Upper critical field ~ 4.2 Tesla

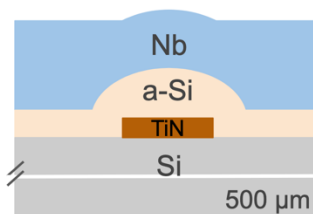

Fabrication stack

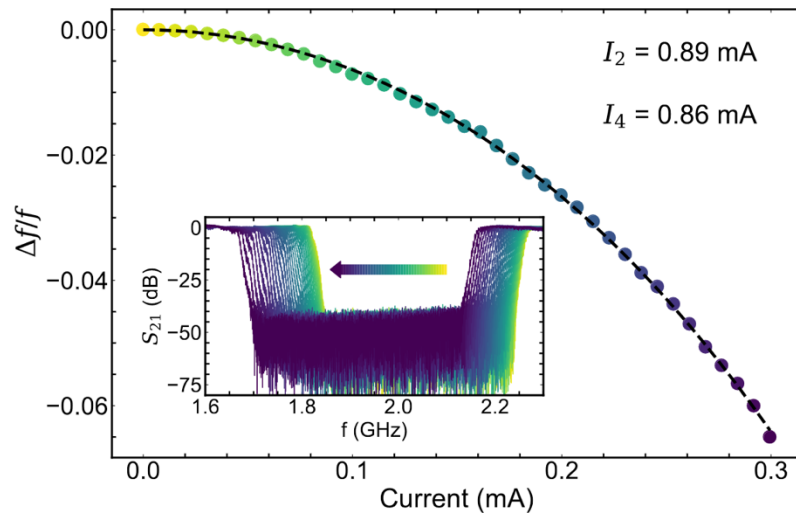
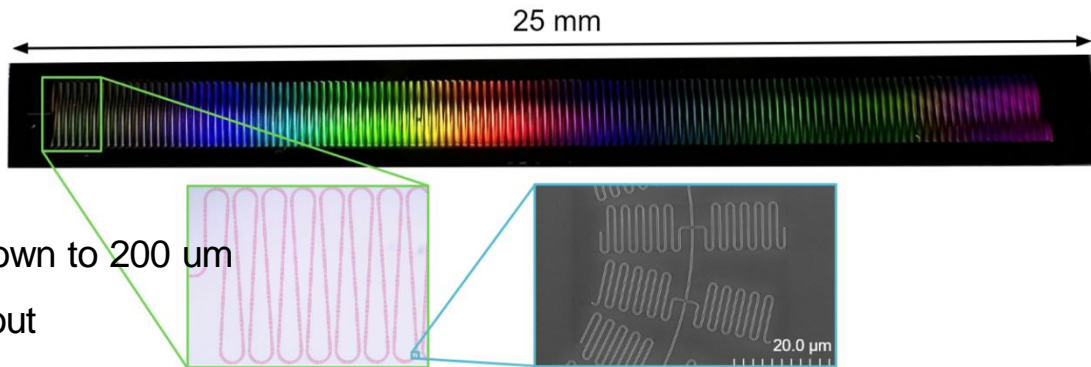

Band stop shift as a function of applied DC current.

F.Faramarzi et al., Arxiv:2406.00530 (2024)

Frequency Translating Mode

- Frequency Translating Gain Mode
 - Advantages
 - Availability of cryo electronics at higher frequency
 - Additional power gain due to photon conversion
 - More tolerant of thermal noise at the idler tones

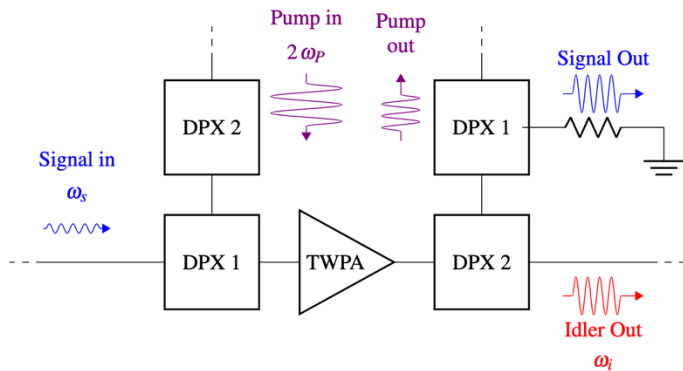

Frequency Translating mode circuit diagram.

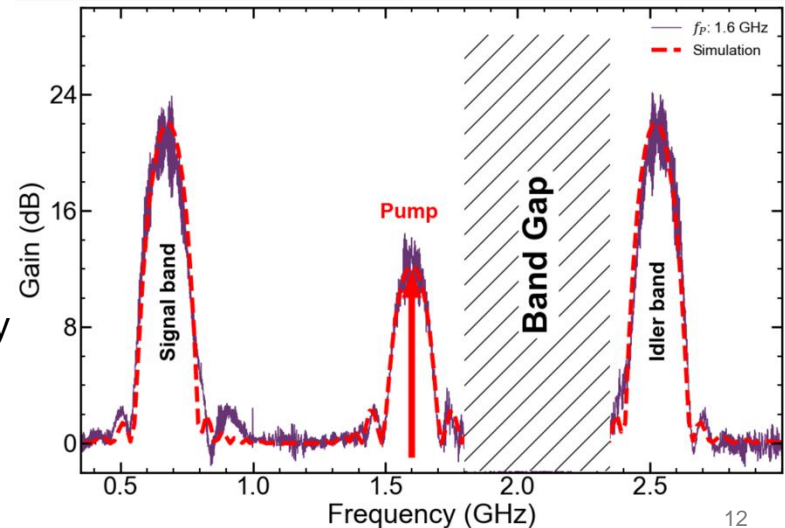

12

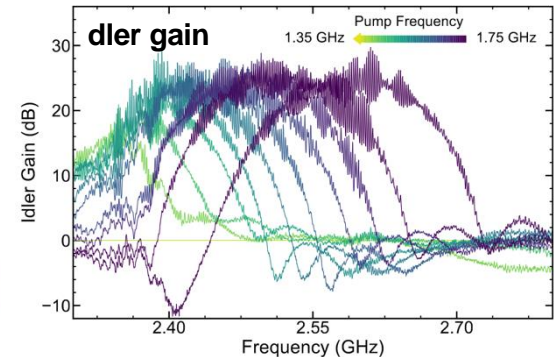
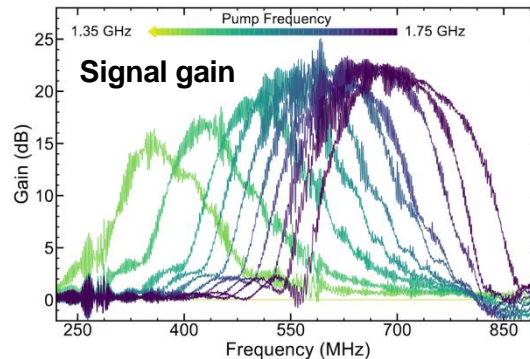

Noise Performance

- Y-factor Method
- Measured in frequency translating circuit
- Near Quantum Limited performance
- High Dynamic Range ($P1dB = -65 \text{ dBm} @ 15 \text{ dB gain}$)

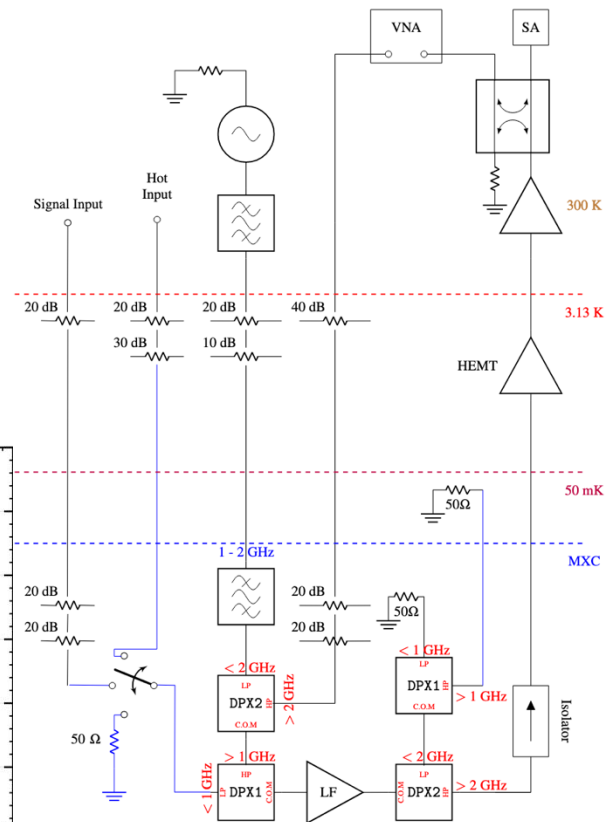
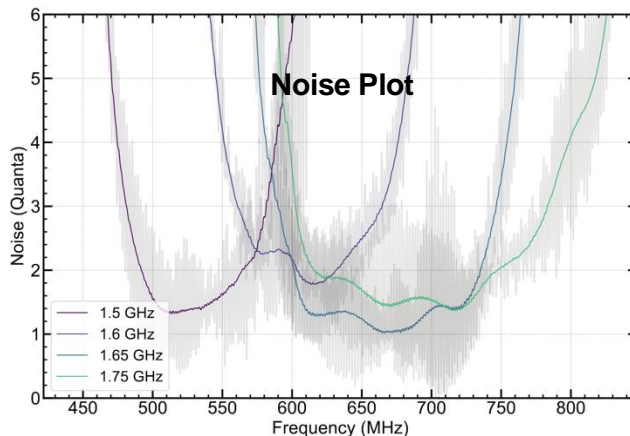
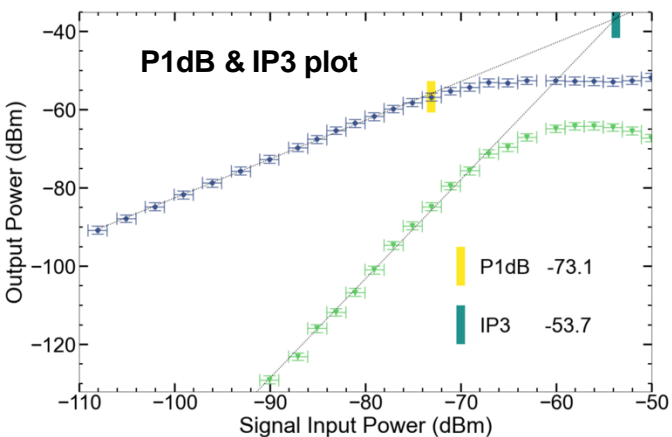
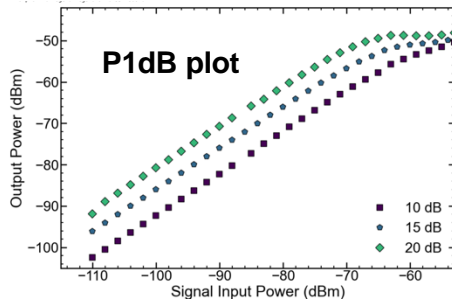

Y-factor noise setup.

Stay tuned for

PA-LL-MoN_LF-D2; 10/30 1K

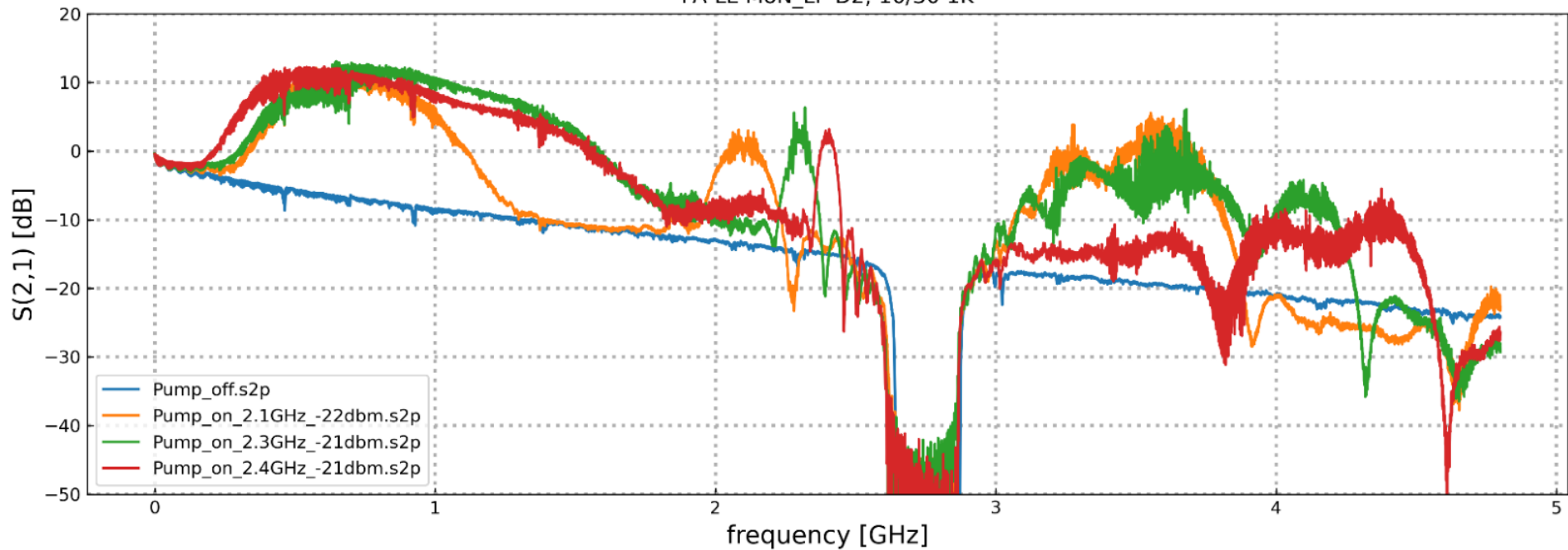

Extending Operation to mm-Waves & Beyond

B.K. Tan, et al., Supercond. Sci. Technol. 37, 035006 (2024).

- Miniaturize devices for high-frequency operation
- Fabrication process
 - NbTiN , NbN ($T_c \sim 16K$), MgB2 ($T_c \sim 30K$)
 - 100-micron substrate thickness (SOI wafer)
- Radiometer, spectrometer, DSN applications

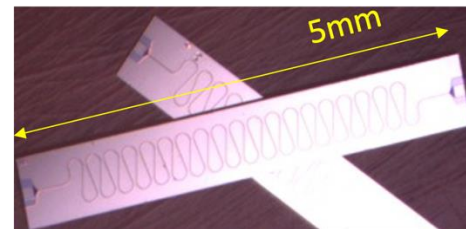

Nb GND plane



NbTiN Microstripline

Waveguide probe

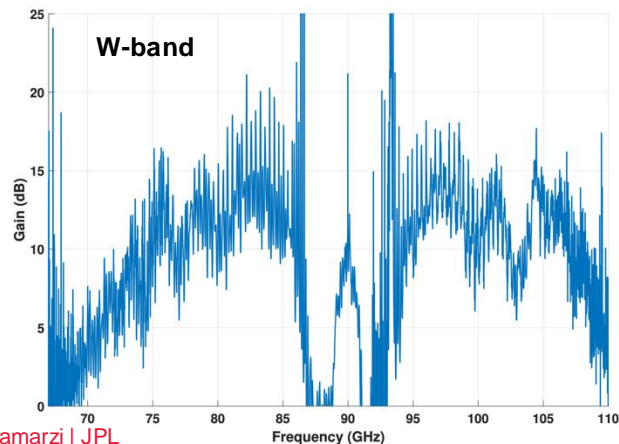
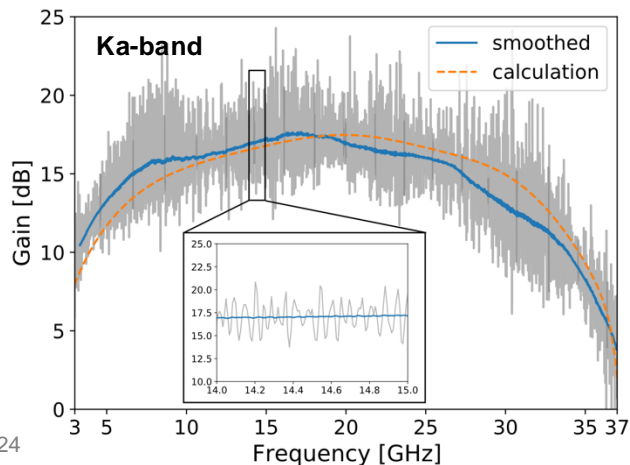

Noise approaches the quantum limit

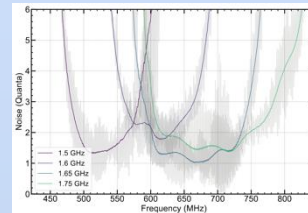
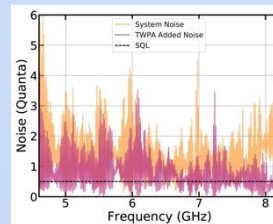

Suitable for readout of various cryogenic detector & qubit technologies

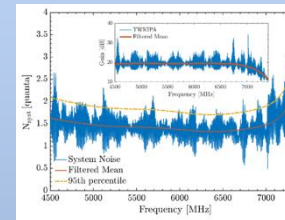
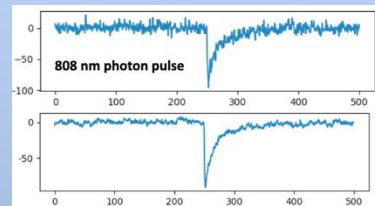

Versatile operating mode

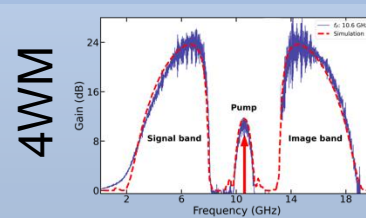
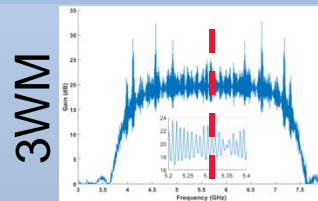

Different frequency ranges

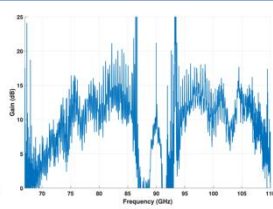
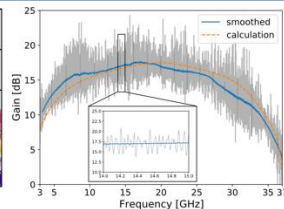
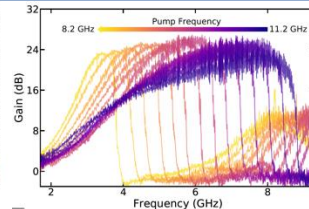
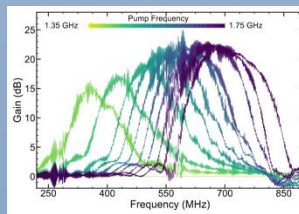



Jet Propulsion Laboratory
California Institute of Technology

jpl.nasa.gov

Let's Collaborate!!

faramarzi@jpl.nasa.gov