

MPGD Trackers in the ePIC Detector at the EIC

Kondo Gnanvo

Radiation Detectors & Imaging Group (RD&I Group), Jefferson Lab, Virginia

On behalf of the ePIC Collaboration

- ❖ Overview of the MPGD Subsystems in the ePIC Central Tracker

- ❖ The μ RWELL Barrel Outer Tracker (μ RWELL-BOT)

- ❖ The Cylindrical Micromegas Barrel Inner Layer (CyMBAL)

- ❖ The μ RWELL End Cap Trackers (μ RWELL-ECT)

- ❖ ePIC MPGD SALSA Readout Electronics

EIC is the flagship Nuclear Physics (NP) Facility in the US (2031+)

- ❖ **High Luminosity:** $L = 10^{33} - 10^{34} \text{cm}^{-2}\text{sec}^{-1}$, 10 – 100 $\text{fb}^{-1}/\text{year}$
- ❖ **Highly Polarized Beams:** 70%
- ❖ **Large Center of Mass Energy Range:** $E_{\text{cm}} = 20 - 140 \text{ GeV}$
- ❖ **Large Ion Species Range:** Protons – Uranium
- ❖ **Particle production rate:** ~ 5 @ 500 kHz
- ❖ **ePIC Detector:** Large Acceptance and Good Background Conditions

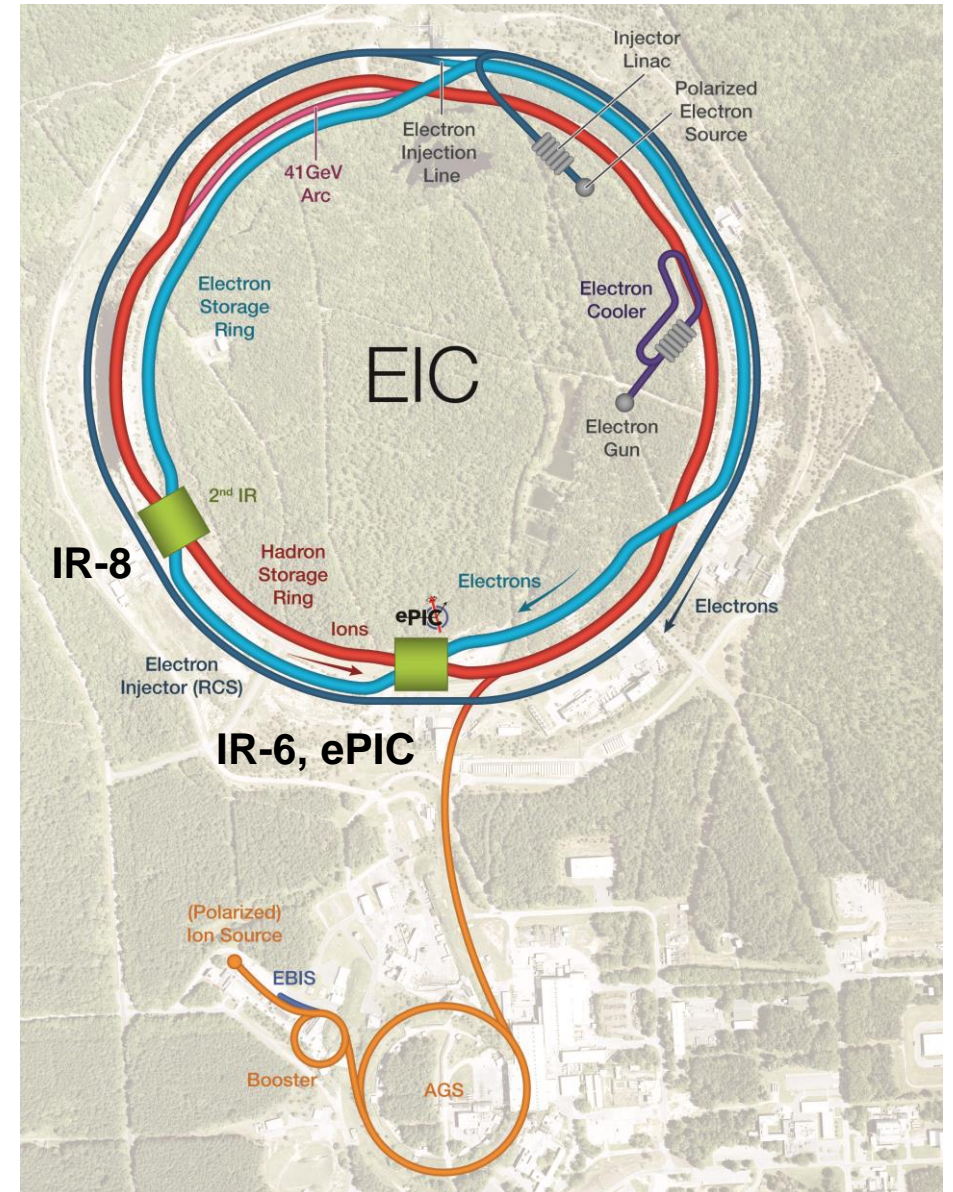
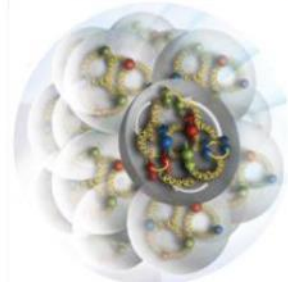
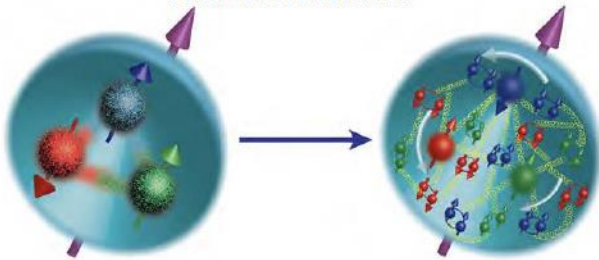
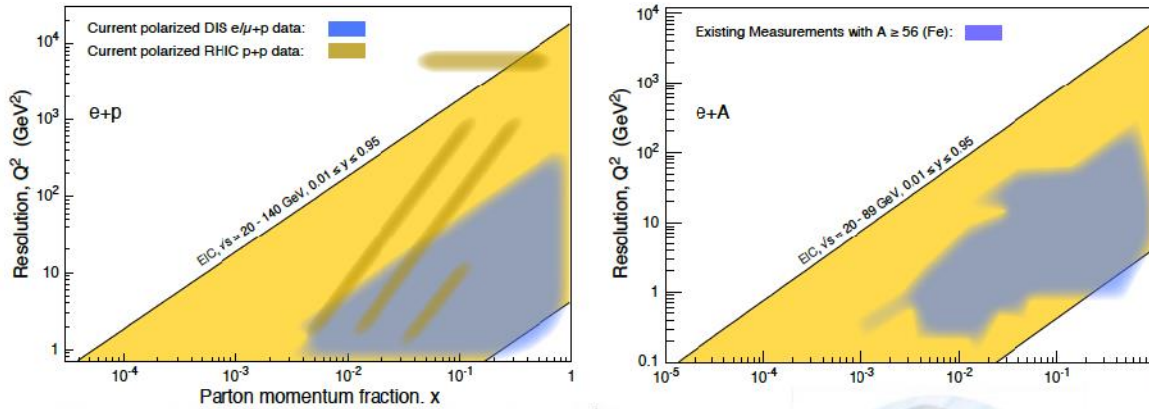

Vertexing and Tracking:

- Silicon Vertex Tracker (MAPS)
- MPGD (μ RWELL/ μ Megas)

Particle Identification:

- TOF (AC-LGAD also for tracking)
- pfRICH (Aerogel/HRPPD)
- hpDIRC (Quartz/MCP-PMT)
- dRICH (Aerogel+C₂F₆/MCP-PMT)

EM Calorimeters:

- EEMCal (PbWO₄/SiPM)
- Barrel EMCal (Pb+SciFi/SiPM) with imaging layers (Pb+SciFi/AstroPix)
- FEMC (W+SciFi)

Hadronic Calorimeters:

- Backward HCal (Fe+Sc/SiPM)
- Barrel HCal (sPHENIX re-use)
- LFHCal (Fe+Sc&W+Sc/SiPM)

Far-Backward:

- Luminosity monitor (AC-LGAD, W+SciFi)
- Low-Q² tagger (Si/Timepix4)

Far-Forward:

- Roman Pots (AC-LGAD)
- B0 Magnet Spectrometer (AC-LGAD, PbWO₄)
- Off-Momentum Detector (AC-LGAD)
- Zero Degree Calorimeter (PbWO₄, Fe/SiPM)

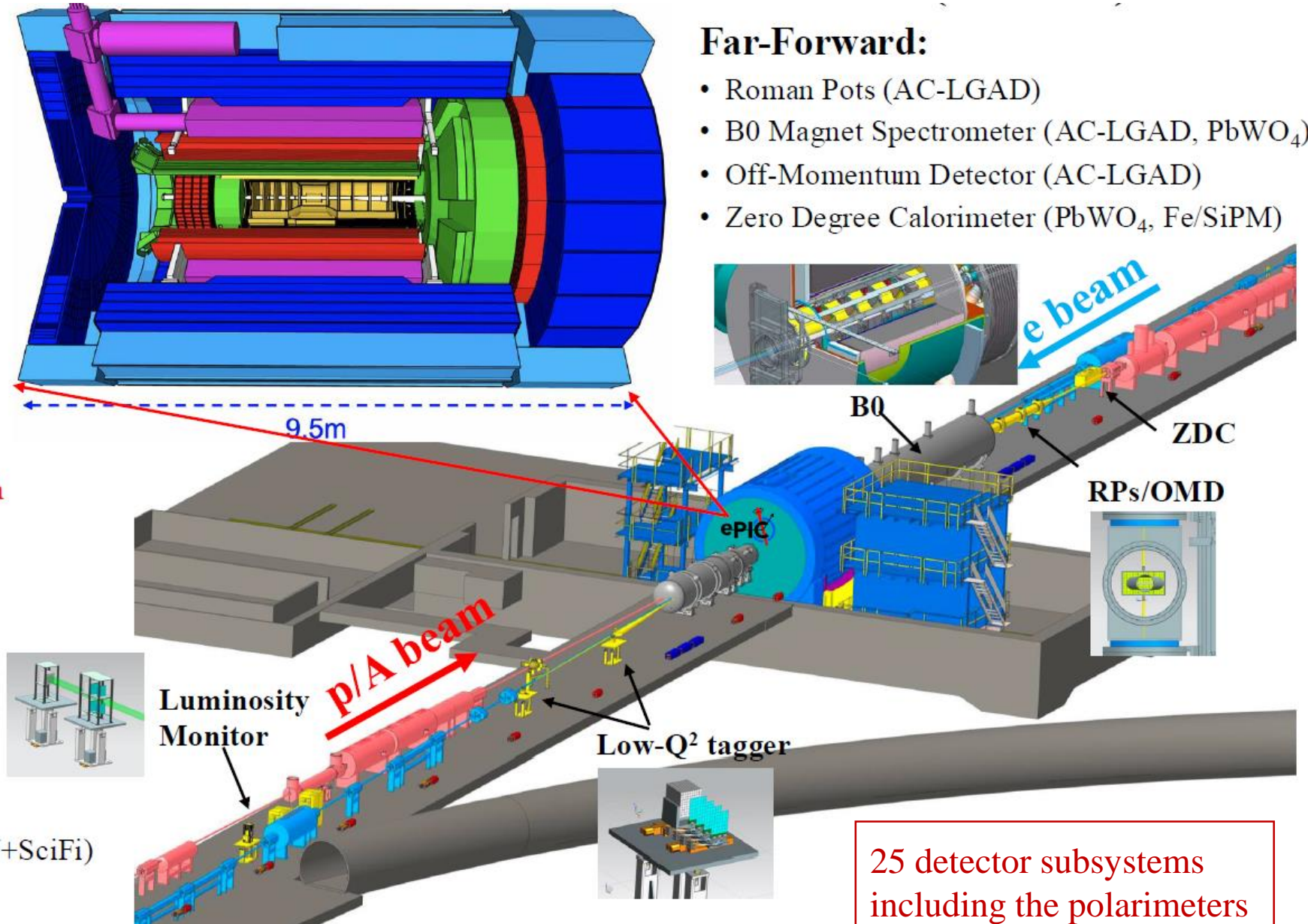

25 detector subsystems including the polarimeters

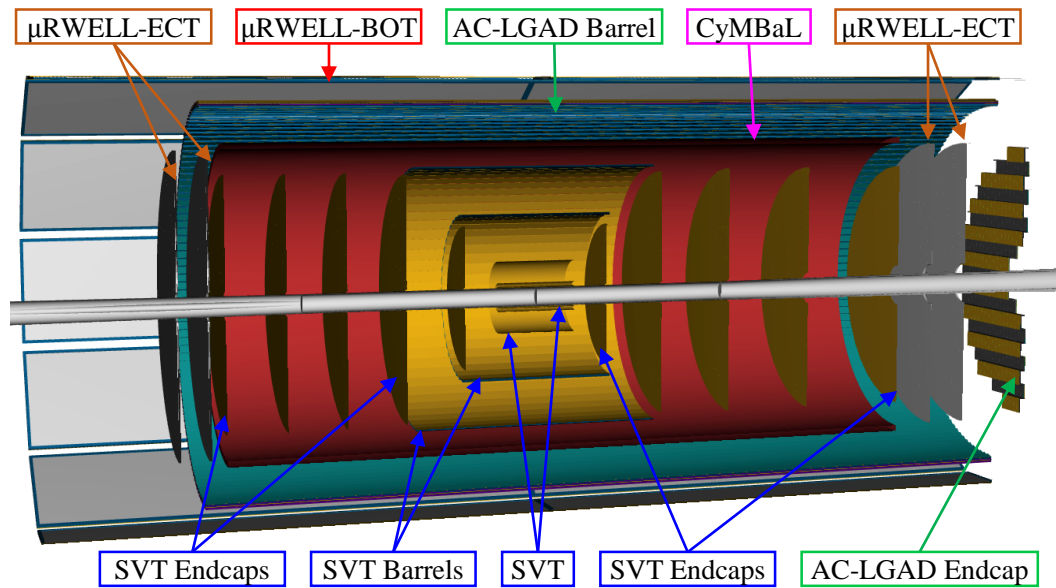

Silicon Vertex Tracker (SVT): $\sim 6 \mu\text{m}$ point resolution

- ❖ 3 inner barrels: ITS3-curved wafer-scale sensor, 0.05% X/X0
- ❖ 2 outer barrels: ITS3-based sensors (EIC-LAS), 0.25/0.55% X/X0
- ❖ 5 disks (forward/backward), EIC-LAS, 0.25% X/X0

Micro Pattern Gaseous Detectors (MPGD): 10 ns & 150 μm resolutions

- ❖ **2 × 2 End cap disks: GEM- μRWELL hybrid detectors**
- ❖ **One inner barrel layer: Cylindrical Micromegas**
- ❖ **One outer barrel layer: Thin-gap GEM- μRWELL hybrid detectors**

AC-coupled LGAD TOF: 30 μm + 30 ps resolutions

- ❖ Barrel TOF: 0.05 x 1 cm strip, 1% X/X0
- ❖ Forward TOF: 0.05 x 0.05 cm pixel, 5% X/X0

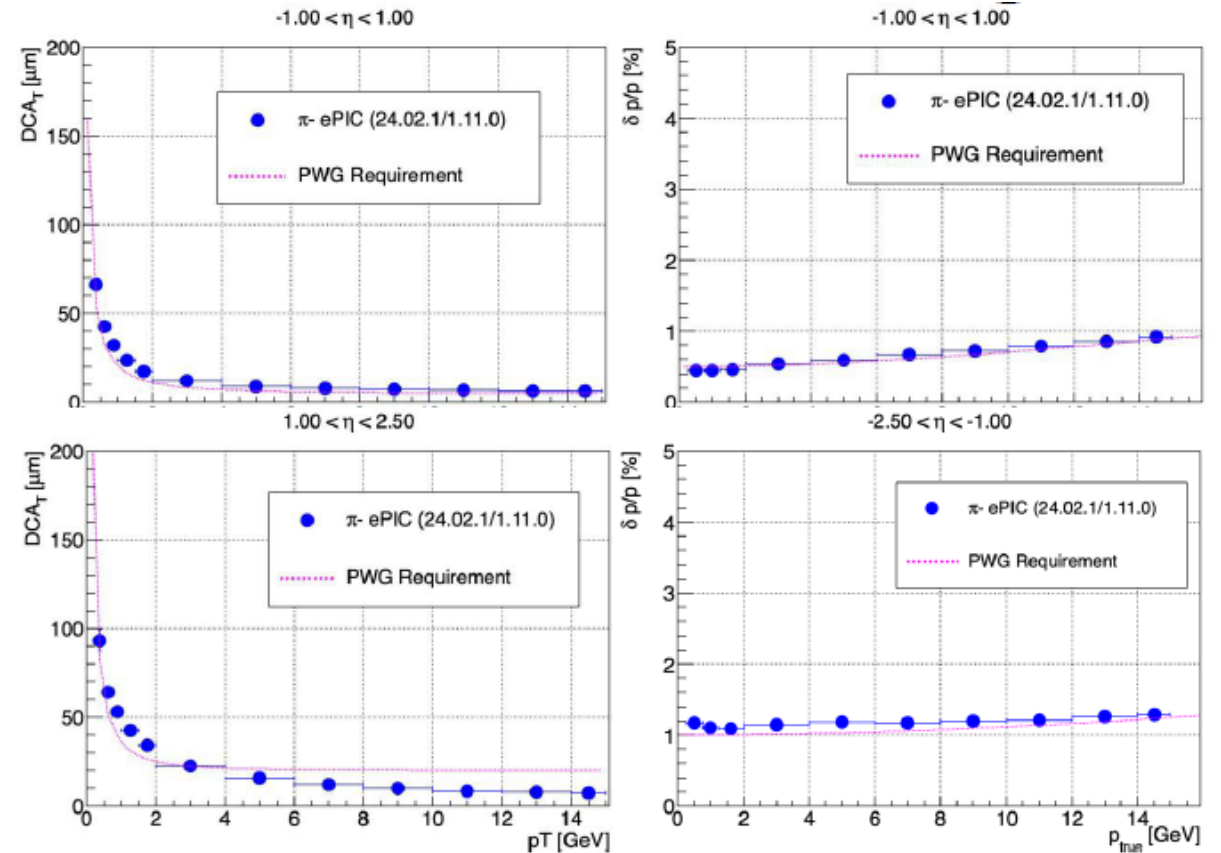

Rapidity Range	Momentum Resolution	Spatial Resolution
Backward (-3.5 to -2.5)	$\sim 0.10\% \times p \oplus 2.0\%$	$\sim 30/pT \mu\text{m} \oplus 40\mu\text{m}$
Backward (-2.5 to -1.0)	$\sim 0.05\% \times p \oplus 1.0\%$	$\sim 30/pT \mu\text{m} \oplus 20\mu\text{m}$
Barrel (-1.0 to 1.0)	$\sim 0.05\% \times p \oplus 0.5\%$	$\sim 20/pT \mu\text{m} \oplus 5\mu\text{m}$
Forward (1.0 to 2.5)	$\sim 0.05\% \times p \oplus 1.0\%$	$\sim 30/pT \mu\text{m} \oplus 20\mu\text{m}$
Forward (2.5 to 3.5)	$\sim 0.10\% \times p \oplus 2.0\%$	$\sim 30/pT \mu\text{m} \oplus 40\mu\text{m}$

3 MPGD subsystems in ePIC Central tracking detectors:

- ❖ **CyMBAL**: Barrel Inner Cylindrical Micromegas Layer
- ❖ **μ RWELL-BOT**: Barrel Outer MPGD tracker
- ❖ **μ RWELL-ECT**: End cap MPGD disks

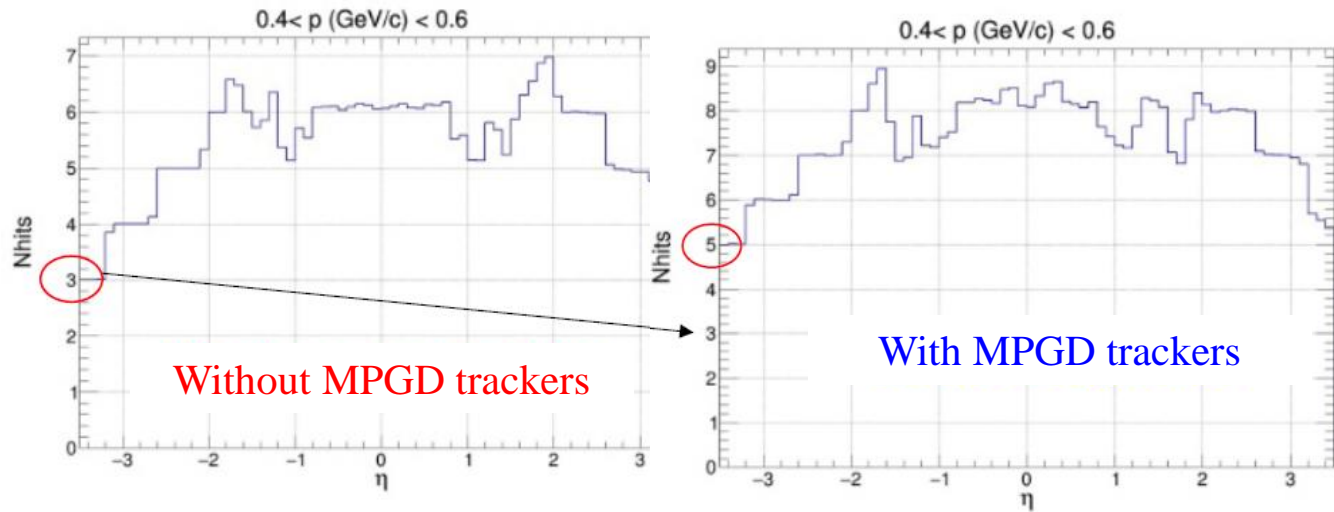

MPGD tracking detectors in ePIC central region aim at

complementing the Si trackers to provide

- ❖ Fast timing (10 ns) for pattern recognition
 - ❖ additional space points ($< 150 \mu\text{m}$) for pattern recognition
- and help improve angular resolution at the hpDIRC level

• GEANT-level tracker hits showing geometric coverage

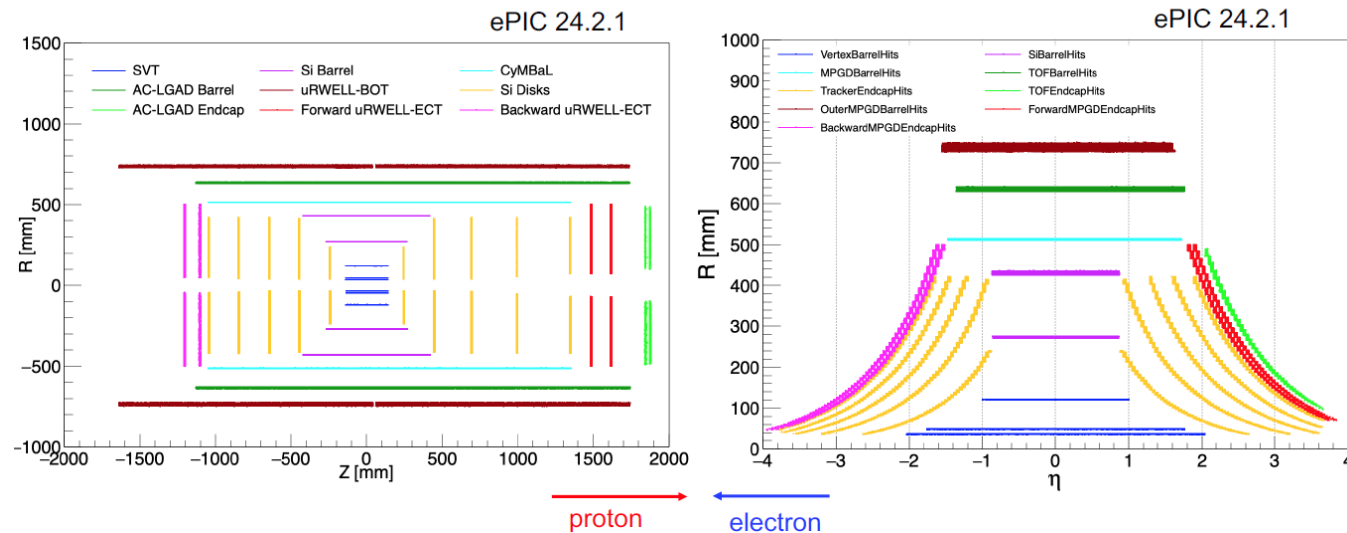

Cylindrical Micromegas Barrel Layer (CyMBAL)

CyMBaL layout in ePIC

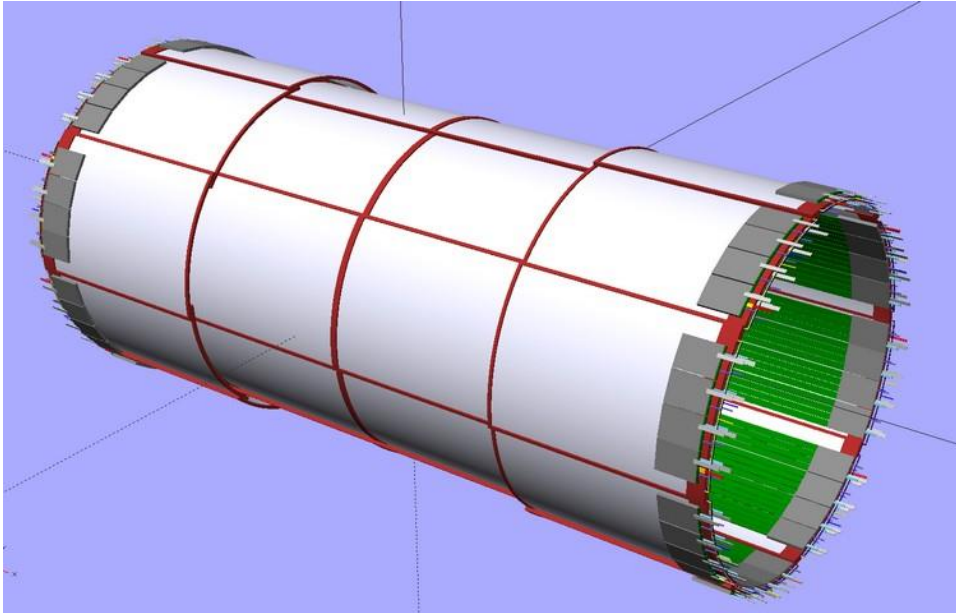

CyMBAL module design

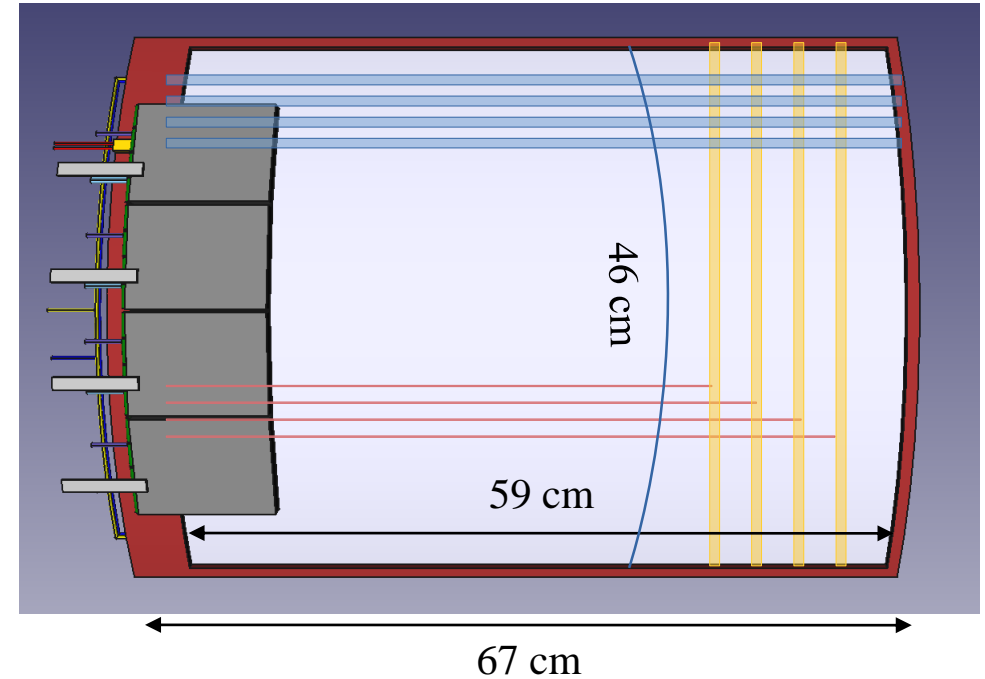

Requirements:

- ❖ Spatial resolution $\sim 150\mu\text{m}$
- ❖ Time resolution $\sim 10\text{ns}$
- ❖ Light, less than 1% X0
- ❖ Hermetic
- ❖ Tight space: $\sim 5\text{cm}$ in R
- ❖ Magnetic field: $\sim 2\text{T}$

Detector layout:

- ❖ 32 modules: 8 modules in $\phi \times 4$ modules in z
- ❖ Full overlaps in ϕ and in z for hermeticity
- ❖ 1024 readout channels/module
- ❖ 32K readout channels

Module dimensions

- ❖ Z = 67 cm
- ❖ R*phi = 48 cm

Active zone dimensions

- ❖ Z = 59 cm
- ❖ R*phi = 46 cm

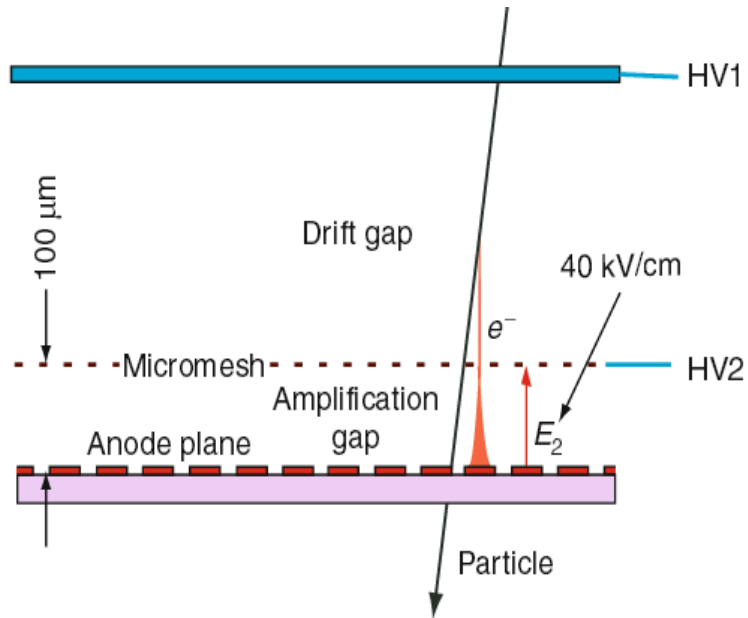

[Y. Giomataris, NIMA 419 \(1998\) 239](#)

Curved CLAS12 MVT module

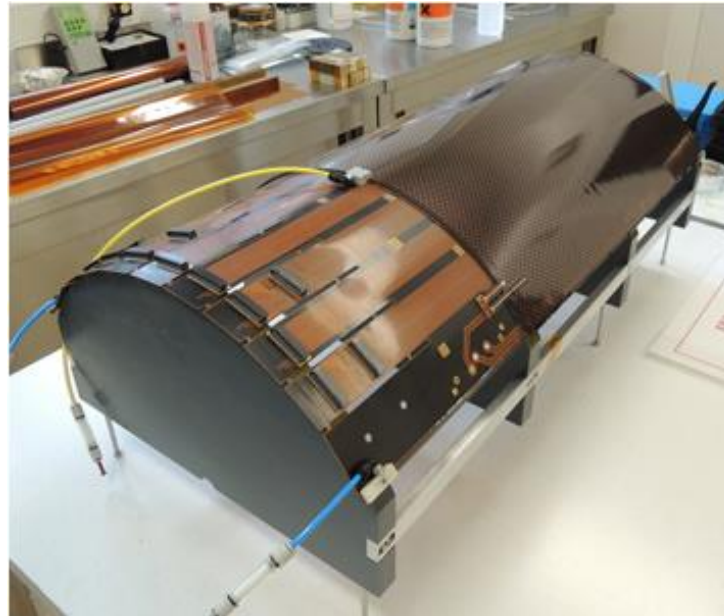

Material budget ~0.4%

CLAS12 Micromegas Vertex Tracker (MVT) @ JLab

- ❖ Resistive Micromegas technology
- ❖ High radiation environment @ $B = 5T$
- ❖ Taking data since 2017

Upgrade for CyMBAL modules:

- ❖ Larger size modules
- ❖ 2D strip readout

CLAS12 MVT: 6 layers fit in tight space

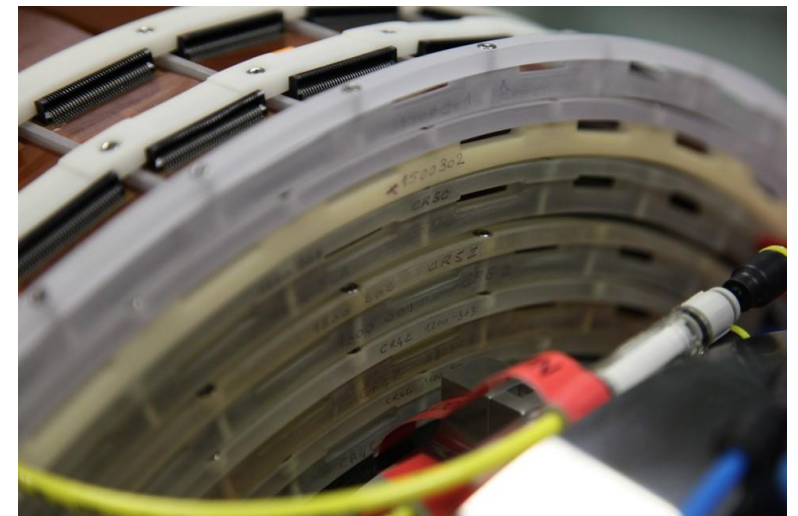

Ongoing R&D effort: Analysis of the 2023 & 2024 test beam data on the 2D prototypes

- ❖ Complete the tests on resistive patterns and 2D readout with new prototypes
- ❖ Design & production of large scale prototype with 2D readout using CLAS12 mechanics
- ❖ Mechanical mock-up for a scale 1:1 prototype
- ❖ Test performance of a small 2D prototype with a 1mm drift gap with different gas

Several 12 cm × 12 cm low material budget (0.2% X0) micromegas prototypes tested with various R/O pattern and resistive motifs

Straight strips

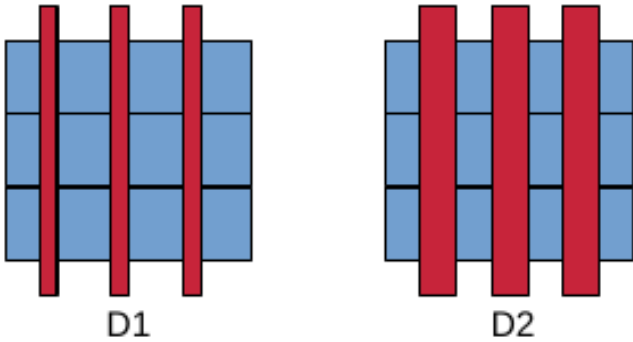

- ❖ D1: pitch from 0.5 to 1.5 mm, interstrip 25%
- ❖ D2: pitch 1 mm, interstrip 50%
- ❖ Resistive layer: full, resistivity $\sim 10\text{M}\Omega/\square$

ASACUSA strips

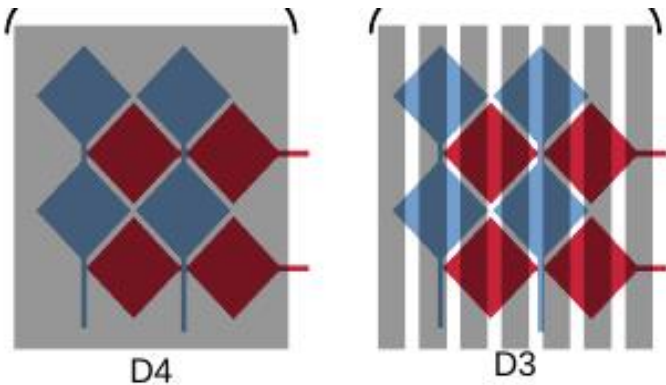

- ❖ D3: resistive strips of 500 μm pitch
- ❖ D4: full layer with resistivity $\sim 500\text{k}\Omega/\square$

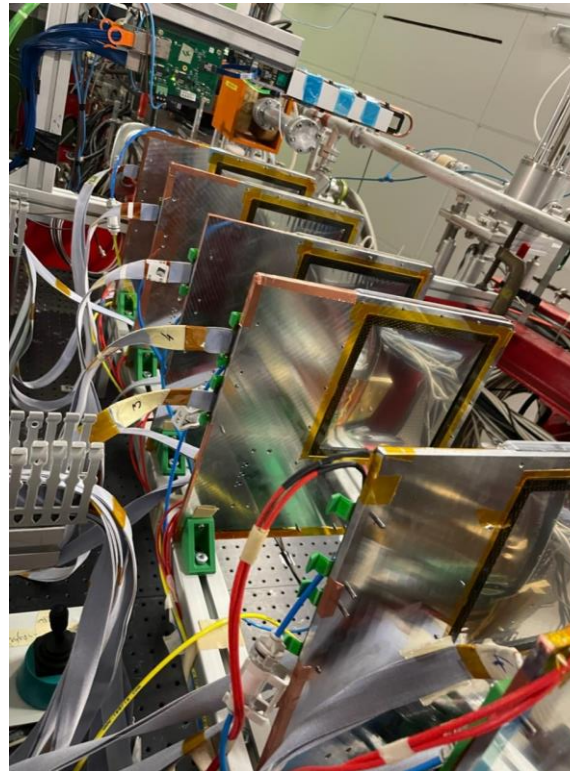

MAMI beam test (June 2023)

- ❖ 880 MeV electron beam
- ❖ ALPIDE-based reference telescope
- ❖ Important multiple scattering effect
- ❖ Geant4 simulations to cross check

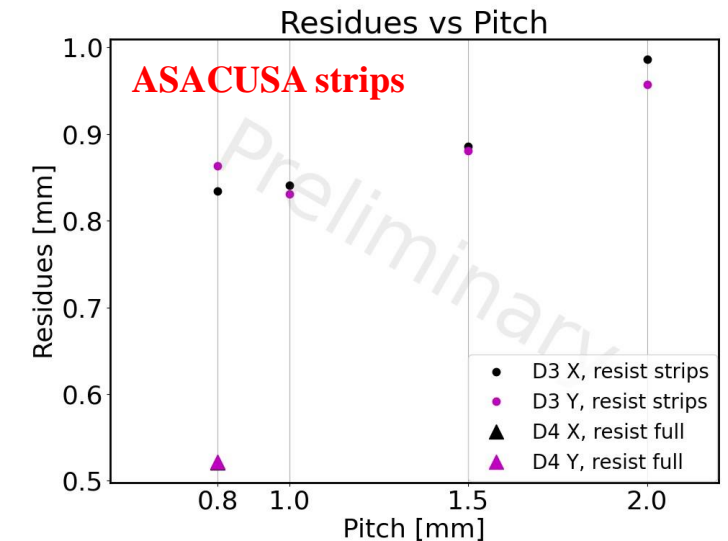
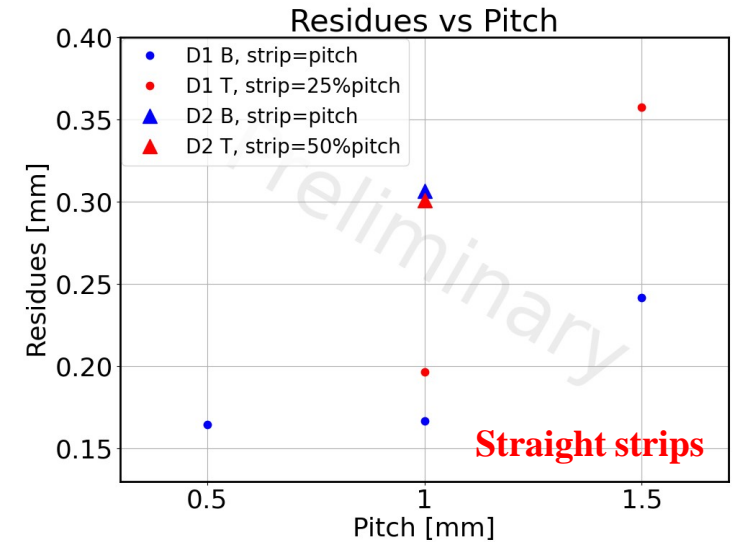

Mesh tensioning system: it allows us to reach low tension values

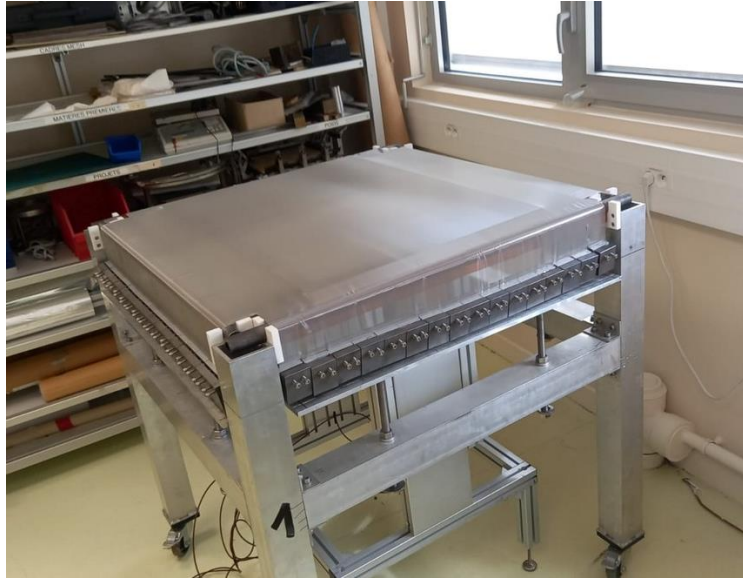

- Bulk of a resistive CLAS12 PCB
- Bent in shape

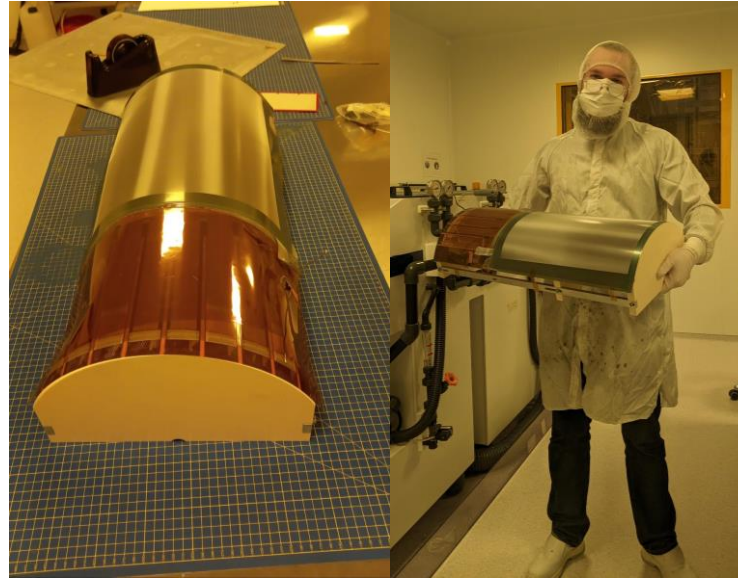

Low material budget: Achieved by stretching flexible PCB on a carbon frame

Mesh – resistive layer

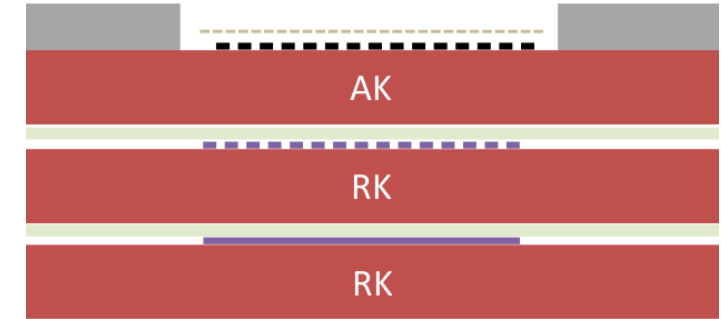

R/O flexible PCB (Kapton)

Photo-resistive material:

- ❖ Pyralux out of production
- ❖ Switched to Vacrel (was used in the past)
- ❖ Difference film thickness (from 64 μm to 50 μm)
- ❖ Difference in composition:
 - Check adherence
 - Adjustments of the development stage
- ❖ Tests with 40x40cm² detectors ongoing

μ RWELL-BOT Layout

- ❖ $L = 340 \text{ cm}$ ($-165 \text{ cm} \leq Z \leq 175 \text{ cm}$), $R = 72.5 \text{ cm}$
- ❖ 24 modules in 12-sided polygon shape trackers
 - Segmented into 12 sectors along φ
 - 2 modules (left & right) per sector along z
- ❖ Fast timing layer $\sim 10 \text{ ns}$
- ❖ Radiation length $< 2\%$ in active area

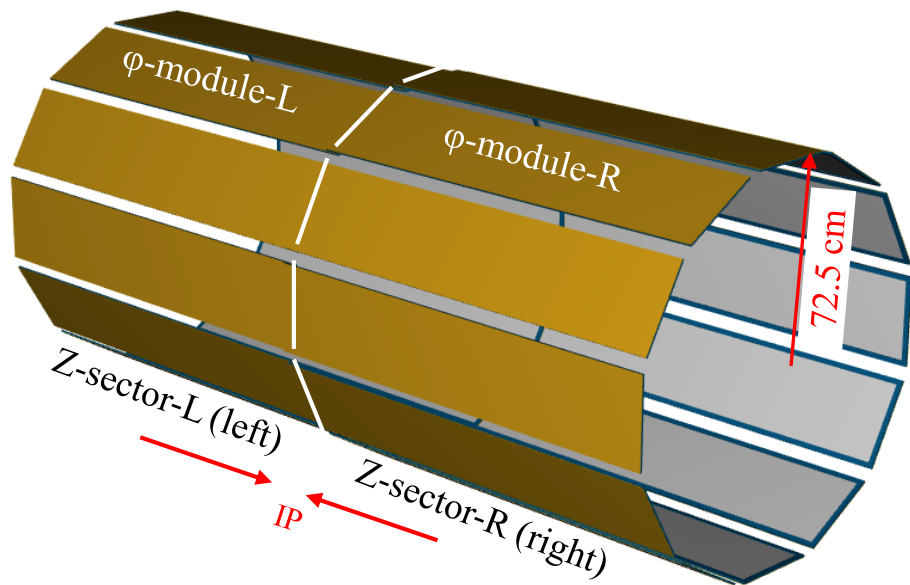

μ RWELL-BOT layer in dodecagon shape

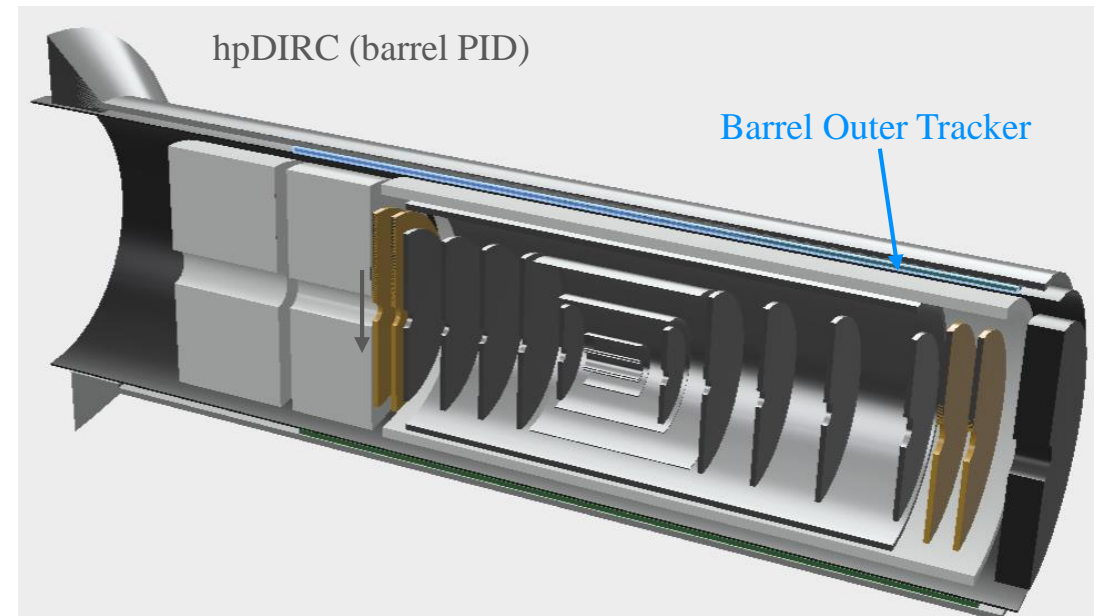

μ RWELL-BOT Tracker in ePIC central detector

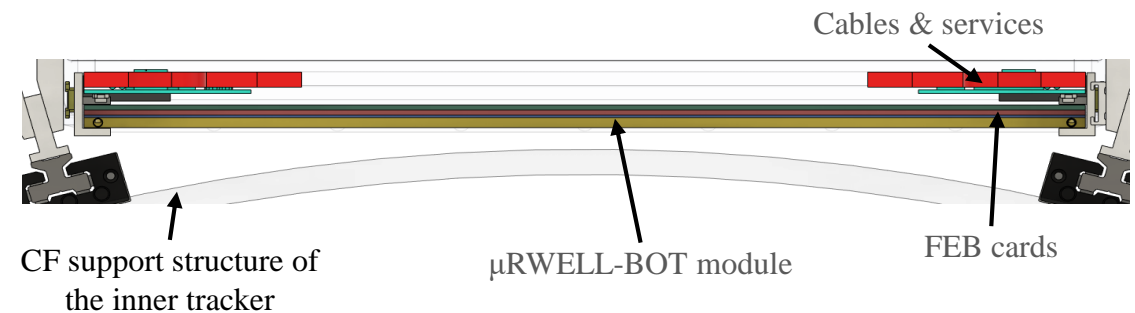

Front view of μ RWELL-BOT module

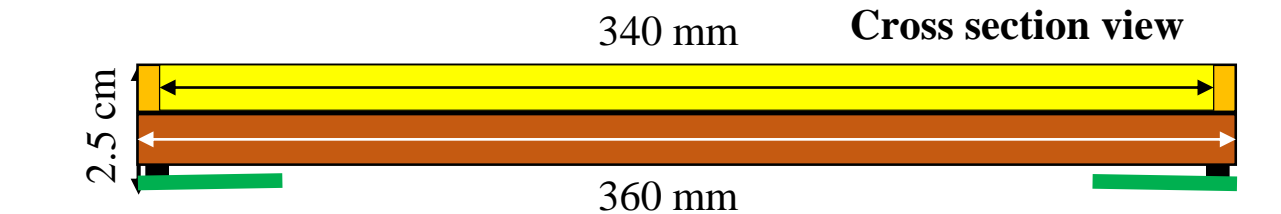
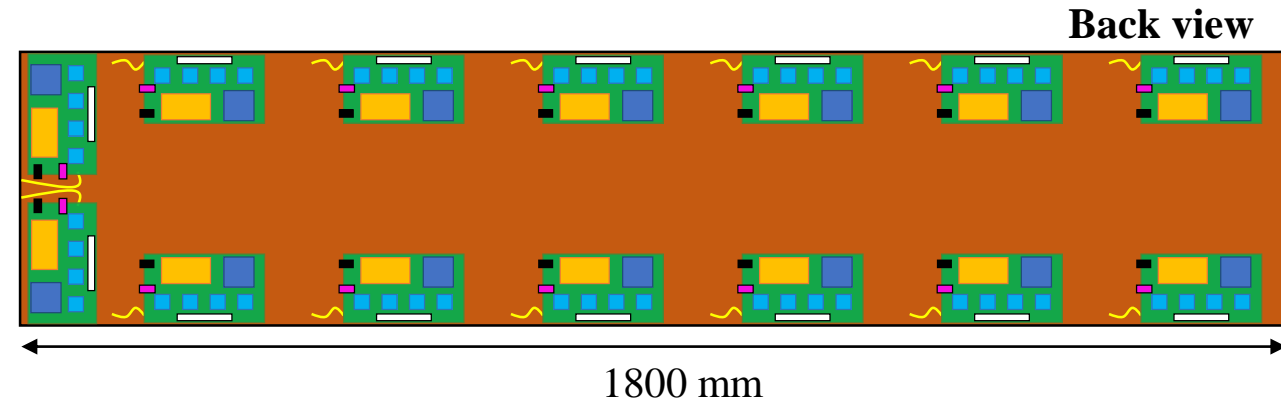
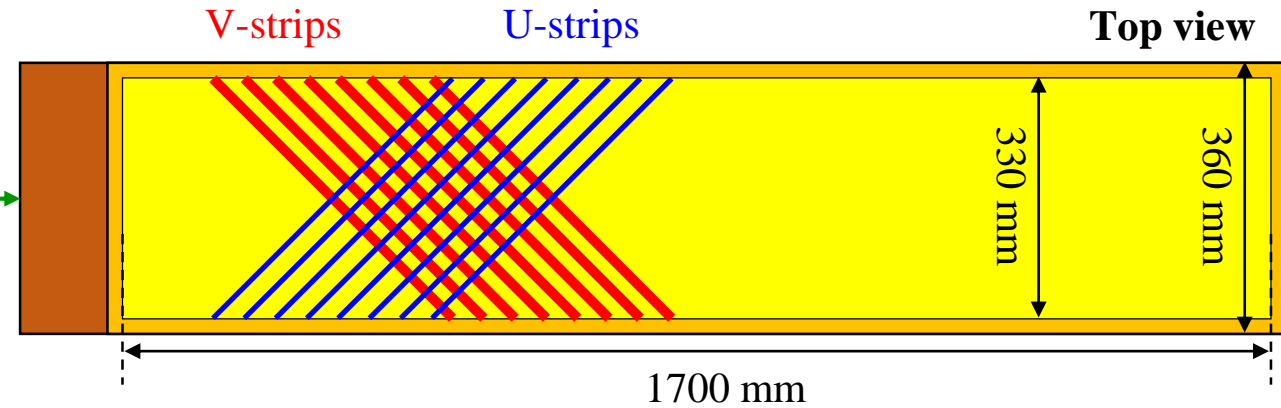
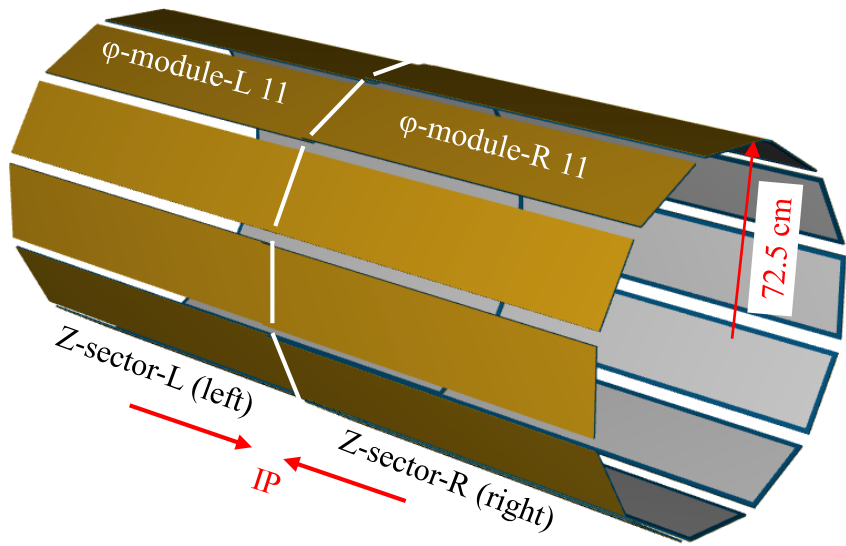

μ RWELL-BOT module

- ❖ **Thin-gap double-amplification GEM- μ RWELL hybrid detector**
- ❖ Capacitive-sharing U-V strips readout layers(45° stereo angle)
- ❖ Pitch: 0.8 mm (1790 U-strips and 1790 V-strips per modules)

On-detector Front End Boards (FEBs)

- ❖ Based on SALSA electronics
- ❖ 14 FEBs / modules
- ❖ Direct connection on the back of modules (no flex cables)

3 critical components of thin-gap MPGDs:

- ❖ **Thin gap drift:** 1 mm gas gap in the ionization region
 - Improve both spatial and time resolution
 - Reduce $E \times B$ effect
- ❖ **Double amplification:** High gain & stable detector operation
 - Hybrid amplification \rightarrow GEM pre-ampl. + μ RWELL for 2nd ampl.
 - Compensate for ionization charges loss in the thin gap
- ❖ **Capacitive-sharing structures:** Coarse pitch / Excellent spatial resolution
 - Versatile readout pattern (U / V, X / Y, zigzag strips ...)
 - [K. Gnanvo, NIM A1047, 167782 \(2023\)](#)

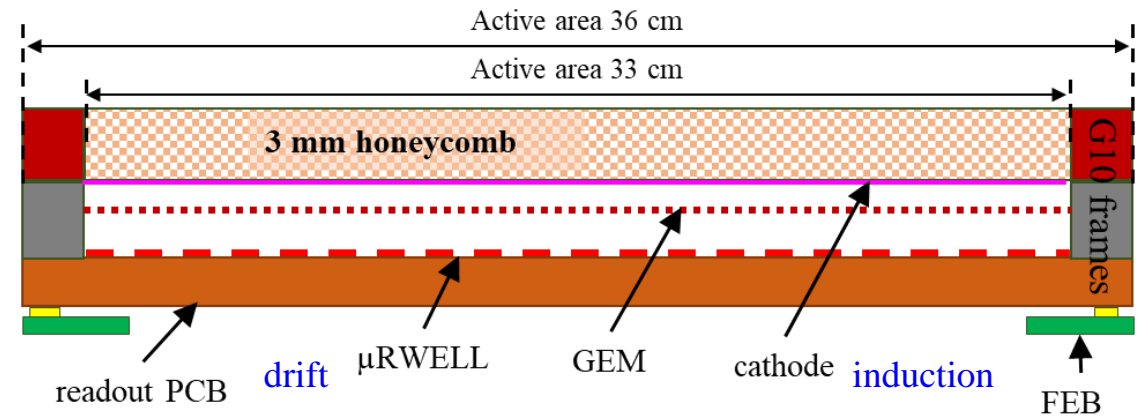

cross-section view of thin-gap GEM- μ RWELL detector

https://indico.jlab.org/event/751/contributions/13585/attachments/10462/15726/20231031_EICGENR D16_ThinGapMPGD_KG.pdf

https://www.jlab.org/sites/default/files/eic_rd_prm/files/2023_Proposals/20230714_eRD_tgMPGD_Proposal_FY23_Final_EICGENRandD2023_16.pdf

Assembly of small (10 cm \times 10 cm) thin-gap GEM- μ RWELL hybrid detector

μ RWELL + readout PCB

Cathode + GEM block

Stack of the hybrid

Final prototype

Capacitive-sharing X-Y strip readout

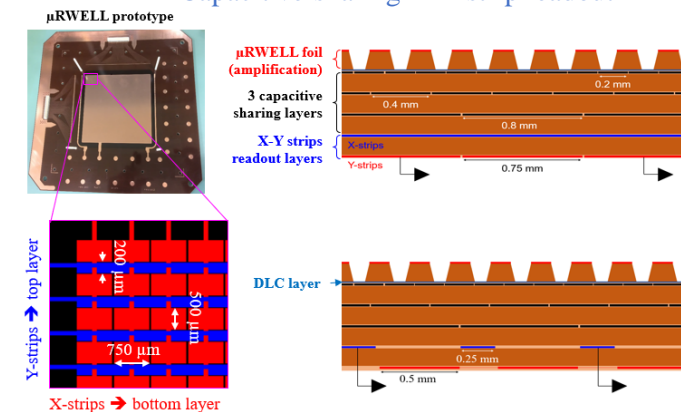
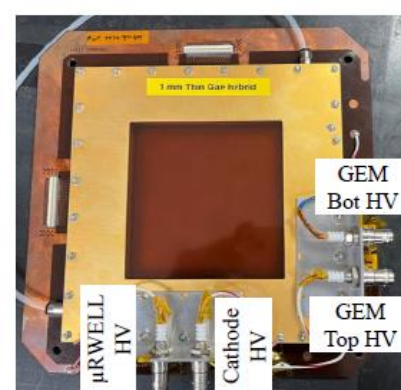
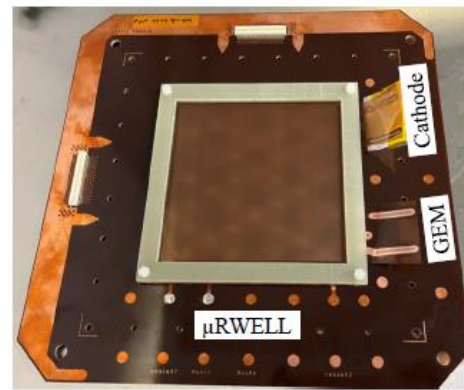
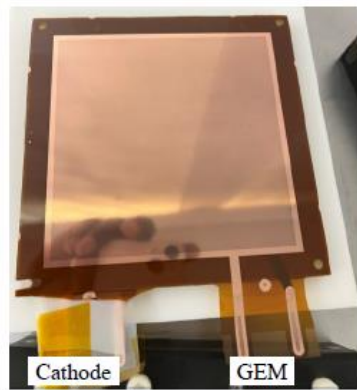
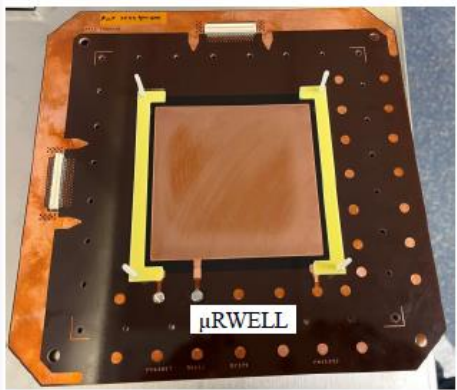

Performance in beam of thin-gap GEM- μ RWELL hybrid (FNAL 2023)

- ❖ ~10 small thin-gap MPGD prototypes tested
 - All 3 MPGD technologies: GEM, μ RWELL, Micromegas tested
- ❖ 2 thin-gap GEM- μ RWELL hybrid & 1 standard gap prototypes
 - 0.5-mm tin-gap, 1-mm thin-gap & 3-mm std-gap

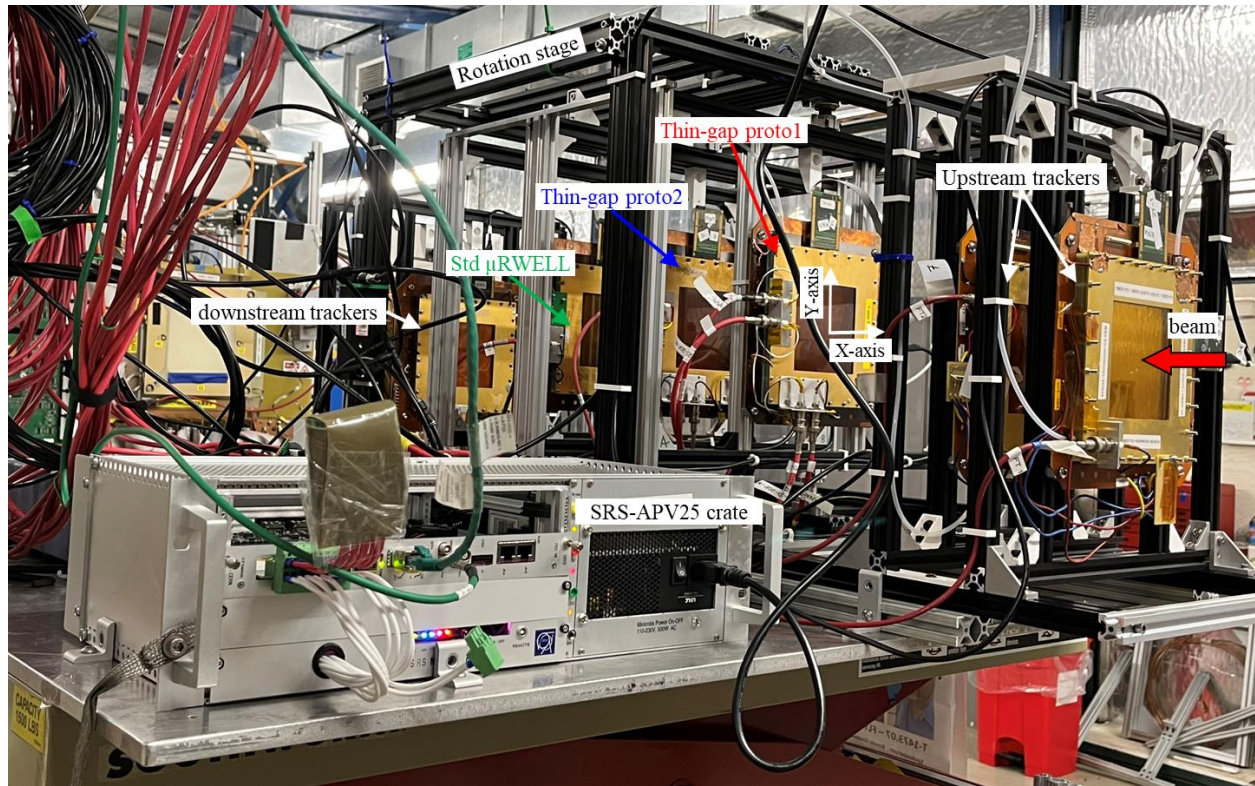

Beam test setup

Space resolution $< 150 \mu\text{m}$ & efficiency $> 92\%$ on for **1-mm prototype (red)** - track angle range of between $0 - 45$ degrees

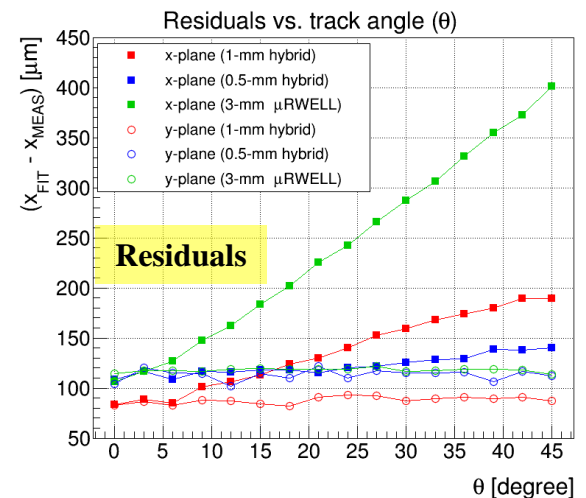
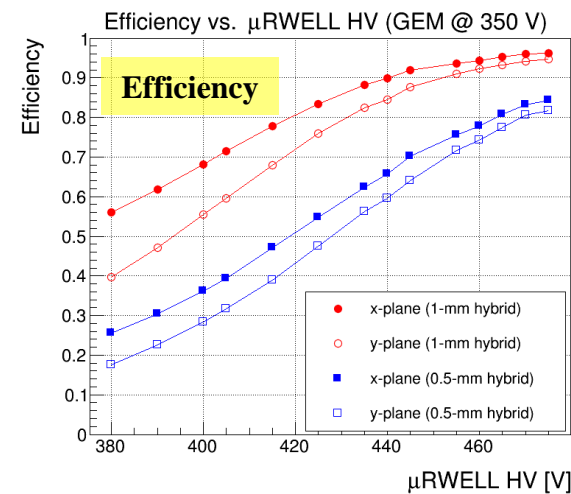
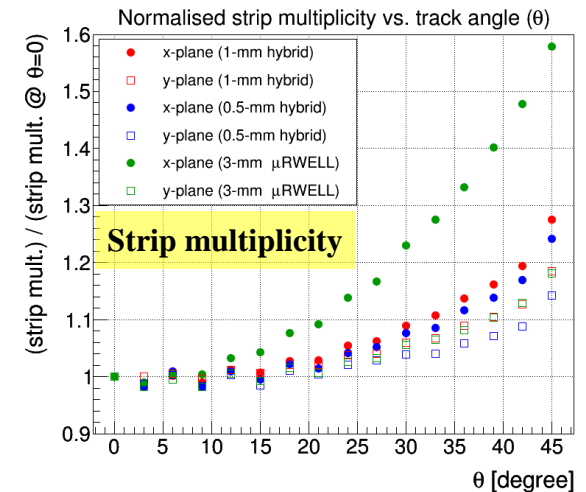
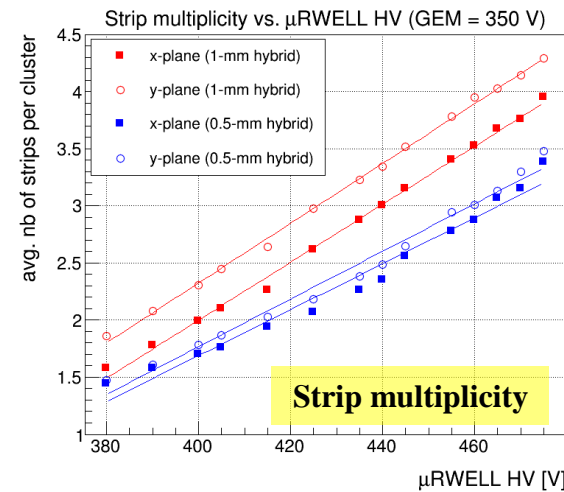

CAD design of thin-gap GEM-μRWELL engineering test article

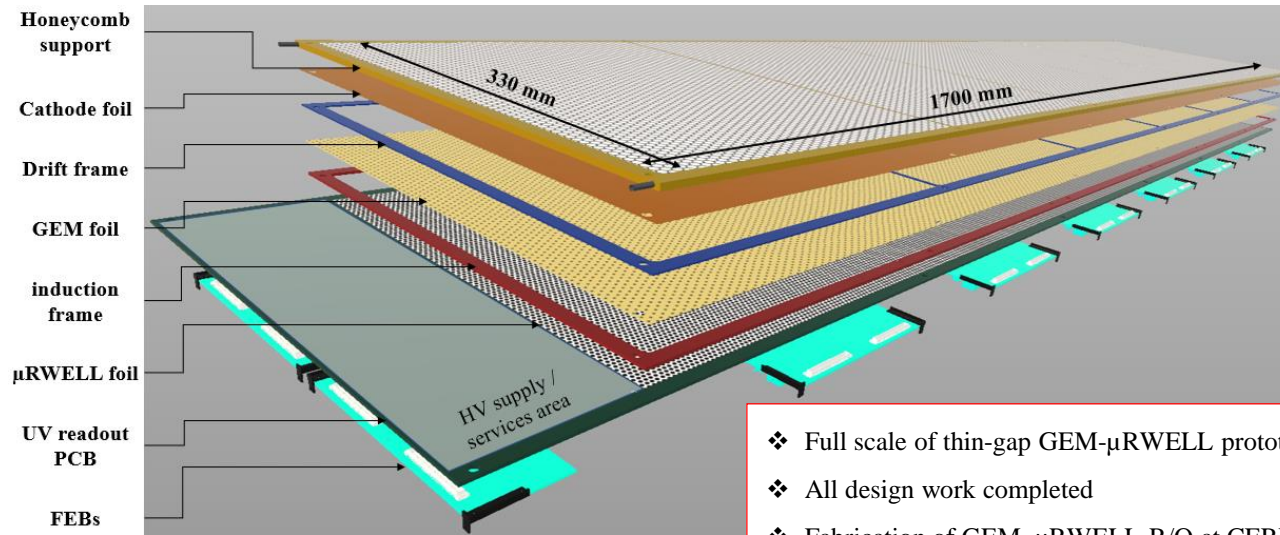

- ❖ Full scale of thin-gap GEM-μRWELL prototype
- ❖ All design work completed
- ❖ Fabrication of GEM, μRWELL-R/O at CERN
- ❖ Assembly and test at JLab → second half off 2025

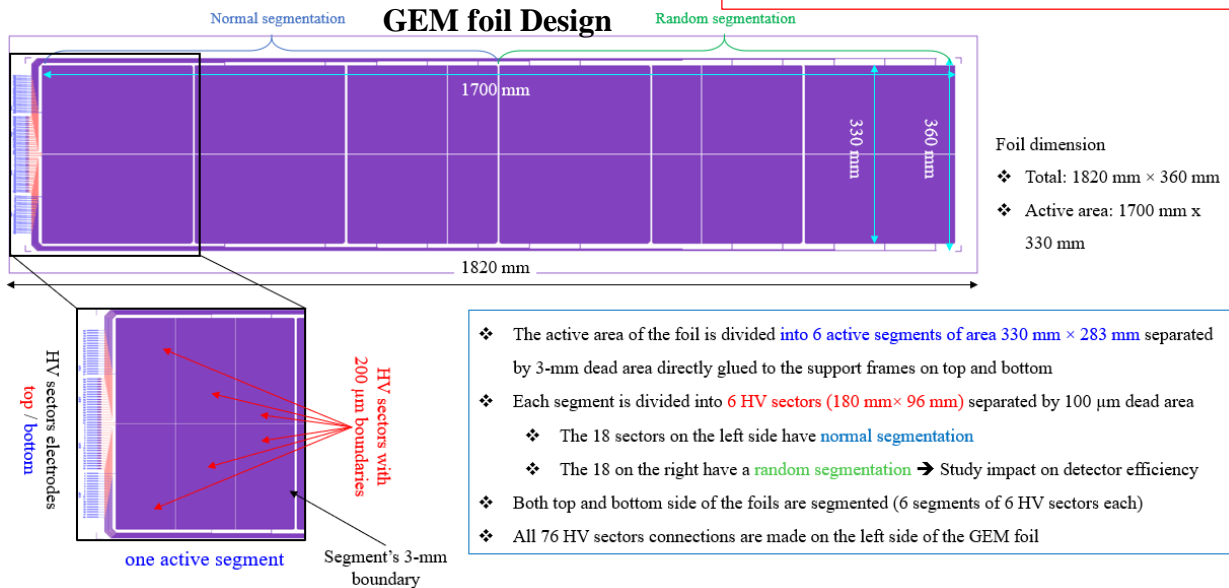
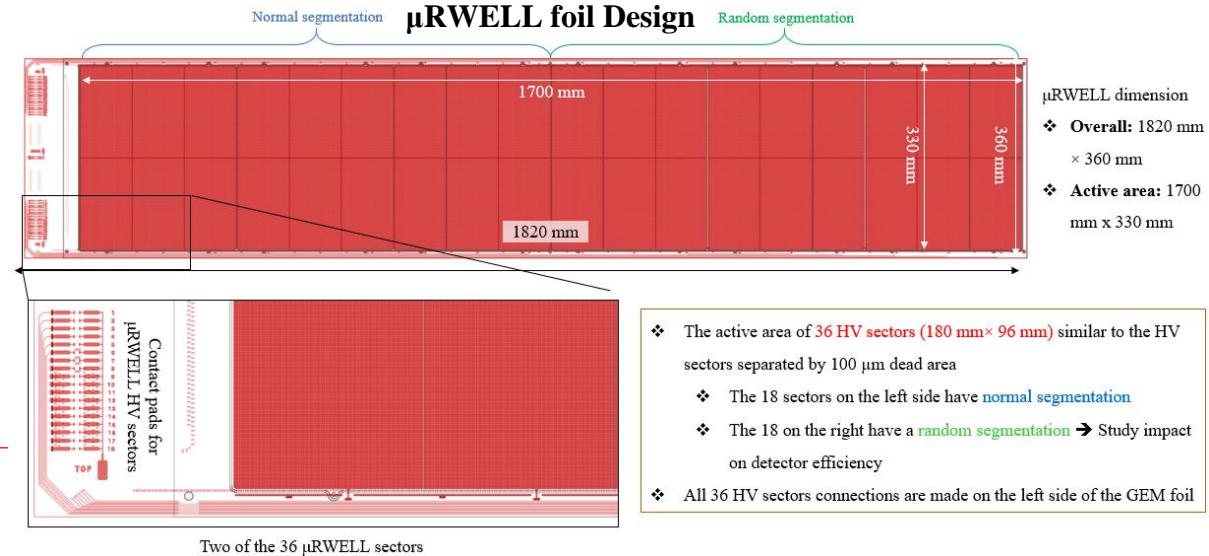

Capacitive-sharing U/V strip readout plane Design

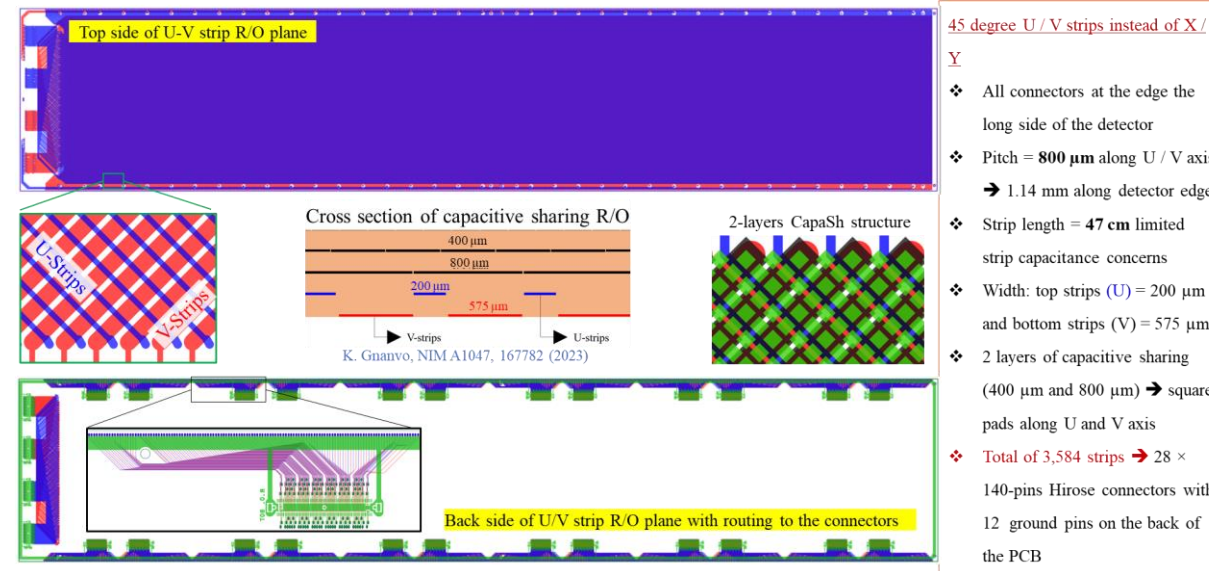

Adding **two MPGD Endcap Tracking (ECT) disks** both in the **hadronic** and in the **leptonic** regions increased the number of hits in the $|\eta| > 2$ region to improve pattern recognition.

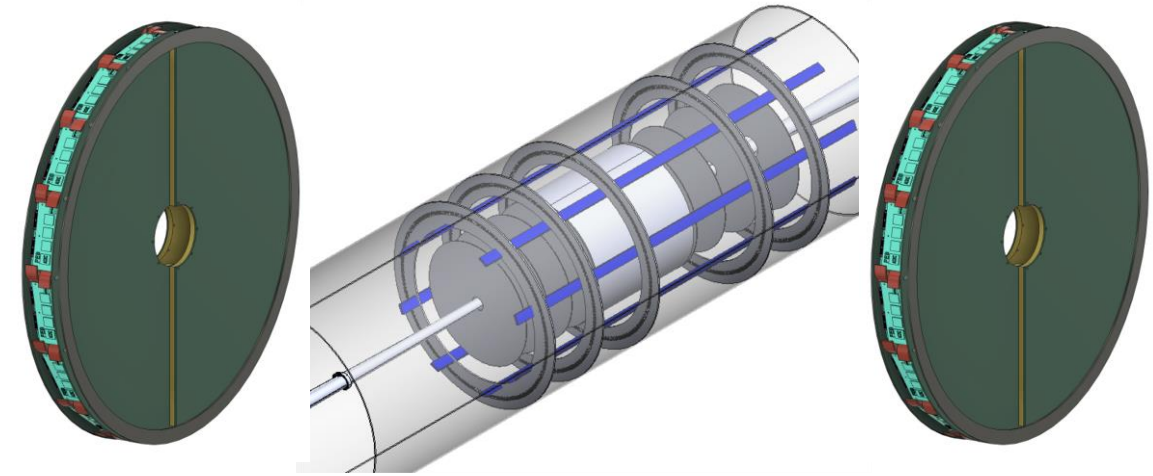
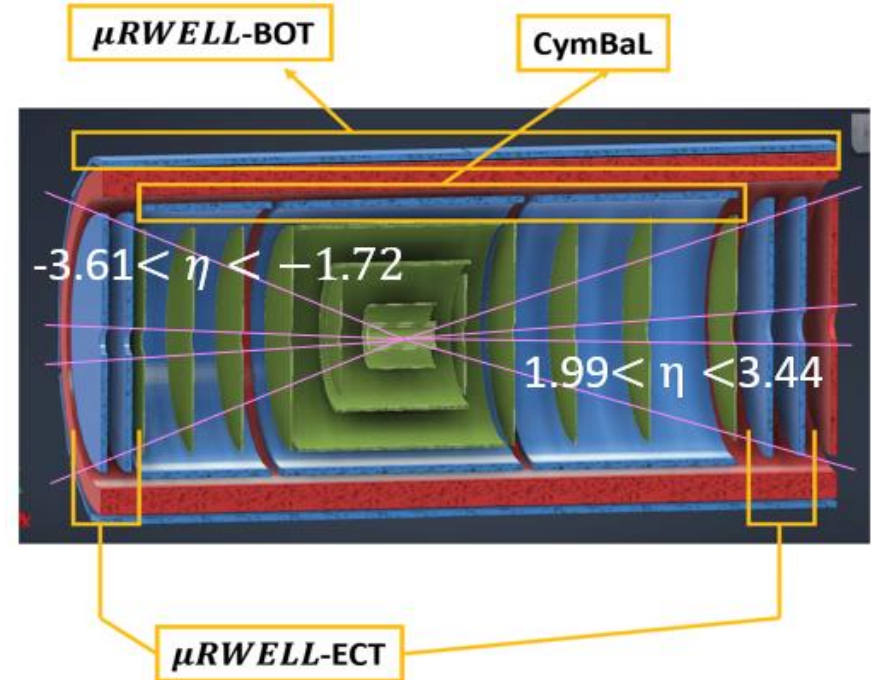

Lepton Disk (LD) μ RWELL-ECT

Hadron Disk (HD) μ RWELL-ECT

GEM- μ RWELL hybrid disks

- ❖ Double amplification with hybrid configuration
→ high gain $> 10^4$
- ❖ 2D strip read-out a la “COMPASS”
- ❖ 500 - 600 μ m pitch guarantees a spatial resolution better than 150 μ m
- ❖ time resolution ~ 10 ns

On-detector Front End Boards (FEBs)

- ❖ based on SALSA chips

MPGD Disk	Z Pos (cm)	Outer Radius (cm)	Outer Active Reg. radius (cm)	Calculated Beam pipes radii (cm)	Offset (mm)	Inner Radius (cm)	Inner Active Reg. radius (cm)
HD MPGD 2	163.5	50	45	5.58	22.5	9	10.5
HD MPGD 1	150.5	50	45	5.31	19.9	9	10.5
LD MPGD 1	-112.5	50	45	3.77	-3.1	4.5	6.0
LD MPGD 2	-122.5	50	45	3.92	-3.4	4.5	6.0

Standard gap GEM- μ RWELL hybrid Technology

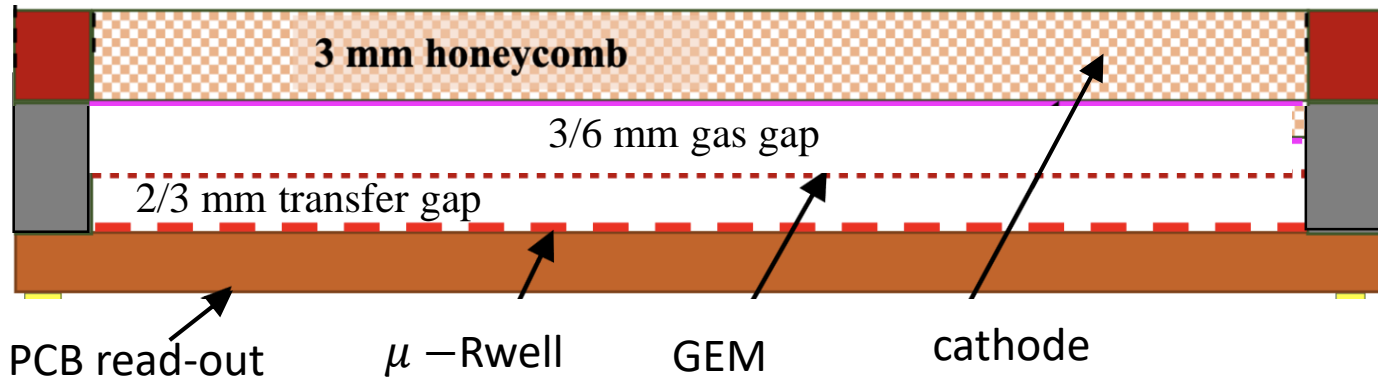

Combining the CC and μ TPC reconstruction (through a weighted average) a **resolution well below 100 μ m** could be reached over a wide incidence angle range.

CC= Charge Centroid

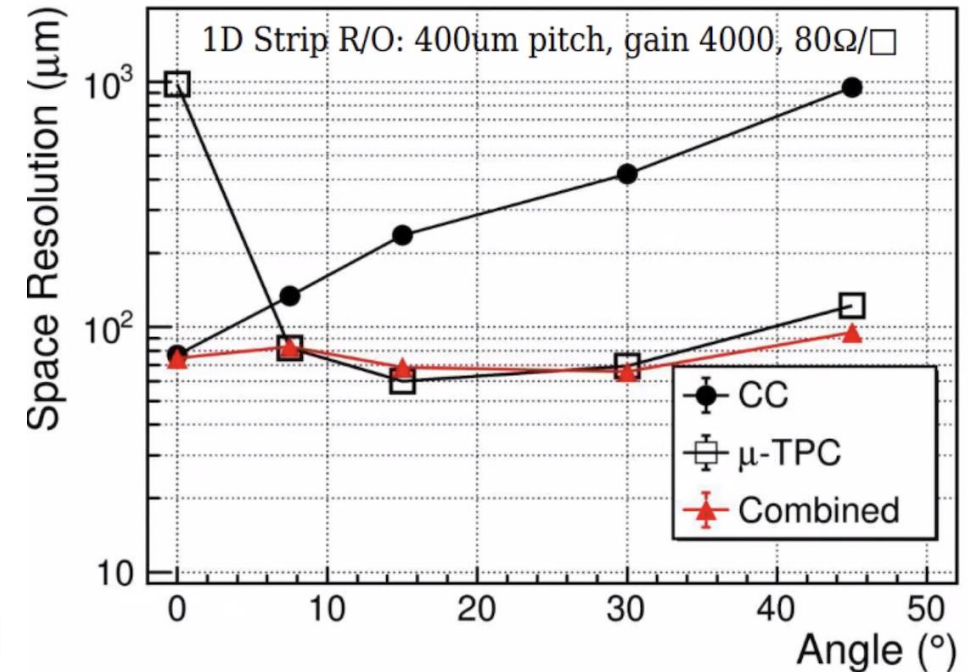
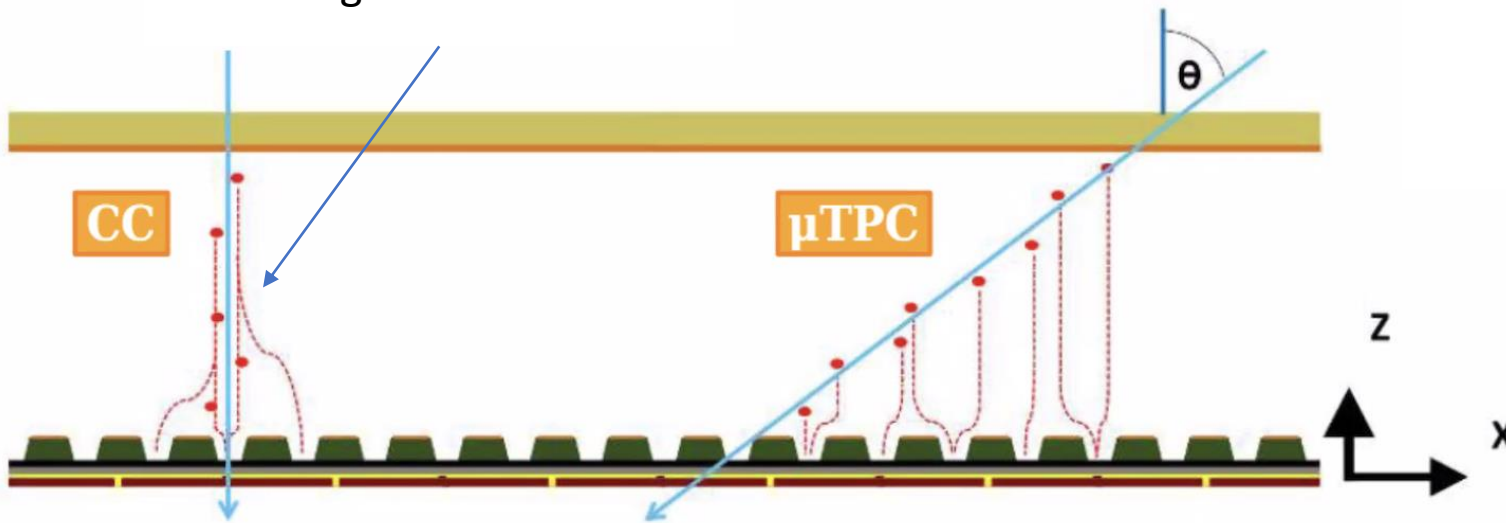

Ongoing test beam effort (Oct / Nov 2024)

- ❖ Reference Trackers: 2 Hybrid GEM- μ RWELL with 2D readout
- ❖ Detectors Under Test:
 - 2 Hybrid GEM- μ RWELL with 2D readout
 - 2 Groove with 2D readout

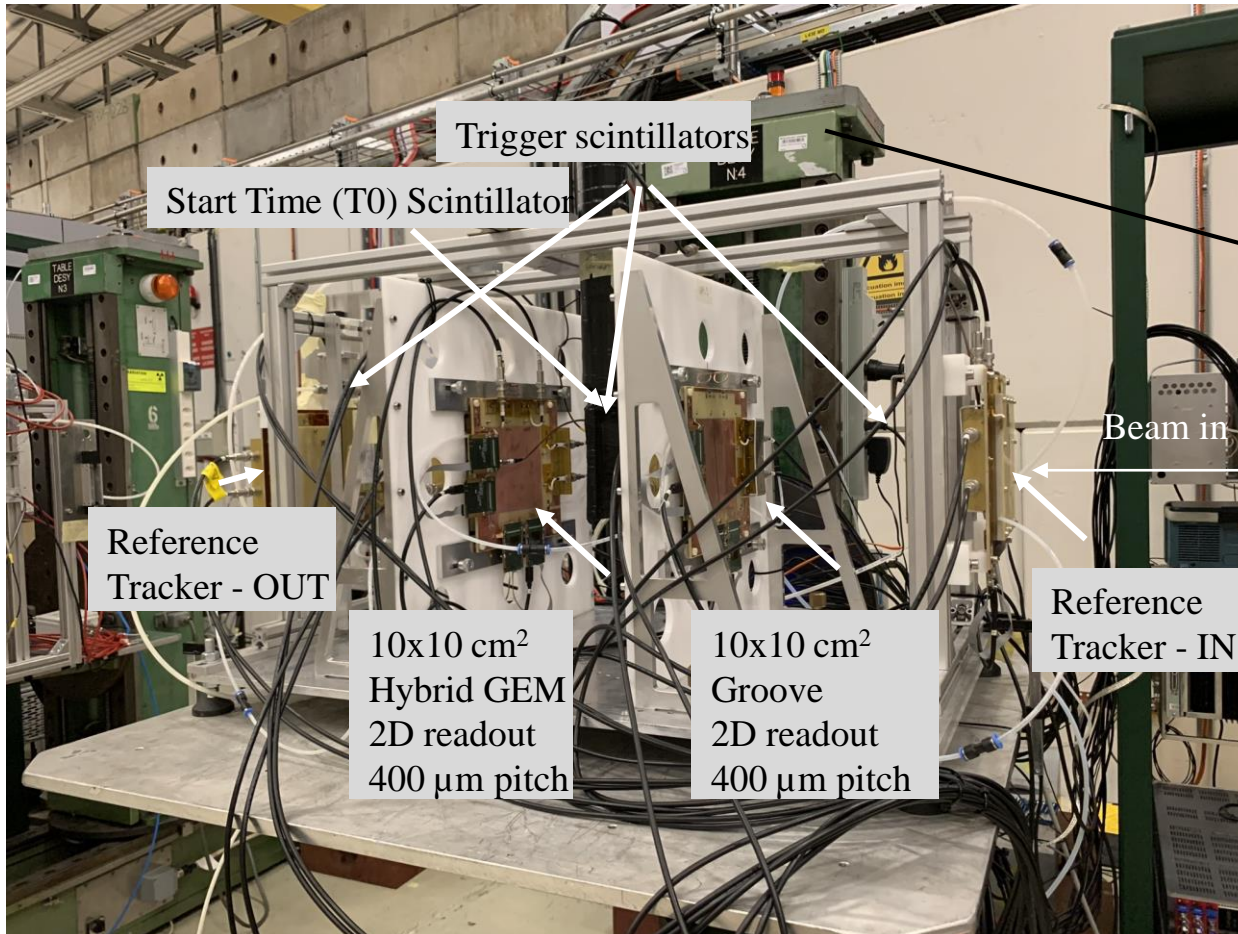
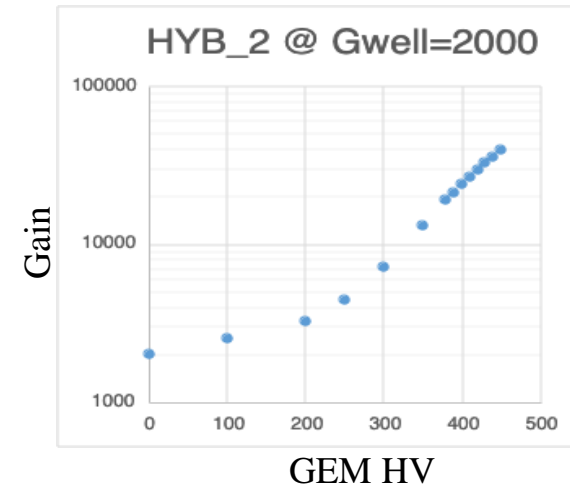

Detectors Under Test may be rotated to study resolution dependence for inclined tracks

SALSA: New ASIC for ePIC MPGD trackers designed and produced by the CEA Saclay / San Paulo groups

- **Channel features**
 - 4 dynamic ranges : 50 fC, 250 fC, 500 fC, 5 pC
 - 10 peaking times : from 50 ns to 500 ns
 - Support for high input capacitances up to 1 nF and beyond
 - Both signal polarities
 - Rate per channel : up to 100 kHz
 - Sampling rate : programmable, up to at least 50 MSPS
 - 12-bit ADC with >10-bit ENOB
- **Digital stage programmable features**
 - Pedestal equalization, common mode noise subtraction, zero suppression
 - Baseline tracking
 - Signal amplitude and timing extraction
- **Clock management with Prisme IP :**
 - Wide range jitter cleaner PLL, 4 clock frequency synthesizer, phase adjustment
- **Streaming and triggered readout**
 - Four 1 Gbit/s serial links
 - Non-ZS, signal shape or time-amplitude readout
- **Backend**
 - Traditional interface with separated clock, sync command and control ports
 - Innovative unified interface over 1 Gbit/s input link
- **Implementation**
 - 65 nm TSMC
 - 10-15 mW/ch @ 1.2V
 - Radiation hardened : SEU, > 300 Mrad, > 10^{13} n_{eq} / cm²

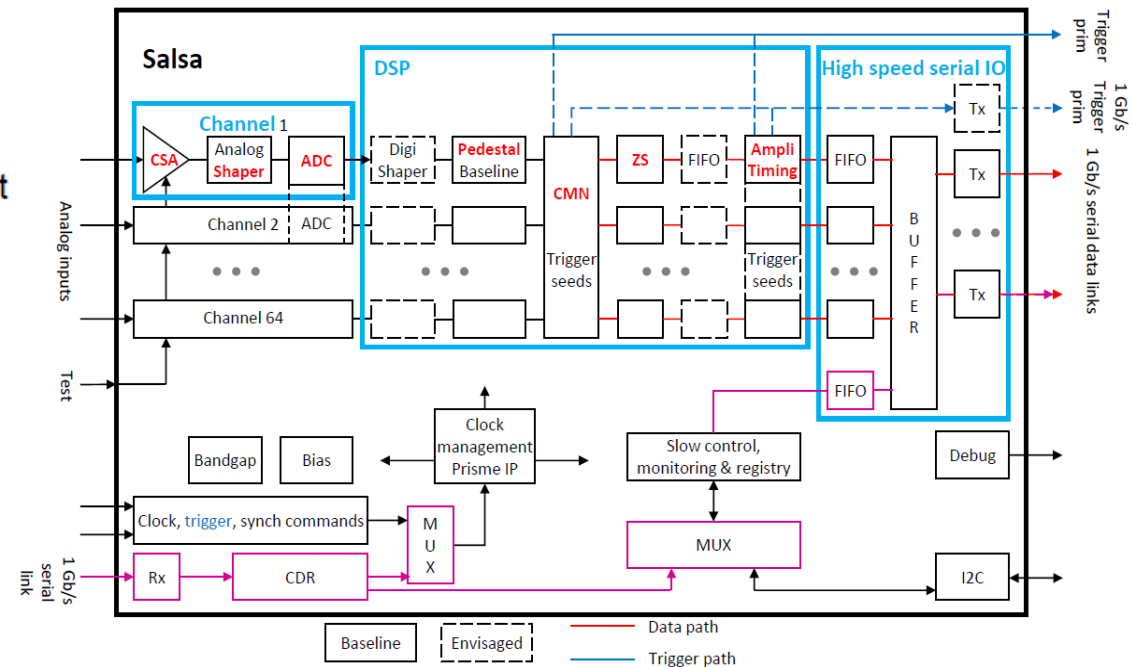
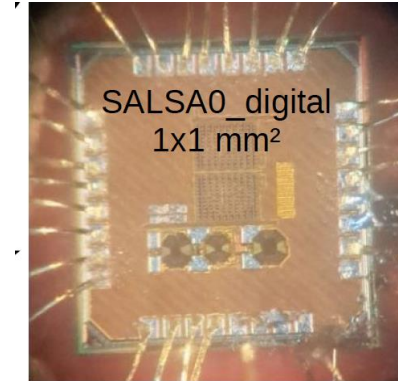

- ❖ MPGD tracking detectors in ePIC central region aim at complementing the Si trackers to provide
 - Fast timing (10 ns) for pattern recognition
 - additional space points ($< 150 \mu\text{m}$) for pattern recognition and help improve angular resolution at the hpDIRC level
- ❖ 3 MPGD subsystems in the ePIC Central tracking detectors:
 - CyMBAL and $\mu\text{RWELL-BOT}$ in the barrel regions
 - $\mu\text{RWELL-ECT}$ Disks in the end cap region
- ❖ R&D effort for ePIC MPGDs over the past years but is phasing down & replaced by project engineering design (PED) effort
- ❖ Development of engineering test articles (pre-production modules) for $\mu\text{RWELL-BOT}$ and $\mu\text{RWELL-ECT}$ modules is on track
- ❖ Readout electronics based on the SALSA ASIC under development at CEA Saclay / San Paolo for ePIC MPGD readout

Future looks bright and busy → Design → fabrication → test → commissioning → installation → operation

This material is based upon work supported by the U.S. Department of Energy, Office of Science, Office of Nuclear Physics under contracts DE- AC05-06OR23177

Back-up

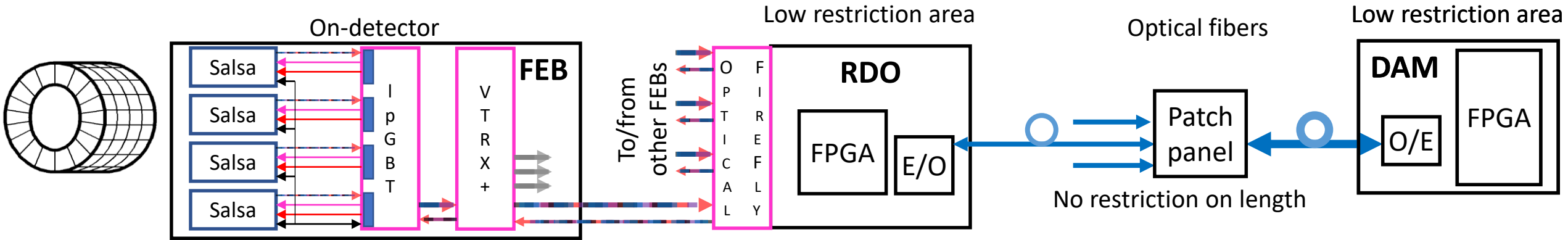

- **FEB** – frontend board with readout ASICs
 - Sub-detector specific
- **RDO** – readout module – first stage of FEB data aggregation, last stage to dispatch clock & control
 - Common design between sub-detectors, different form factor
- **DAM** – data aggregation module – interface with computing and global timing and control unit (GTU)
 - Common design for all sub-detectors
- Downstream towards detector : clock, control, monitoring
- Upstream towards storage : physics, calibration, monitoring data

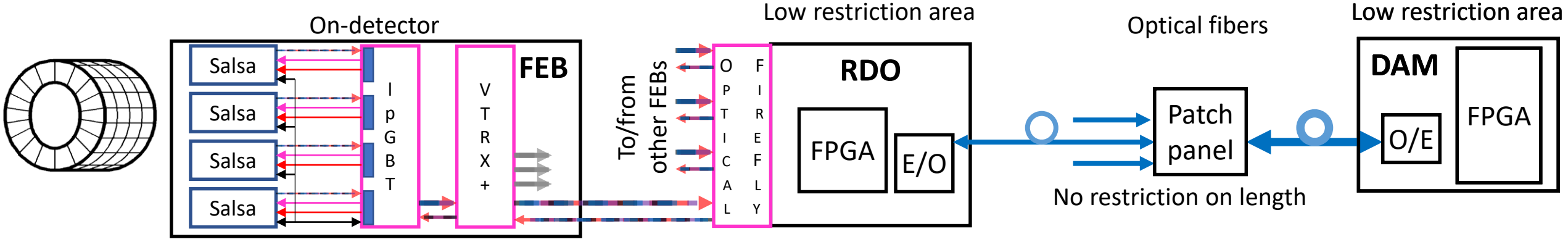

256-channel FEB: On-detector Front End Board (4 SALSA ASICs)

- ❖ SALSA receives recovered **clock** and **sync** data from an IpGBT eLink group
- ❖ SALSA sends **physics, calibration and monitoring** data to a number of IpGBT lines of the eLink group
- ❖ SALSA's are configured over daisy chained I2C interface from IpGBT
- ❖ IpGBT provide a bidirectional interface between 4 Salsas and remote FPGA on RDO
- ❖ VTRX+ is used with only one T_x line
- ❖ All ASICs are radiation hard

1024-channel RDO : common hardware with adaptation based on FireFly transceivers from Samtec

- ❖ Single 4-lane bidirectional FireFly is enough to serve 4 FEBs
 - Placed anywhere in user friendly area
- ❖ No particular restrictions on power consumption, cooling infrastructure, radiation, magnetic field