



# Design and construction of a novel energy-loss optical scintillation system (ELOSS) for heavy-ion particle identification

Marco Cortesi<sup>1</sup>, Sean Dziubinski<sup>1,2</sup>, Alexandra Gade<sup>1,2</sup>, Steve Lidia<sup>1</sup>, Remco Zegers<sup>1,2</sup>, Daniel Bazin<sup>1,2</sup>, Jorge Pereira<sup>1</sup>, Iulia-Maria Harca<sup>1</sup>, Lucas Rakieten<sup>1</sup>

<sup>1</sup> Facility for Rare Isotope Beams, Michigan State University, East Lansing, MI 48824, USA

<sup>2</sup> Dep. of Physics and Astronomy, Michigan State University, East Lansing, MI 48824, USA



U.S. DEPARTMENT OF  
**ENERGY**

Office of  
Science

# Facility For Rare Isotope Beams (FRIB)

- FRIB is a US DOE Office of Science scientific user facility (one of 28) intended to provide beams of rare isotopes – located on MSU campus
- FRIB started in 2008 and reached the last project milestone in January 2022, five months ahead of schedule and on budget
- Experiments began in May 2022. FRIB is open to researchers from around the world based on scientific merit – Program committee approximately once per year



Facility for Rare Isotope Beams  
U.S. Department of Energy Office of Science | Michigan State University  
640 South Shaw Lane • East Lansing, MI 48824, USA  
frib.msu.edu

M. Cortesi, CPAD 2024, 19 November 2024

# Key FRIB Features that Enable Discovery

- FRIB's key feature is 400 kW beam power
  - 8 pμA or  $5 \times 10^{13}$   $^{238}\text{U}$  /s
  - 42 pμA or  $2.6 \times 10^{14}$   $^{48}\text{Ca}$  /s
- Experiments with fast (200 MeV/u), stopped (trapped), and reaccelerated beams (0.6 to 10 MeV/u)
- Separation of isotopes in-flight provides
  - Fast development time for any isotope
  - Beams of all elements and short half-lives
- Isotope harvesting capability from beam dump water

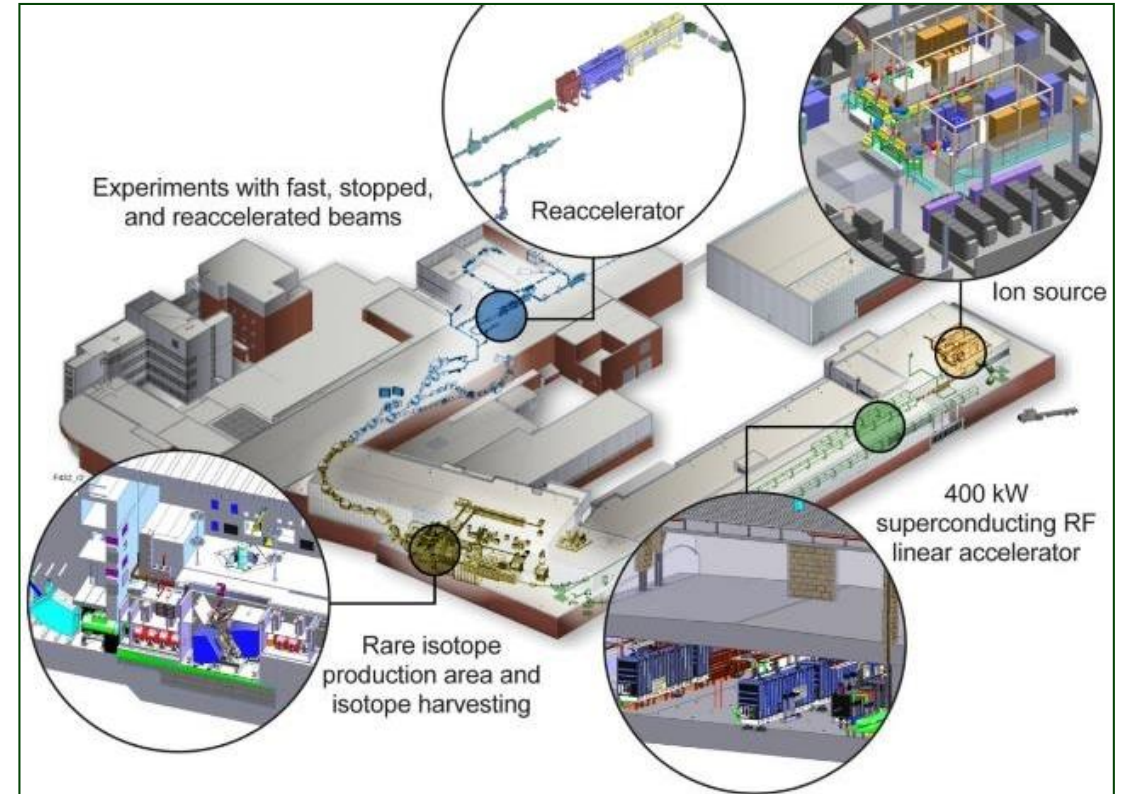

# The S800: a high-resolution, high-acceptance spectrograph

## Analysis Line

- Total length: 22 m with three diagnostics stations: OBJ, IIM, TAR
- Five quad triplets + four 22-deg dipoles
- **Two ion-optics modes:**
  - » Focus (F): achromatic OBJ - TAR
  - » Dispersion Matched (DM): dispersive OBJ - TAR ( $D \approx 11 \text{ cm}/\%$ )
- **Momentum acceptance:**
  - »  $\pm 2\%$  Focus (F)
  - »  $\pm 0.5\%$  Dispersion-Matched (DM)

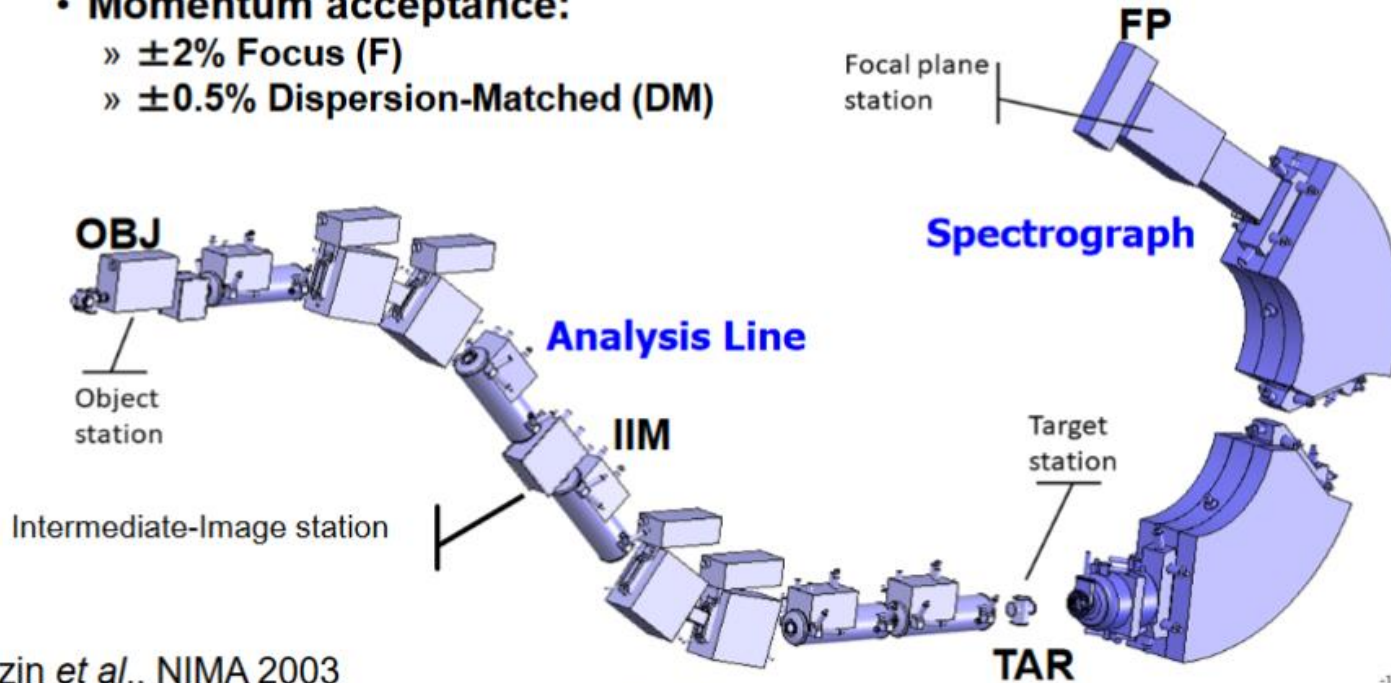

## Spectrograph

- Total length: 18 m with one diagnostics station: FP
- Two quadrupoles + two 45-deg dipoles
  - » No high-order elements
  - » Aberrations are corrected analytically using measured field maps
- **Acceptance:**
  - » **Momentum:  $\pm 2.5\%$**
  - » **Solid-angle: 20 msr**
- **Resolution:**
  - » **Angular: 2 msr**
  - » **Momentum: 0.1% (F) / 0.01% (DM)**

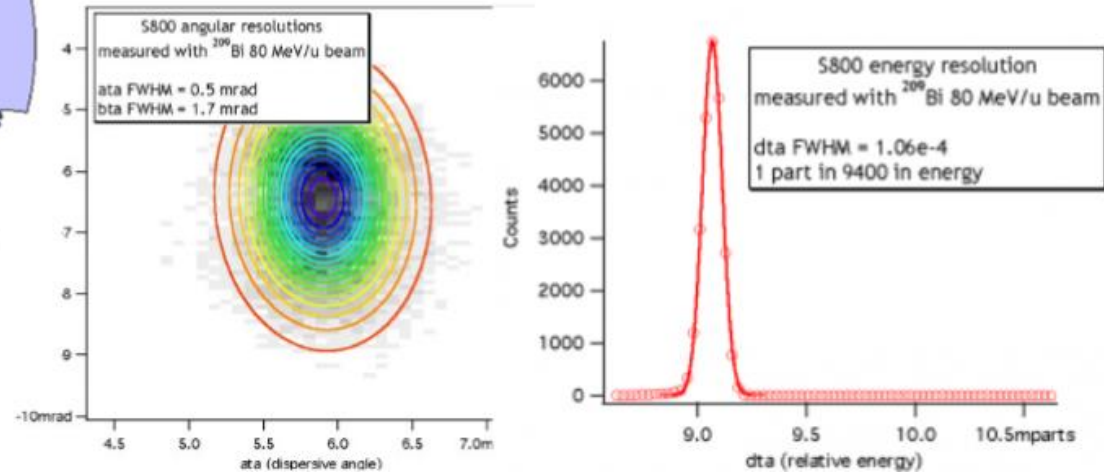

Bazin *et al.*, NIMA 2003

S800 Wiki (<https://wikihost.nslc.msu.edu/S800Doc>)



# S800 spectrometer: PID at the focal-plane

Reaction target  
100-400mg/cm<sup>2</sup>

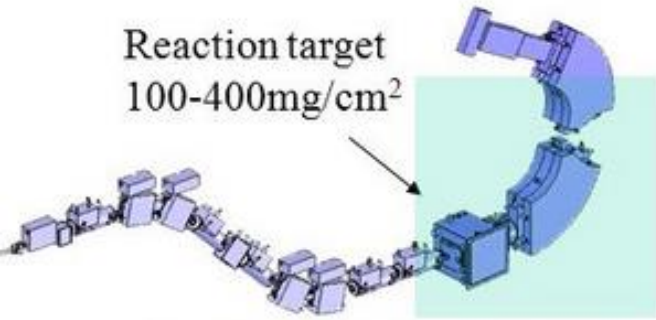

Reaction product identification  
S800 spectrograph

PID: Bp-dE-ToF

$$Z \sim \sqrt{\Delta E \cdot \beta^2} \rightarrow f(\Delta E, ToF)$$

$$\frac{A}{Q} = \frac{e B \rho}{uc \beta \gamma} \rightarrow f(x, ToF)$$

$$Q = A \frac{uc \beta \gamma}{e B \rho} \rightarrow f(TKE, x, ToF)$$

Focal Plane detector system for heavy-ion PID

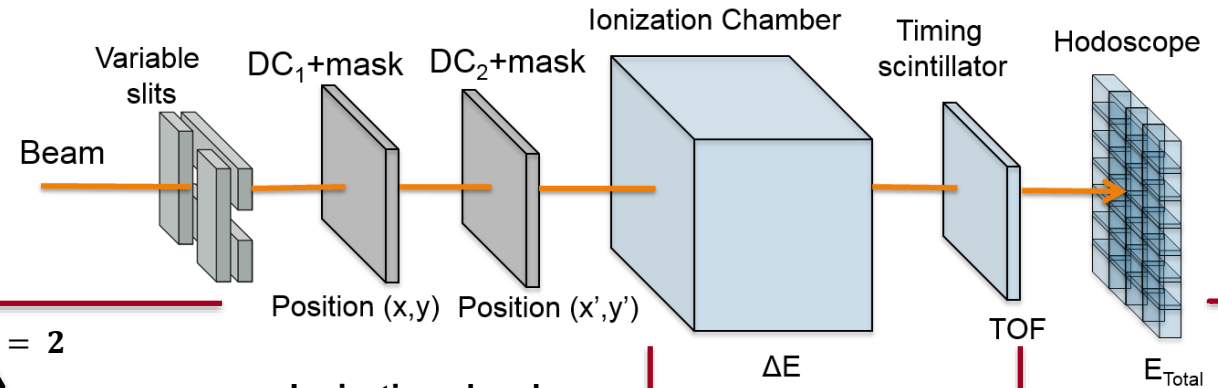

## Cathode Readout Drift Chamber (CRDC):

Position and angles  
2 x CRDCs (30x60cm<sup>2</sup>), 1m apart, filled with 40 Torr CF<sub>4</sub>(20%)+C<sub>4</sub>H<sub>10</sub>

- Slow detector, Rate < 5kHz
- Poor position resolution > 1mm
- Aging problems

Energy loss (arb. units)

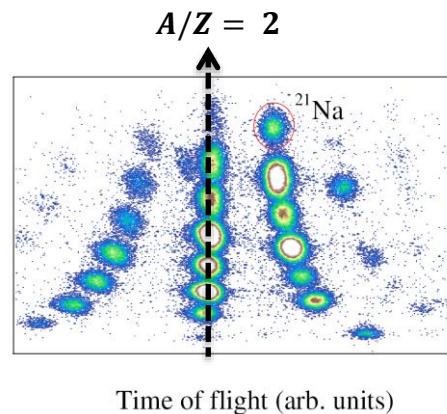

## Ionization chamber:

- $\Delta E/E$
- 32 fragile thin foils
  - Energy resolution  $\Delta E/E \approx 1.2\%$  ( $A \approx 100$ )

## Plastic Scintillator:

- Time resolution ~450ps

## Hodoscope:

- Hydrscopic CsI crystals
- TKE resolution 0.85%

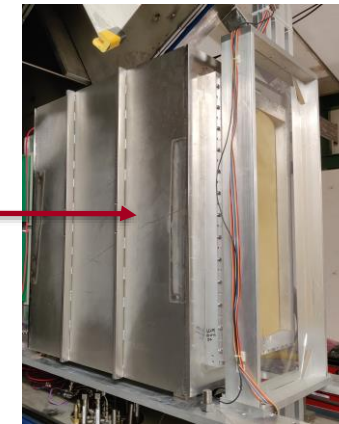

Improve  $\Delta E/E$  needed to explore new regions of the nuclear chart for nuclear structure and nuclear astrophysical studies → heavy beams (up to U) expected from FRIB!

# Parallel-plate Ionization Chamber (IC) for $\Delta E$ measurement

- Present system for Z identification based on  $\Delta E$  measurement based on parallel-plate IC
  - 16 stacked parallel-plate IC (each 1" long) filled with P10 (300-600 Torr)
  - Bias optimized to 80 Volt/cm.
- Performance
  - » Rate capability < 6 kHz (limited by signals pile up)
  - » Large plate capacitance  $\rightarrow$  low Signal-to-noise
  - » Good energy resolution ( $\sim 1.2\%$  sigma) for  $Z < 50$

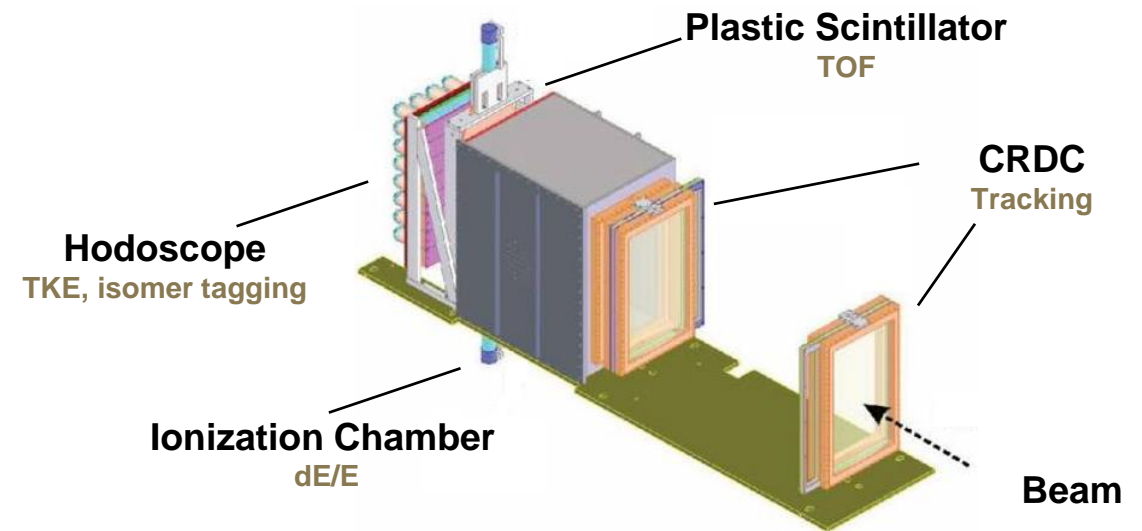

Cerizza G. et al, Phys. Rev. C 88, 051301(R) (2013).

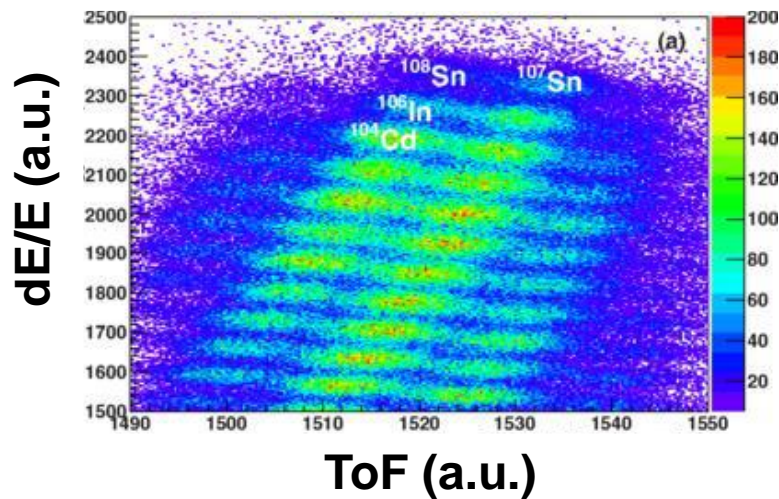

# New Concept: Energy-Loss Optical Scintillator System

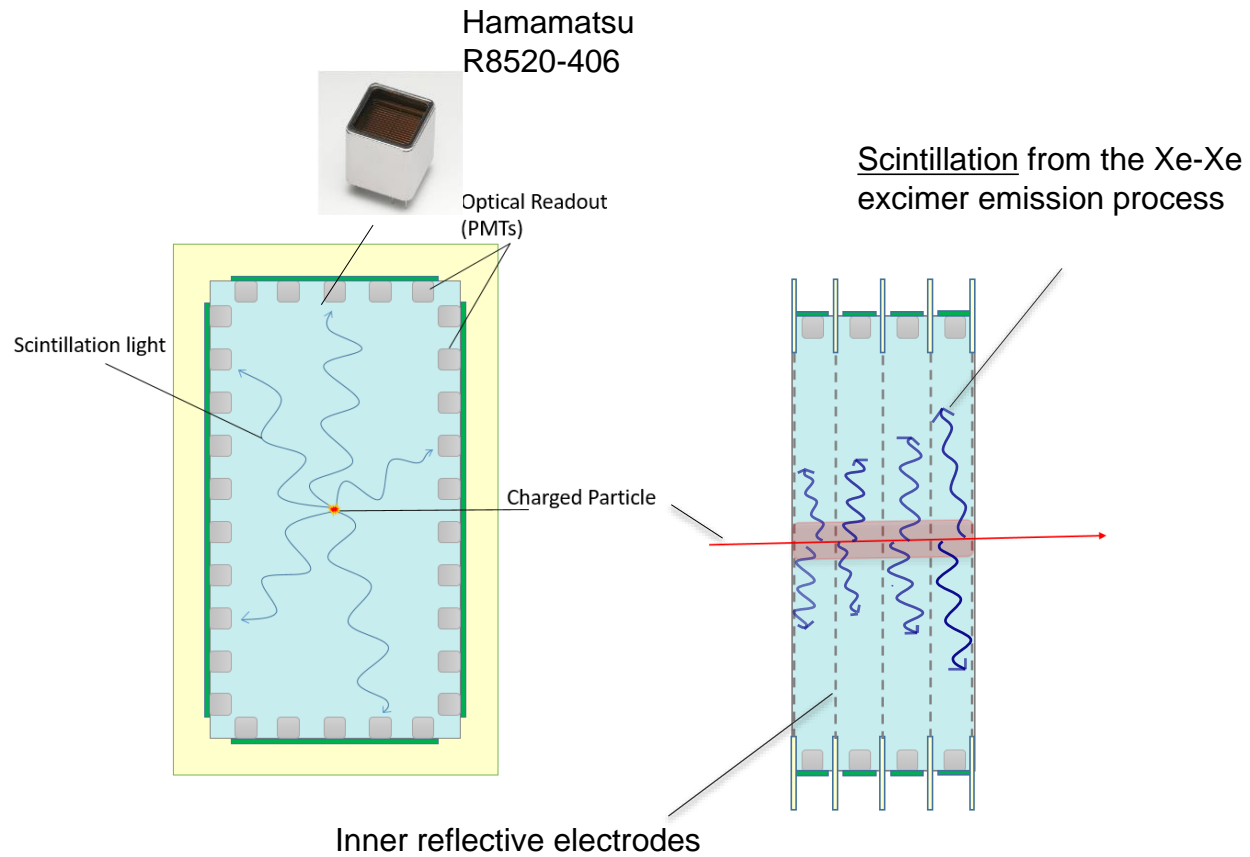

## Operational principle:

- ) Large volume filled with high-scintillation yield gas (Xe)
- ) Excitation created along the track of a charged particle that crosses the volume
- ) De-excitation with emission of intense, prompt scintillation light
  - \*) *Optionally: stimulated emission of electro-luminescence light*
- ) The light readout by array of photodetectors that surround the detector effective volume

## -) dE/E based on Xe scintillation light detection

- ) High scintillation yield → 28 photons/keV - 70% of NaI(Tl)
- ) Fast process → scintillation photons emitted within a few ten nsec
- ) Homogeneous medium, no radiation damage
- ) Compact and flexible geometry
- ) Scintillation light detection based on well-developed technology
  - single-electron sensitivity with 30% quantum efficiency
  - time resolution < 100 ps
- ) Easy purification and high efficiency gas recovery technique
- ) Readout decoupled from the sensitive medium → high SNR

## -) Optical readout configurations

- ) Array of Hamamatsu PMTs (120 units) model R8520

## -) Commercially available DAQ

- ) Based on QDC-MDPP-32 for PMT-based readout

Work supported by the NSF-MRI grant: PHY-2017986



# ELOSS Optical Readout: R8520-PMT arrays

- Geometry: array of Hamamatsu PMTs (model R8520-406) in a chess-like board configuration

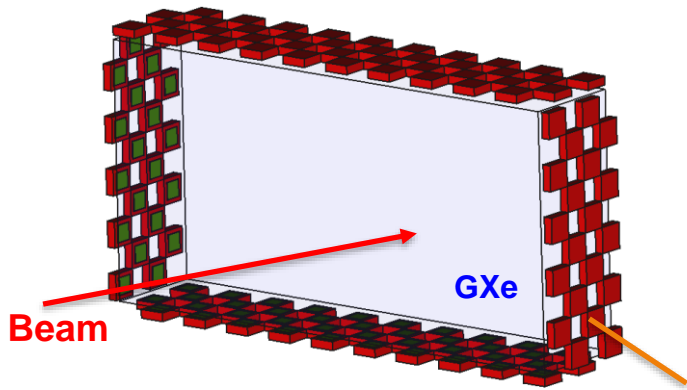

Dimension 30mm x 30mm  
Effec. Area 20.5mm x 20.5mm



Parameter	R8520-406			R8520-506			Unit	
	Min.	Typ.	Max.	Min.	Typ.	Max.		
Cathode sensitivity	Luminous (2856 K)	80	100	—	80	100	μA/lm	
	Blue sensitivity index (CS 5-58)	—	11.0	—	—	9.5	—	
	Radiant at 420 nm	—	100	—	—	80	mA/W	
	Quantum efficiency at 175 nm	—	30	—	—	3	%	
	Quantum efficiency at 420 nm	—	25	—	—	25	%	
Anode sensitivity	Luminous (2856 K)	40	100	—	40	100	A/W	
	Gain	—	1 × 10 <sup>6</sup>	—	—	1 × 10 <sup>6</sup>	—	
Anode dark current (After 30 minute storage in darkness)		—	2	20	—	2	20	nA
Time response	Anode pulse rise time	—	1.8	—	—	1.8	—	ns
	Electron transit time	—	12.4	—	—	12.4	—	ns
	Transit time spread (FWHM)	—	0.8	—	—	0.8	—	ns
Pulse linearity (2 % deviation)		—	30	—	—	30	—	mA

R8520

## Optical readout configuration

- ) 4 sectors (50 mm wide) → 30 PMTs arrange in 4 arrays (two per coordinate)
- ) Effective volume width = 200 mm; total detector width (along the beam) = 300 mm
- ) 5 inner /reflector/electrodes foils (two at ground and two at +HV)
- ) 120 PMTs mounted on vertical and horizontal supporting PCB hosting the voltage-divider circuit

## Data output:

- ) Amplitude light signal → sum form all the PMT
- ) ToF → average timing from PMTs of each sectors
- ) Localization → light distribution center of the gravity

<sup>34</sup>Se<sup>82</sup> (140 MeV/u)  
Impinging charged particle

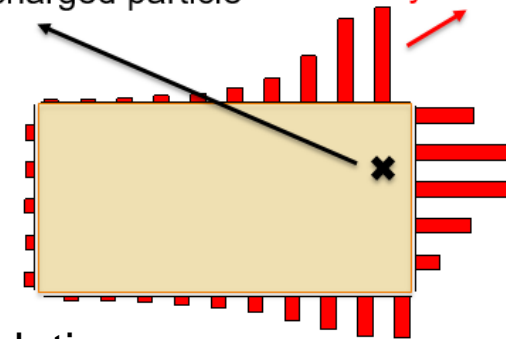

GEANT4 Simulation



# Mechanical Design and Fabrication

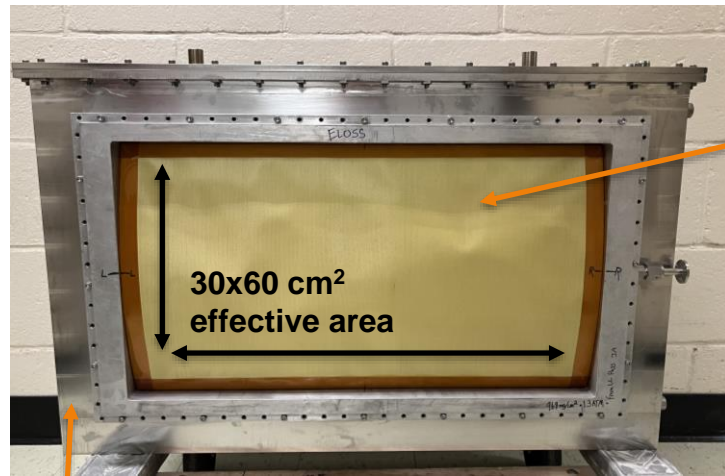

Kevlar-reinforced Dyneema pressure window  
-) Thickness <math>< 20 \text{ mg/cm}^2</math>  
-) Rate for 1.3 atm  $\Delta P$

Stainless steel detector vessel

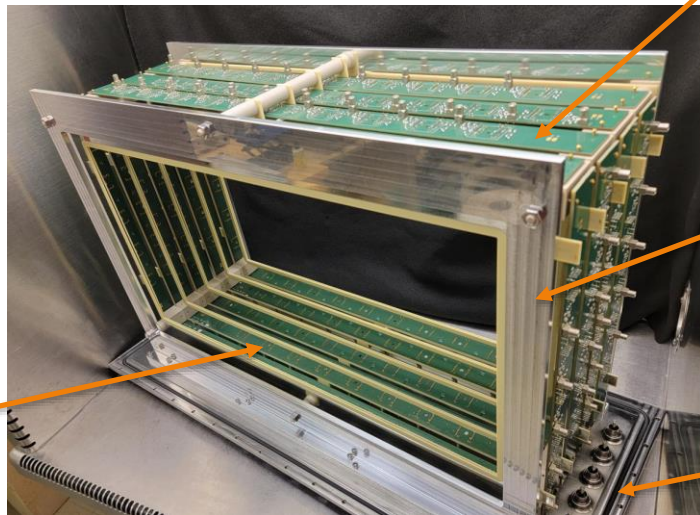

Voltage-divider PCB

Support (Al) for the reflective electrode foils and optical readout

Electrode foils PCB frame

Stainless steel lid with all electrical feedthroughs

## Gas Handling System

- Fill/evacuate ELOSS vessel
- Operate in sealed mode with a pressure range 400-800 Torr

## Gas Purification System

- GHS flows pure Xe through GPS continuously (reduce impurities  $\rightarrow$  high scintillation yield)

## Cryogenic Gas Recovery System

- Recovers  $\sim 99\%$  of Xe gas



LN<sub>2</sub> Dewar

# Optical Readout and interfaces

## S800 Focal-Plane Box

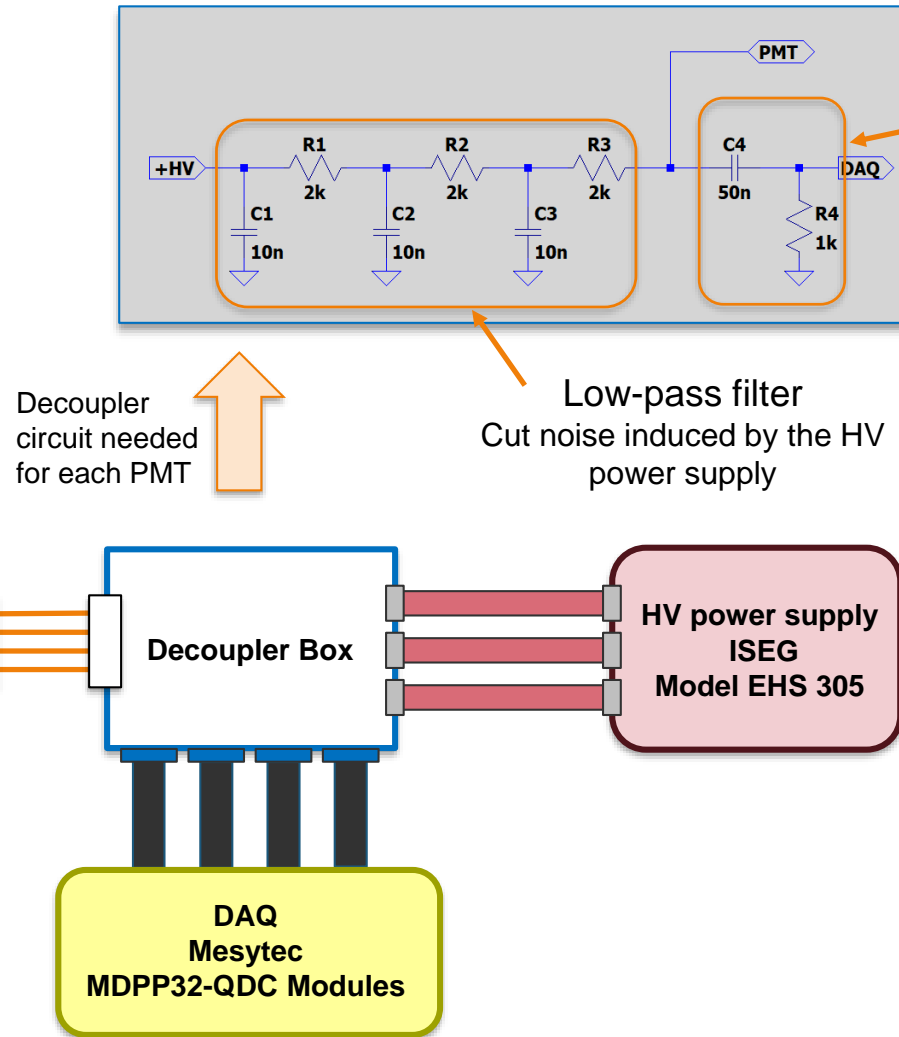
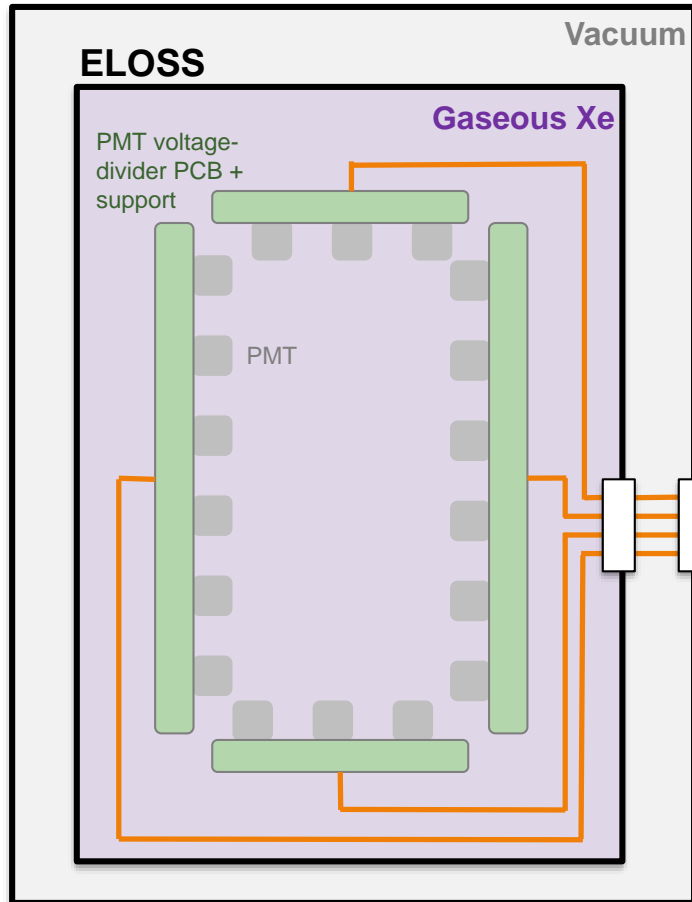

- **120 Hamamatsu R8520-406 PMTs**
  - Positively biased anode around +800 V
- **Reflective electrode foils**
  - Stimulated electroluminescence
    - » 2<sup>nd</sup> and 4<sup>th</sup> foil >4 kV
    - » 1<sup>st</sup>, 3<sup>rd</sup>, and 5<sup>th</sup> are grounded through pre-amplifier
- **External Decoupler Circuit**
  - Reduces # of cables/feedthroughs in focal plane box (PandaX)

X. Chao et al., *Scien. China Phys., Mech. & Astron.* **57**, 1476 (2014).

# Energy-loss reconstruction

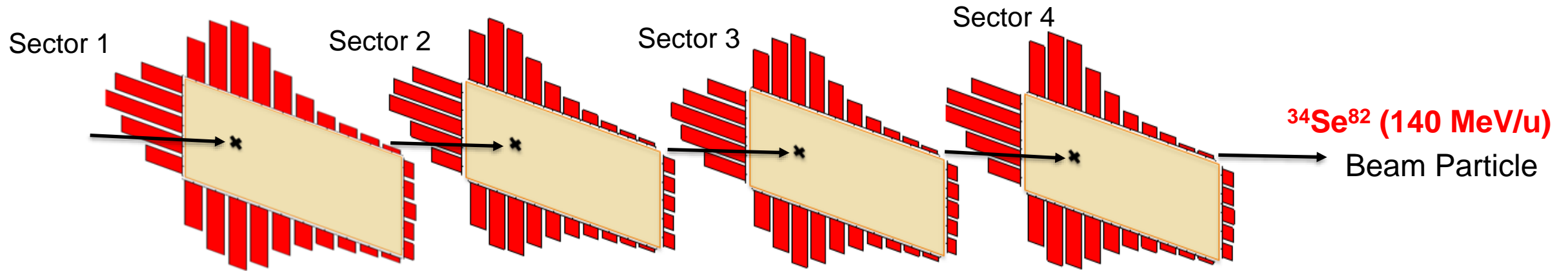

-) The total amount of light is calculated from the sum of photons measured in all the four sectors.

$$\sum_{i=1}^{120} \underbrace{\Delta E(Z) * Y_{Xe} * \epsilon_i(x, y, \Omega_i)}_{\text{Light collected by each PMT (\# of photons)}} * \underbrace{PDE_i}_{\text{Photon detection efficiency}} * \underbrace{Gain_i}_{\text{PMT Gain (V}_{\text{PMT}})}} * e = Q_{total}(x,y) \propto Z$$

The photon collection efficiency ( $\epsilon_{ph}$ ) depends on the solid angles seen by the individual PMTs and changes across the ELOSS effective area  
 → need correction by mapping  $\epsilon(x,y)$

$$\text{PMT Anode sensitivity} \Rightarrow \zeta_i = PDE_i * Gain_i$$

# Photon collection efficiency and PMTs calibration

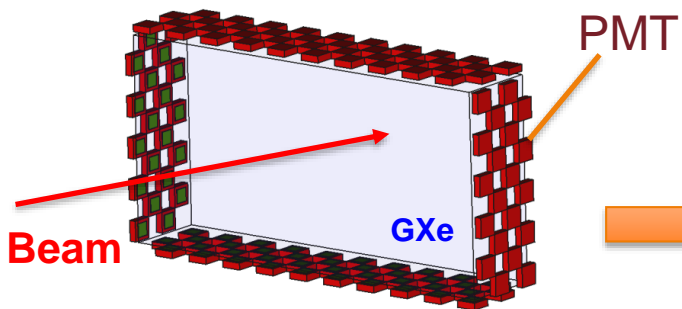

Monte Carlo simulation of  $^{118}\text{Sn}$  @ 100 MeV/u in 600 Torr ELOSS with uniform PMT sensitivity

Simulate beam impinging on the full area →  
Total # of detected photons as a function of X,Y

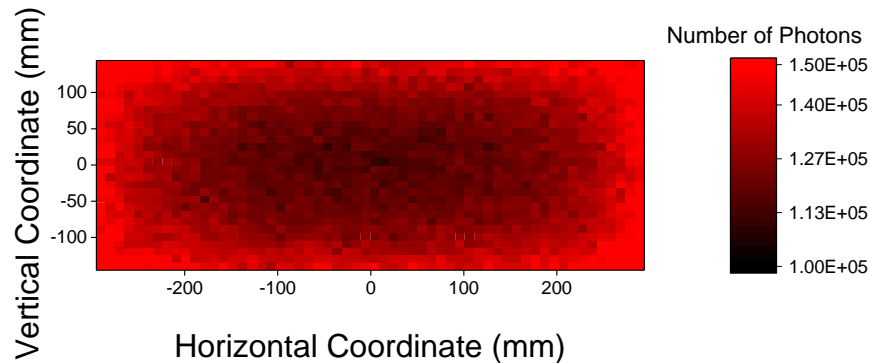

Distribution of detected photons with beam distributed along a narrow strip on the dispersive beam coordinate

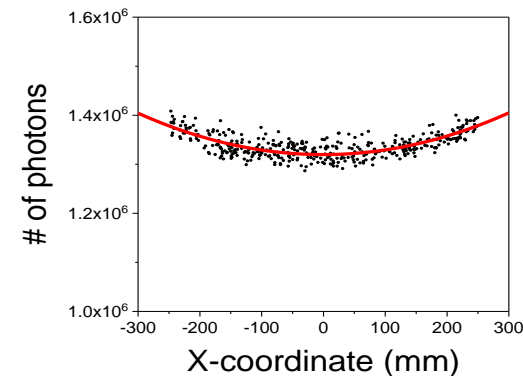

## Correction procedure:

### ■ Goal:

- Calculate a correction factor based on position of impinging particle

### ■ Procedure:

- Calibrate PMTs to uniform sensitivity  
Preserve time response
- Scan ELOSS effective area with beam to measure energy loss by x-y particle position

Hamamatsu R8520 Anode sensitivity variations

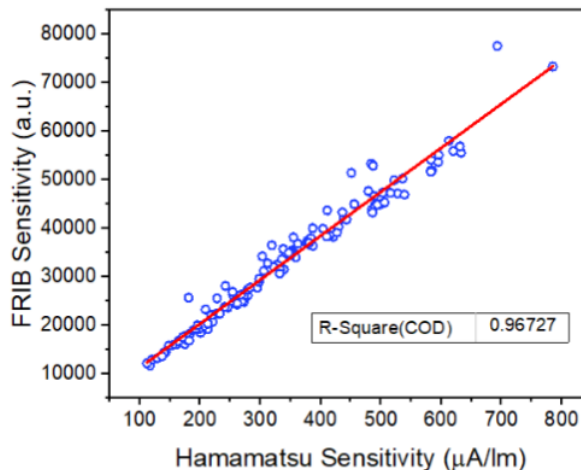

Difference in the PMTs anode sensitivity by factor 10!

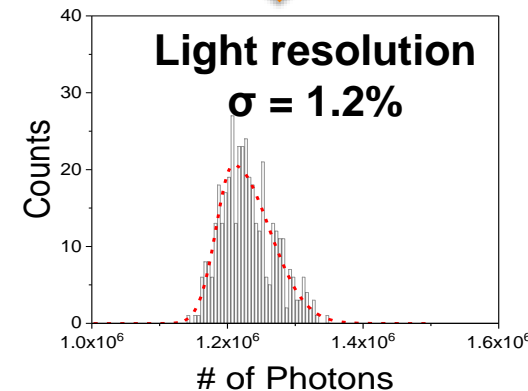

# PMT anode sensitivity calibration

A dedicated system (to be used with all the PMT) for measuring light emitted by a LED under fixed and know conditions (same voltage-divider, same Voltage bias, same LED, same electronics, etc.)

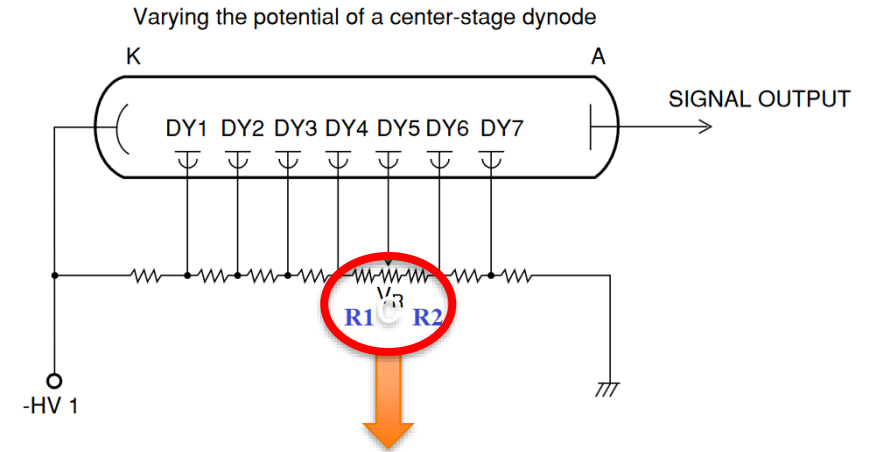
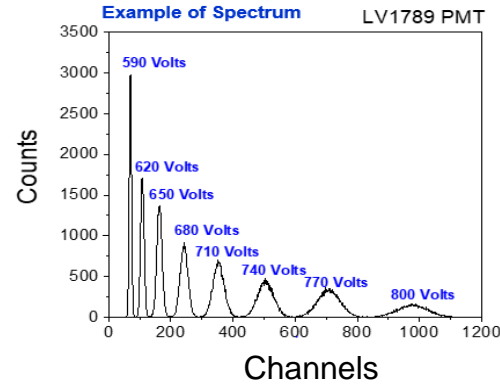
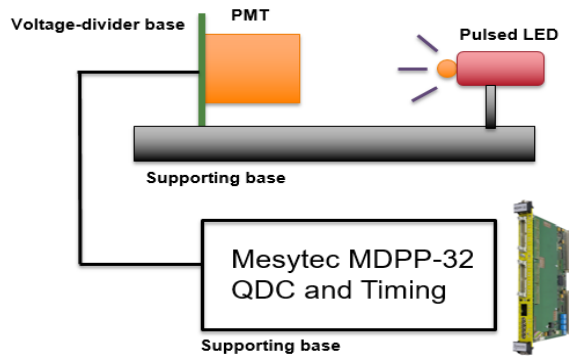

After calibration ( $V_{PMT} = 800V \pm 10\%$ )

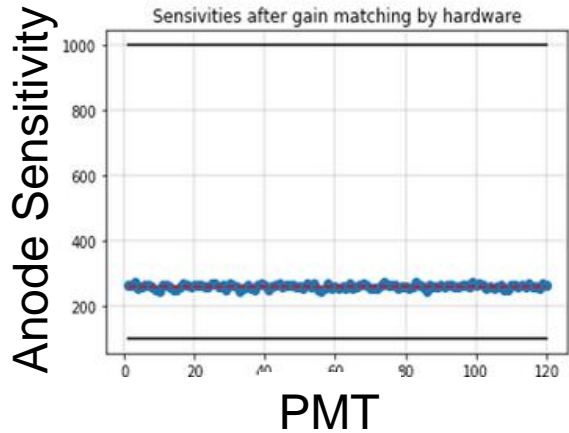

Before calibration ( $V_{PMT} = 800V$ )

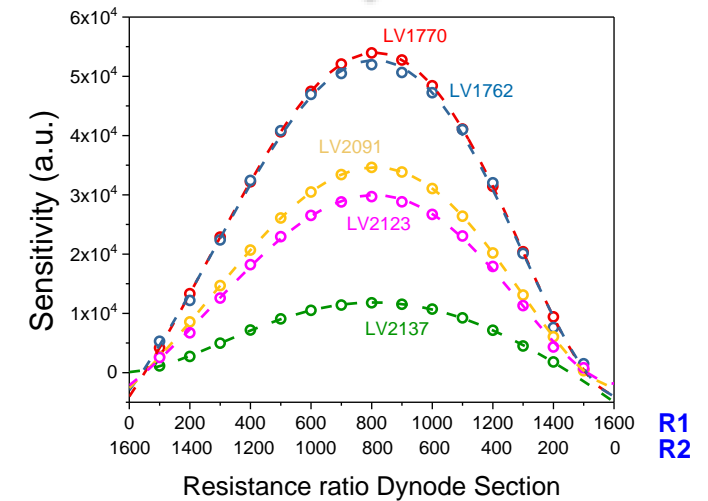
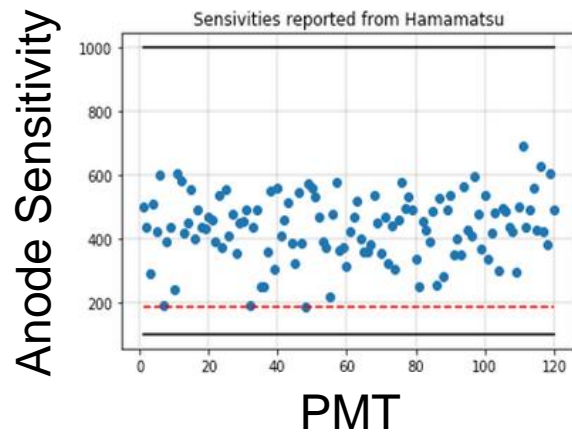

# Correction for the variation of $\varepsilon_C$ across the effective area

Mapping of the photon collection efficiency extracted from an uniform irradiation of the entire area

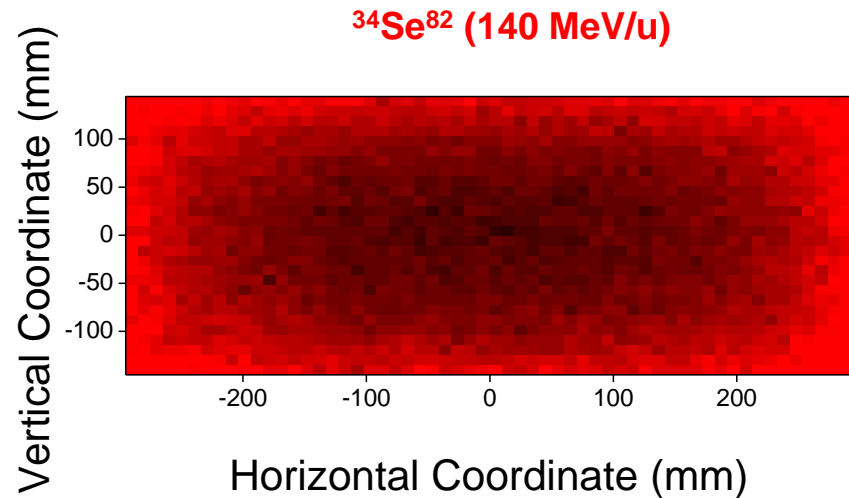

Calculation of the correction factor:

Step 1: Normalize the 2D distribution  $\varepsilon_C$  of to the minimum value  $\rightarrow \tilde{\varepsilon}_C$

Step 2: Fit the distribution  $\tilde{\varepsilon}_C$  with a 9<sup>th</sup> degree polynomial function in two variable (x,y)

$$\tilde{\varepsilon}_C(x,y) = \sum_{i,j=0}^6 k_{x_i y_j} x^i y^j$$

Step 3: Calculate the correction factor  $C(x,y)$  as

$$C(x,y) = (\tilde{\varepsilon}_C(x,y))^{-1} = \left( \sum_{i,j=0}^6 k_{x_i y_j} x^i y^j \right)^{-1}$$

$$L(Z) = M(x, y, Z) * C(x,y)$$

Corrected light value  $\leftarrow$   $\rightarrow$  Measured scintillation light

To calculate  $C(x,y)$ , the particle position still needs to be reconstructed!  
 $\rightarrow$  Neural network based data processing for localization

# Deep Neural Network for localization capability

$$L(Z) = M_1(x_1, y_1, Z) * C_1(x_1, y_1) + \dots + M_4(x_4, y_4, Z) * C_4(x_4, y_4)$$

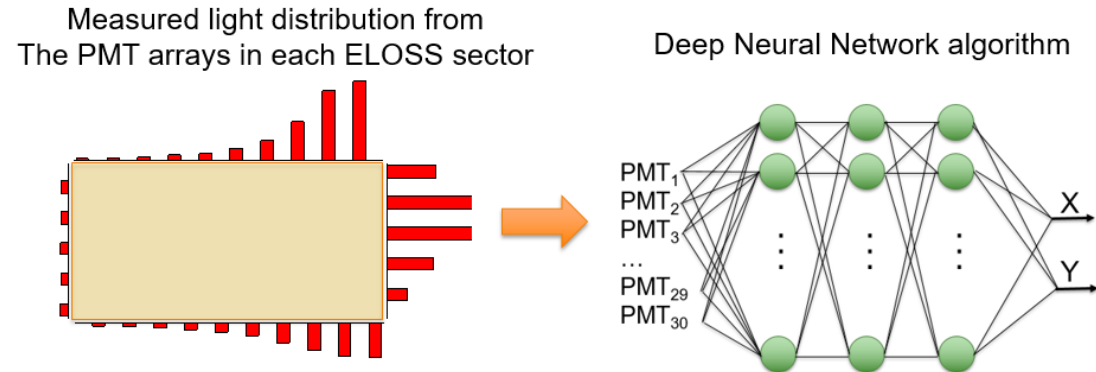

Position of the impinging particle

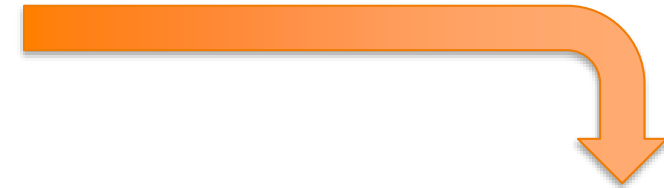
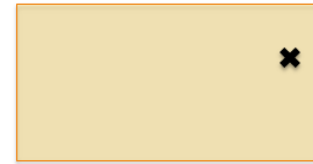

## DNN algorithm configuration

- 30 inputs → PMTs signals (normalized to their sum)
- 8 hidden layers (64-128-64-32-16-8-4-2) → ~21k perceptrons
- 2 outputs → (x,y) positions
- perceptrons handled through a ReLU activation function.

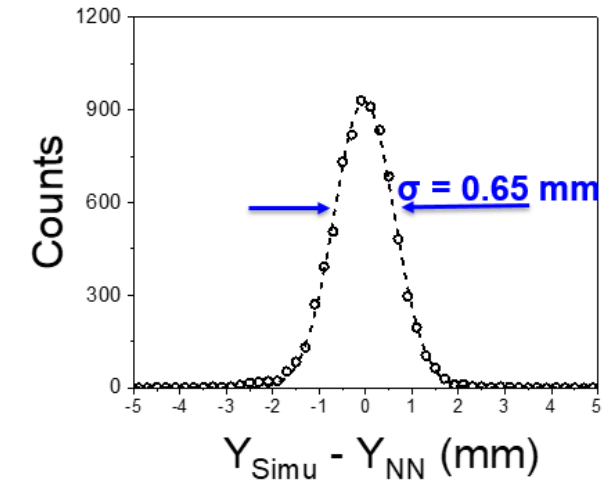
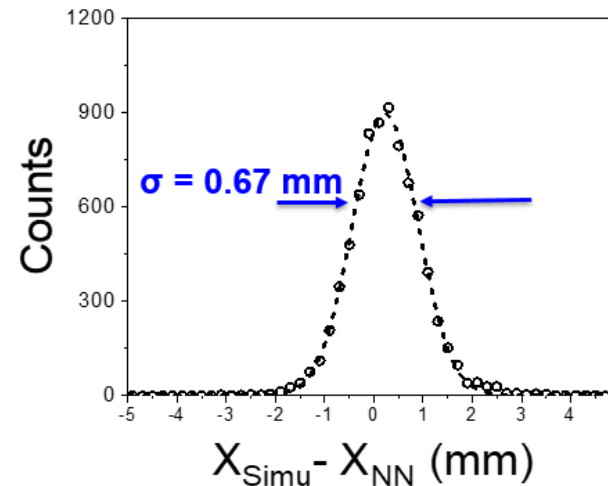

Good position ( $\sim 0.67 \text{ mm } \sigma$ ) and tracking ( $12 \text{ mrad } \sigma$ ) capability

# ELOSS Expected PID Performance

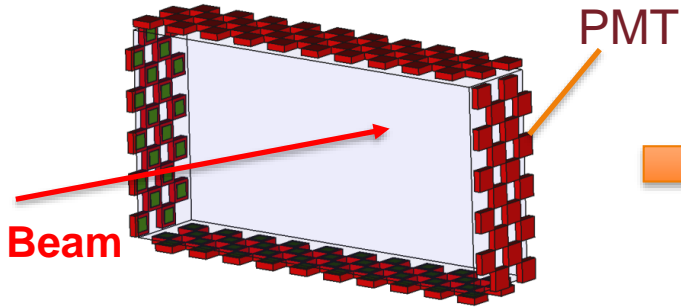

Monte Carlo simulation 100 MeV/u in 600 Torr ELOSS with uniform PMT sensitivity

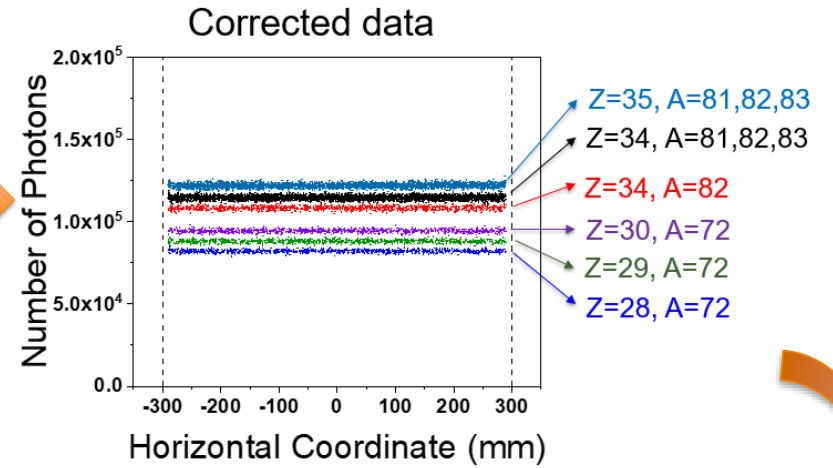
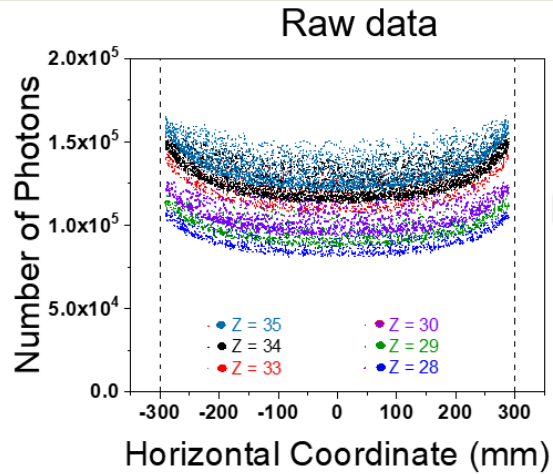

## Expected advantages compared to the conventional IC:

- ) 3 times better resolving power
- ) higher Z-resolution for heavy fragment ( $Z > 50$ )
- ) Large dynamic range
- ) Higher rate capability (up to a few hundred of kHz)
- ) Good time resolution ( $< 200$  ps) – not possible with IC
- ) Good localization capability ( $< 1$  mm) – not possible with IC

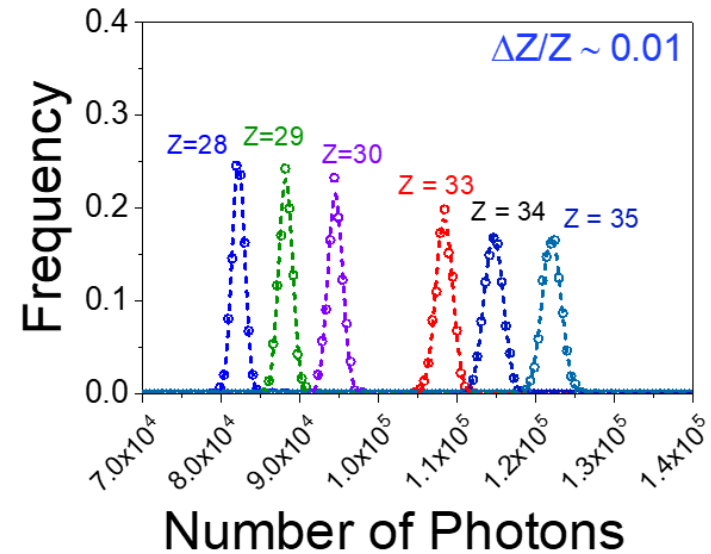

# Summary

- Exciting New Science opportunities from World-Class Equipment with Radioactive Isotope Beams: World-class equipment is needed to realize FRIB discovery potential and enable important new measurements capability in all FRIB science areas
- The S800 Spectrograph focal-plane detector system needs improvements in resolution and counting rate capability to take advantage of FRIB's heavier, and more intense, rare isotope beams
- The Energy Loss Optical Scintillation System (ELOSS) uses a high signal-to-noise optical readout to improve the energy resolution (1.2%→0.5%) and counting rate (5 kHz→50 kHz) of the  $\Delta E$  detector (ionization chamber)
- ELOSS Status: The detector and interfaces (e.g., GHS, DAQ and interface) have been fabricated and are ready for test beam. The interface to the signal processing circuit needs to be improved in order to optimize the SNR (increase PMT sensitivity). The test and development progress plan for commissioning will continue in 2025.

