

Adventures of a Newfound Quantum Mechanic

Paul Stankus, BNL

ORNL Physics Division Seminar

18 Feb 2021

1990's: Parody
2010's: Solid Advice

STUCK IN A DULL, LOW PAYING JOB?
WANT TO MAKE *BIG MONEY*?

**BE A
QUANTUM
MECHANIC!**

... EVEN IF YOU NEVER
FINISHED HIGH SCHOOL!

STUDY AT HOME!



THE COLUMBIA INSTITUTE OF QUANTUM MECHANICS, INC.

Not affiliated with the Columbia Broadcasting System, Columbia University, the District of Columbia, or Columbia, Gem of the Ocean.

CUT OUT AND SEND

Yes! I want to get in on the ground floor of this exciting new field. I understand no salesman will call.

NAME _____

ADDRESS _____

CITY, STATE, ZIP _____

COLUMBIA INSTITUTE OF QUANTUM MECHANICS
Suite 293, 1100 Back St., Improvidence, RI 02904

Quantum Computing, once all the rage...

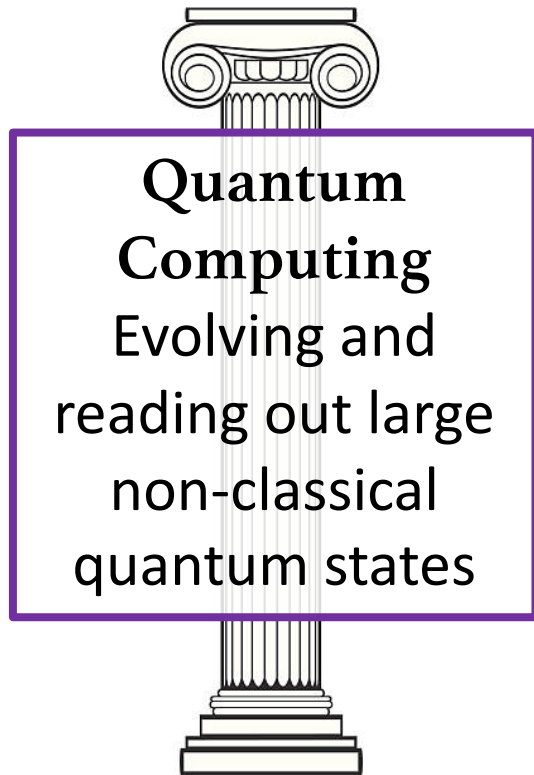

Quantum Information Science & Technology

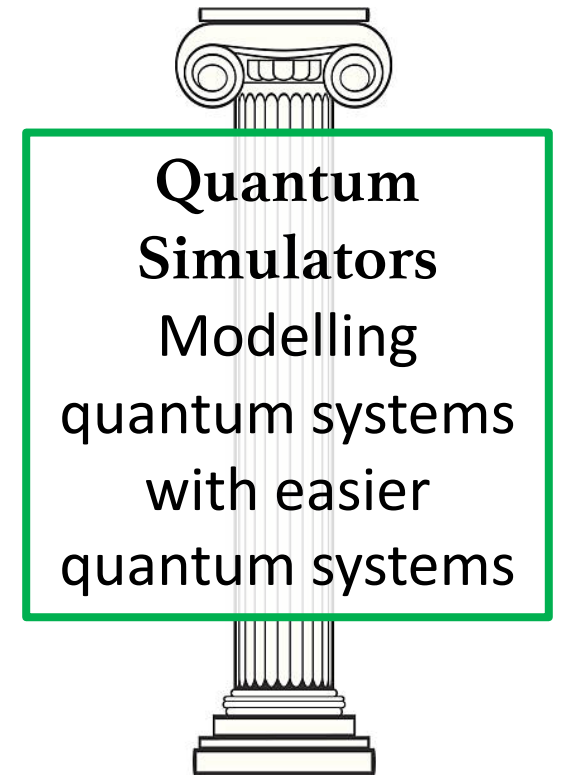
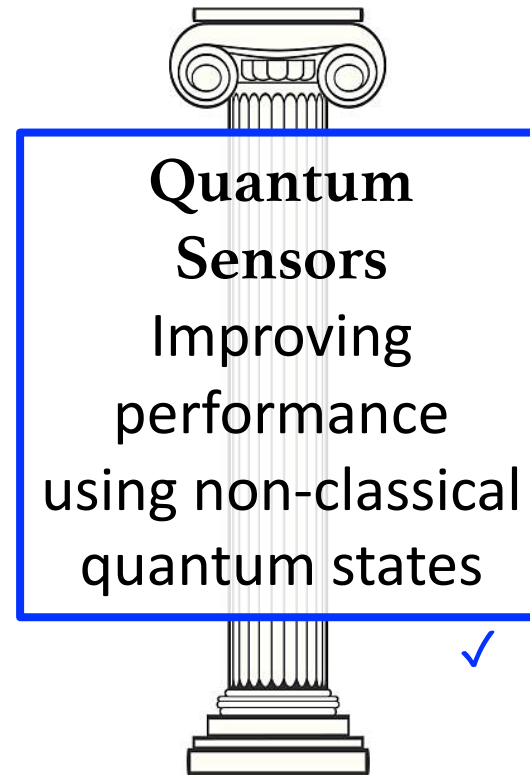
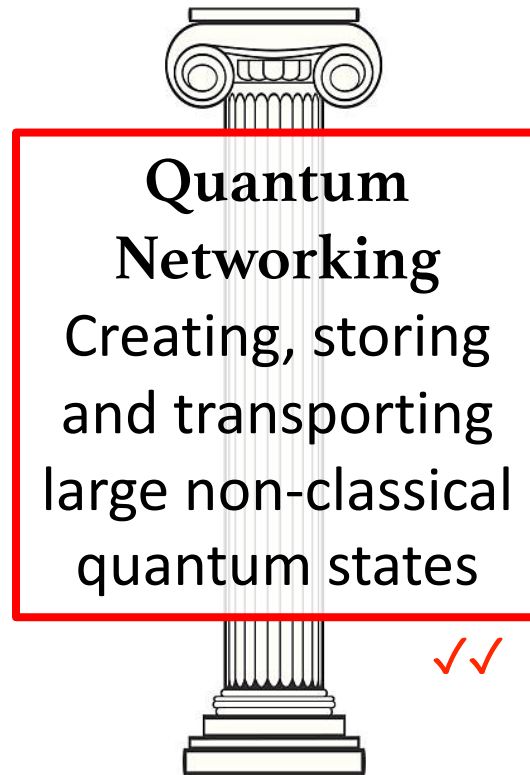
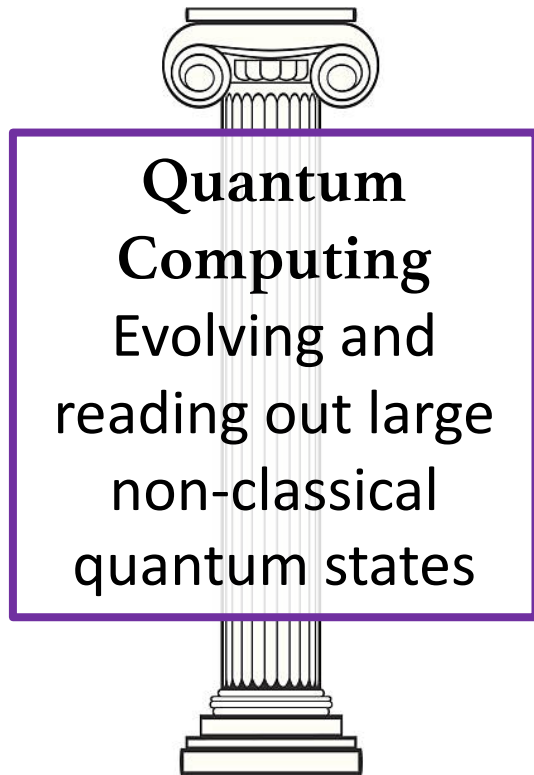

“Gentlemen, what are the four pillars?” -- Dead Poets Society (1989)

A Two-(Qu)Bit Hilbert Space

Separable States
Classical-like

Non-Separable States
No classical analogue
“Entangled”

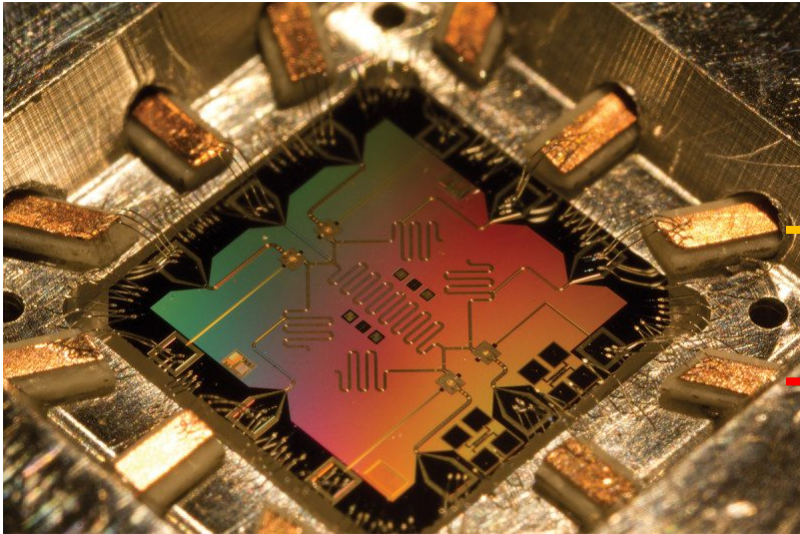

$|00\rangle$
 $|01\rangle$
 $|10\rangle$
 $|11\rangle$

$(|00\rangle + |11\rangle)/\sqrt{2}$
 $(|00\rangle - |11\rangle)/\sqrt{2}$
 $(|01\rangle + |10\rangle)/\sqrt{2}$
 $(|01\rangle - |10\rangle)/\sqrt{2}$

Quantum Computer

All the “oomph” of quantum technology
comes from using more dimensions in
multi-particle Hilbert space

Safety tip: No cloning allowed



Measuring a quantum system projects it into a basis state, so some information on the initial state is inevitably lost:
no general classical copying

Quantum copying turns out to be forbidden by the No-Cloning Theorem; more involved, can be seen as a consequence of information conservation

However, as long as a quantum state is not measured/projected then it *can be*

- Converted between physical qubit types (**Transduction**)
- Carried, carefully, over long distances (**Networking**)
- Stored and read back (**Quantum memories**)
- Destroyed in one place and re-incarnated in the same state somewhere else (**Teleportation, Entanglement Swapping**)

Quantum **T**ransduction

$$|XY\rangle_{QC} |00\rangle_{QTC} |\Phi\rangle_{RoW} \rightarrow |00\rangle_{QC} |XY\rangle_{QTC} |\Phi'\rangle_{RoW}$$

RoW = "Rest of the World"

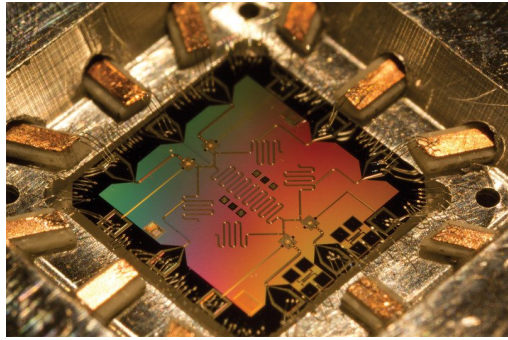

Quantum Computer
(QC)

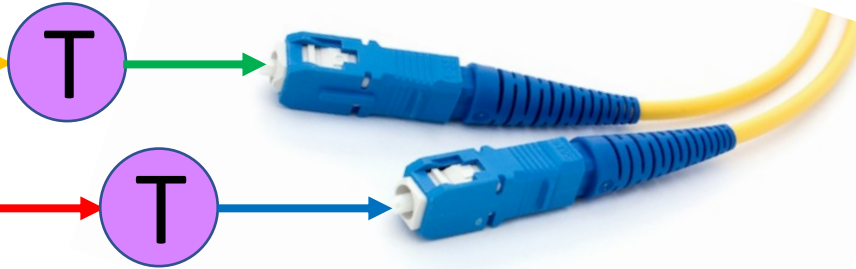

Quantum Transmission
Channel (QTC)

A necessary condition for quantum transduction is that the final state Φ' of the rest of the world is the same *independent* of the state of the qubits; this is equivalent to saying there is **no interaction** between the physical qubits and the outside world, e.g. **no information leakage**.

Linearity: $(|10\rangle_{QC} + |01\rangle_{QC}) |00\rangle_{QTC} |\Phi\rangle_{RoW} \rightarrow |00\rangle_{QC} (|10\rangle_{QTC} + |01\rangle_{QTC}) |\Phi'\rangle_{RoW}$

PWS currently PI for BNL LDRD to demonstrate quantum transduction between superconducting resonators and room-temperature photons, mediated by atomic vapor; details to follow.

Entanglement as a resource

Entangled pairs can be created, transmitted, and stored -- *where can I get some?*

$$|HH\rangle + |VV\rangle$$

Note: $|HH\rangle + |VV\rangle = |DD\rangle + |AA\rangle$

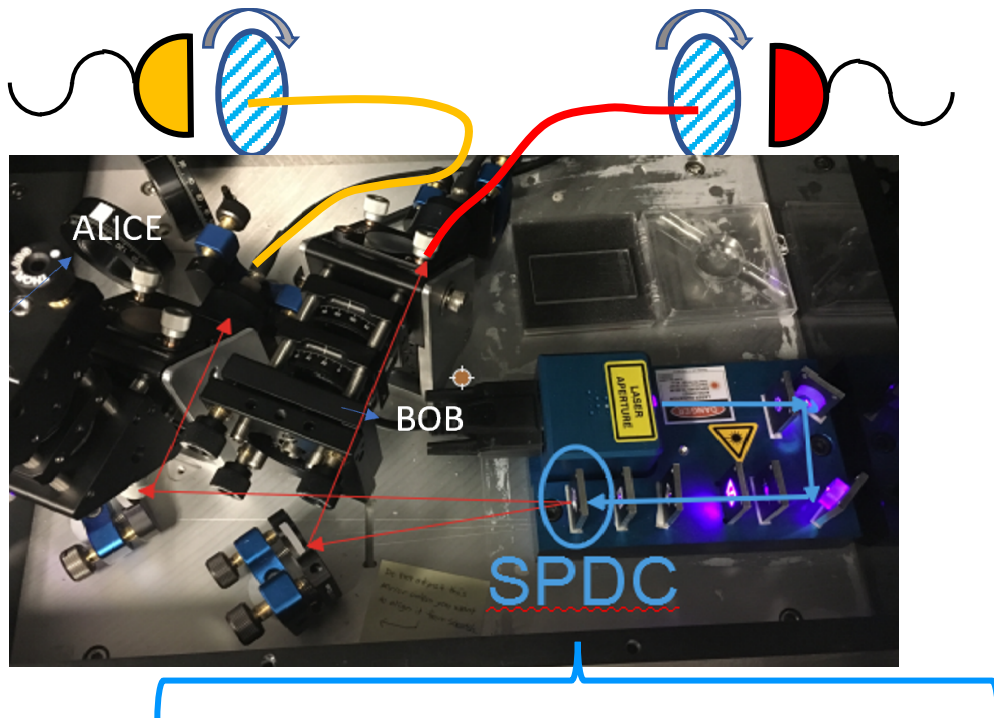

Pair
Rate

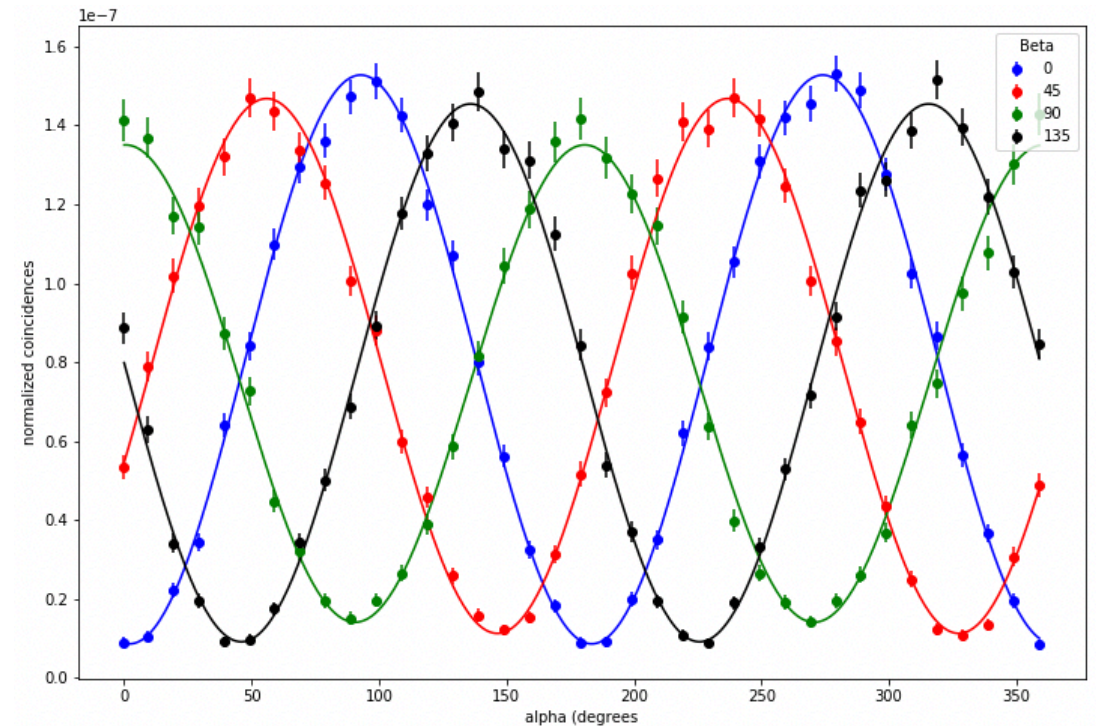

Polarizer angles

Polarization Entangled Photon Pair Creation

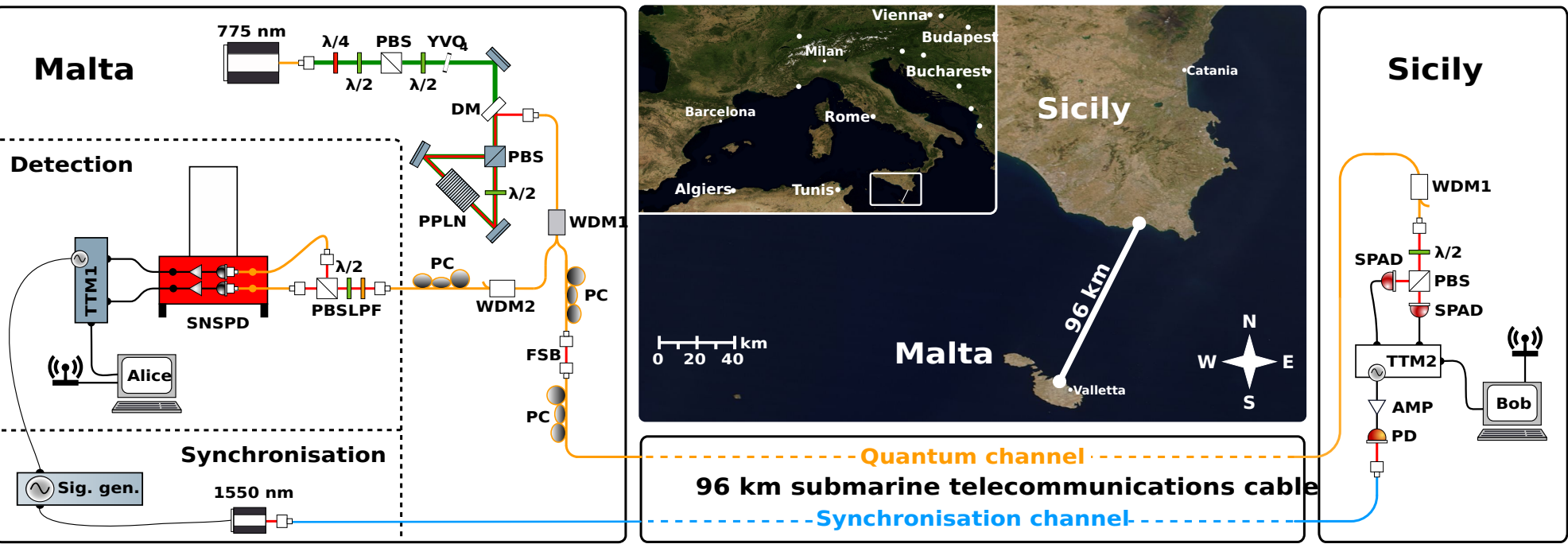

[arXiv:1803.00583](https://arxiv.org/abs/1803.00583)
[quant-ph]

In-field entanglement distribution over a 96 km-long submarine optical fibre*

Sören Wengerowsky,^{1,2, †} Siddarth Koduru Joshi,^{1,2} Fabian Steinlechner,^{1,2} Julien R. Zichi,^{3,4} Sergiy. M. Dobrovolskiy,⁴ René van der Molen,⁴ Johannes W. N. Los,⁴ Val Zwiller,^{3,4} Marijn A. M. Versteegh,³ Alberto Mura,⁵ Davide Calonico,⁵ Massimo Inguscio,^{6,7} Hannes Hübel,⁸ Anton Zeilinger,^{1,9} André Xuereb,¹⁰ and Rupert Ursin^{1,2, †}

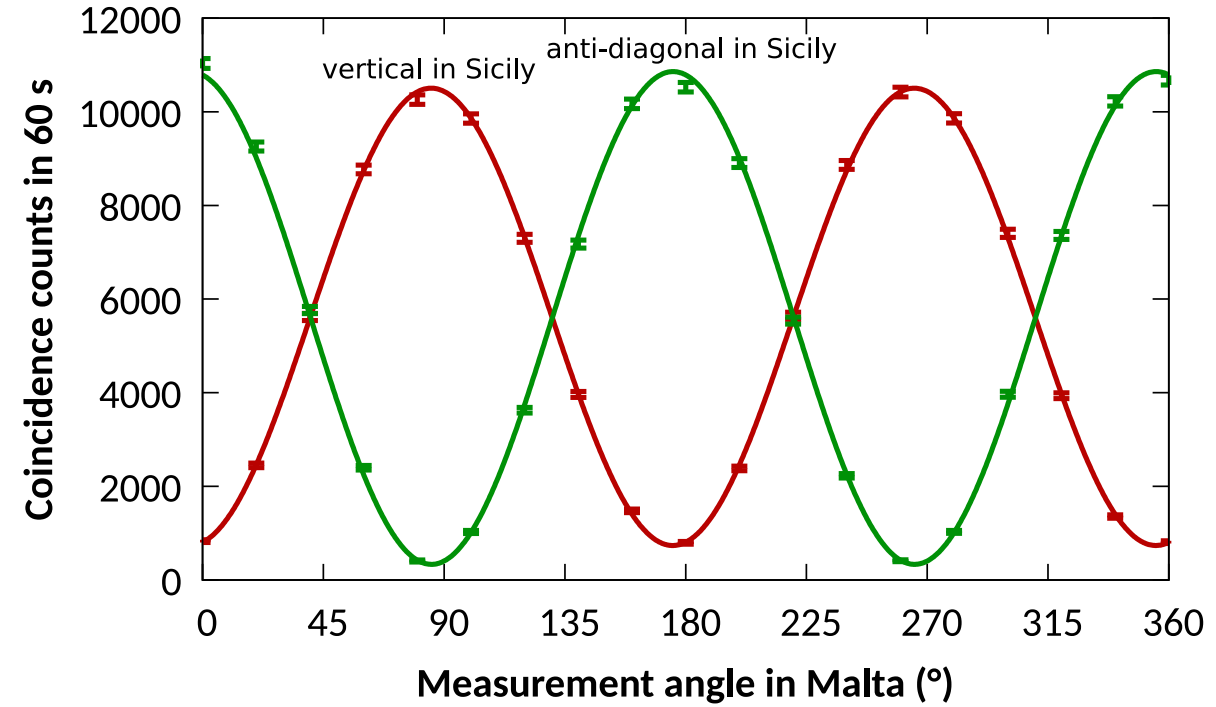

Quantum Cryptography: New killer app

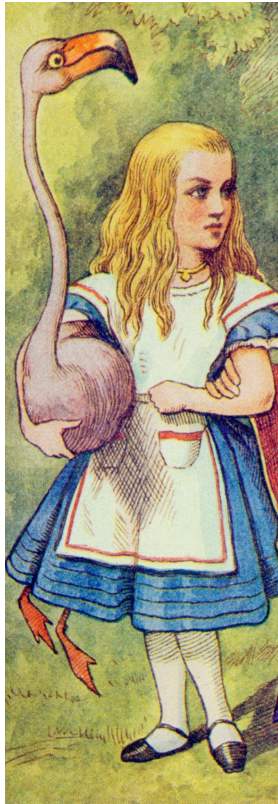

ALICE

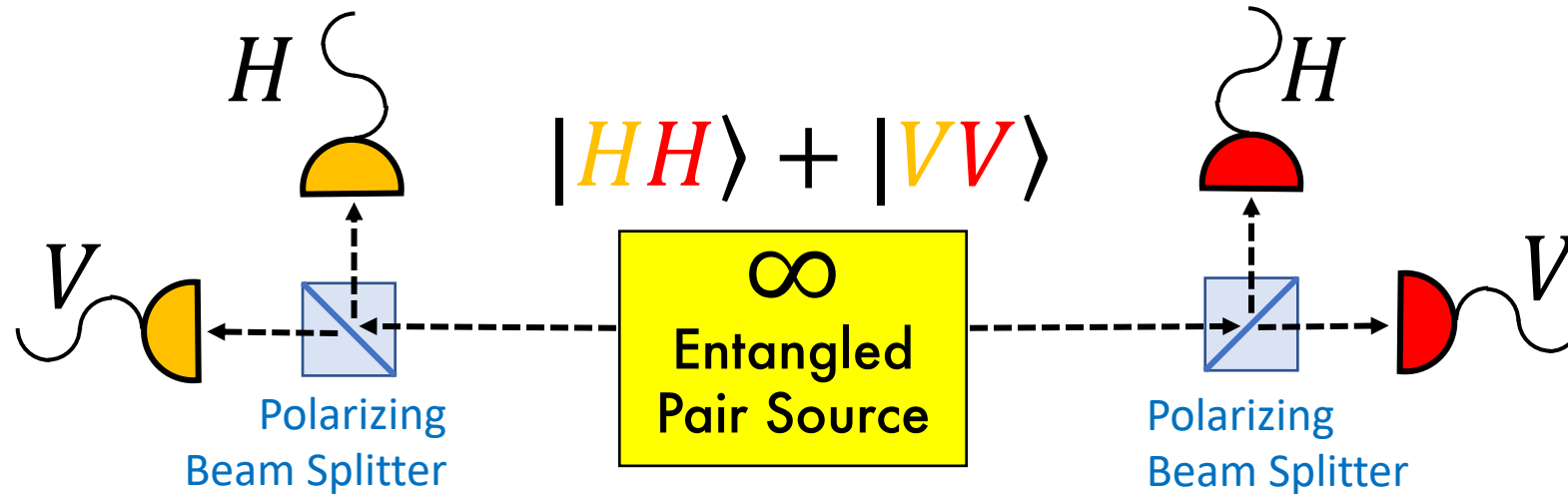

H
V
V
H
V
H

Random but perfectly
correlated observations
at two stations constitute
a **quantum key** for
cryptography

H
V
V
H
V
H

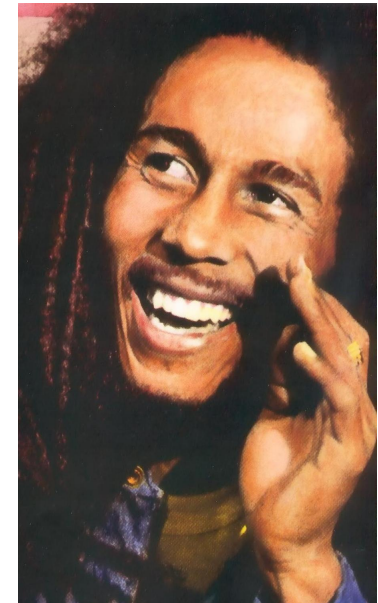

BOB

Quantum Cryptography: Vulnerability?



ALICE

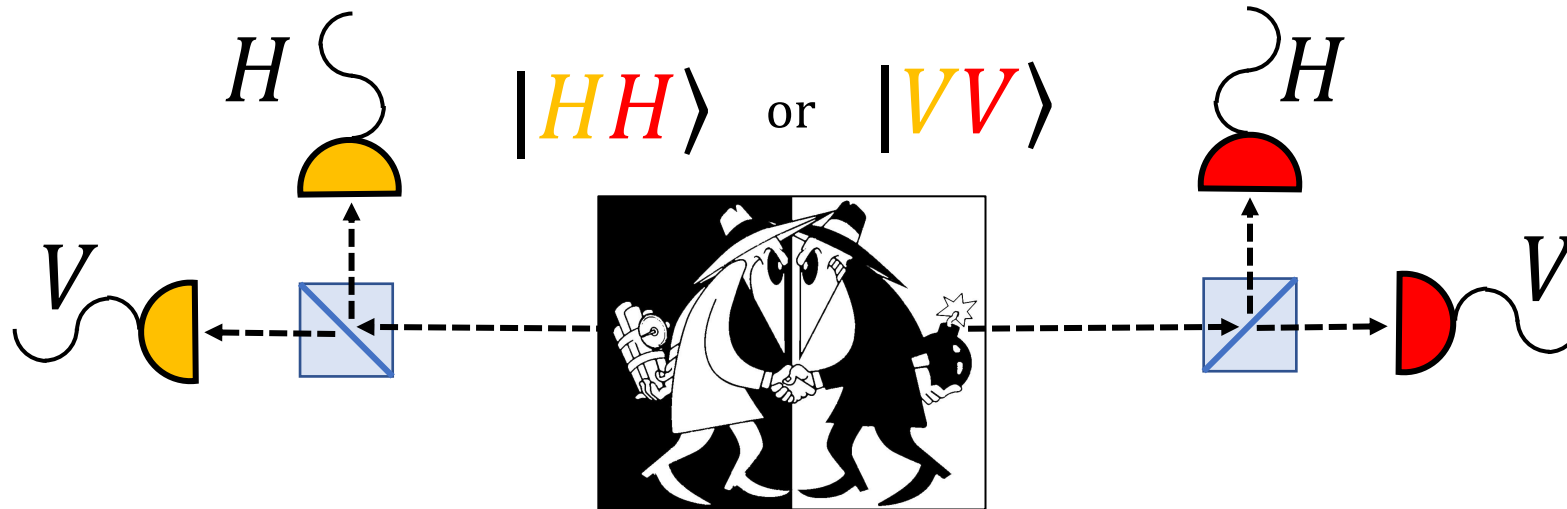

H
V
V
H
V
H

Interlopers can imitate the same effect by sending HH or VV at random, and they will then know the key

H
V
V
H
V
H

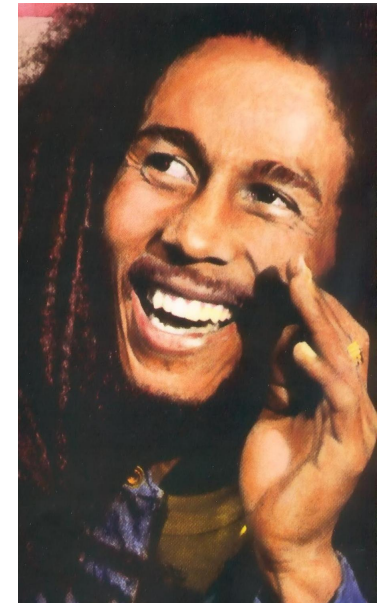

BOB

Quantum Cryptography: QM for the win



ALICE

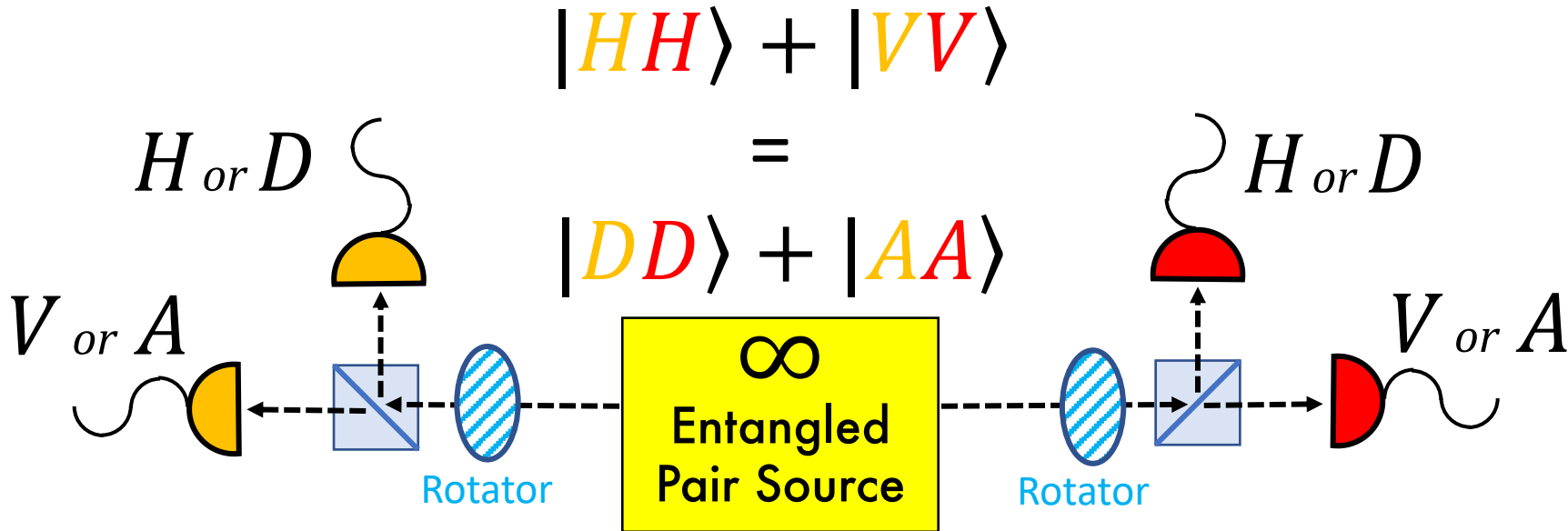

HV: H
 HV: V
 DA: A
 HV: H
 DA: D
 DA: A

Choose basis HV or AD
randomly at each station,
 results are **correlated** when
 basis choices are the **same**;
cannot be imitated

HV: H
 DA: D
 DA: A
 HV: H
 HV: V
 DA: A



BOB

Going the distance

Transmission of single photons over fiber limited to <100 Km – but remember, no cloning/copying, so nothing like a standard classical repeater/amplifier is possible

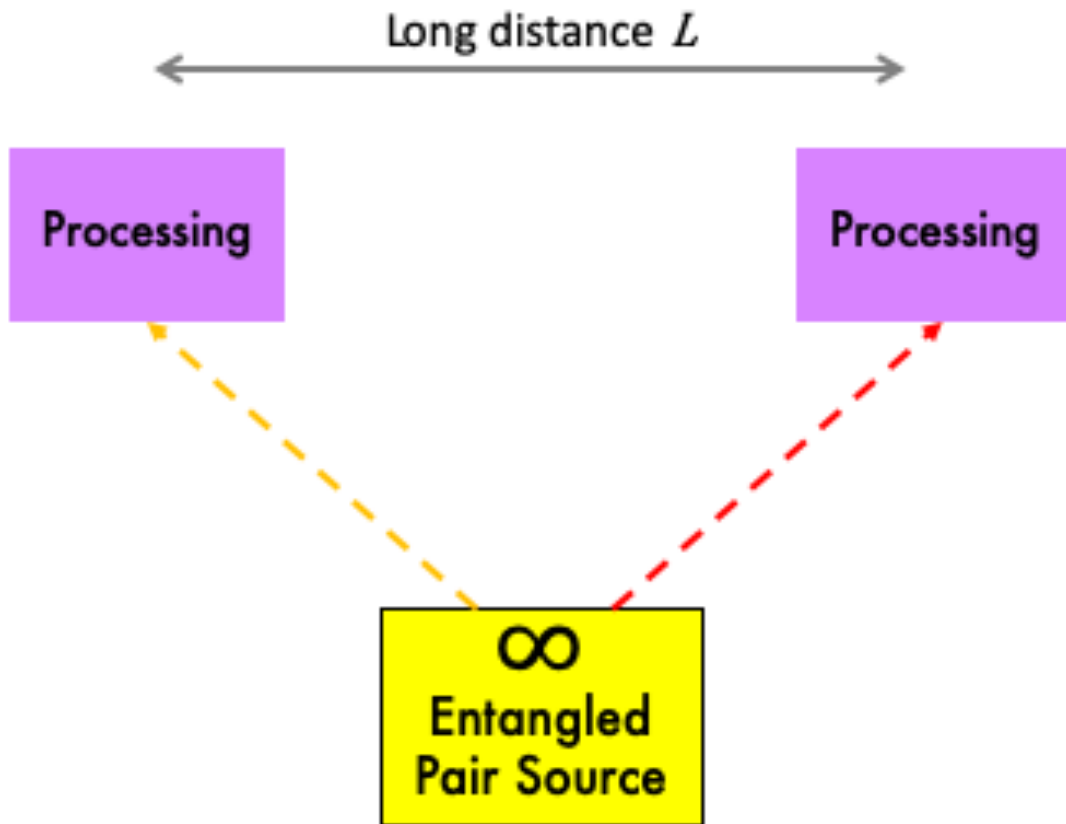

How to go farther? First we recall the set of fully entangled states, called the Bell State Basis:

$$(|HH\rangle + |VV\rangle)/\sqrt{2} \stackrel{\text{def}}{=} |\Phi^+\rangle$$

$$(|HH\rangle - |VV\rangle)/\sqrt{2} \stackrel{\text{def}}{=} |\Phi^-\rangle$$

$$(|HV\rangle + |VH\rangle)/\sqrt{2} \stackrel{\text{def}}{=} |\Psi^+\rangle$$

$$(|HV\rangle - |VH\rangle)/\sqrt{2} \stackrel{\text{def}}{=} |\Psi^-\rangle$$

One-hop *quantum repeater*

Initial wavefunction has two independent entangled pairs, AB and CD

$$\psi = (|HH\rangle + |VV\rangle) (|HH\rangle + |VV\rangle)/2 = |\Phi^+\rangle_{AB} |\Phi^+\rangle_{CD}$$

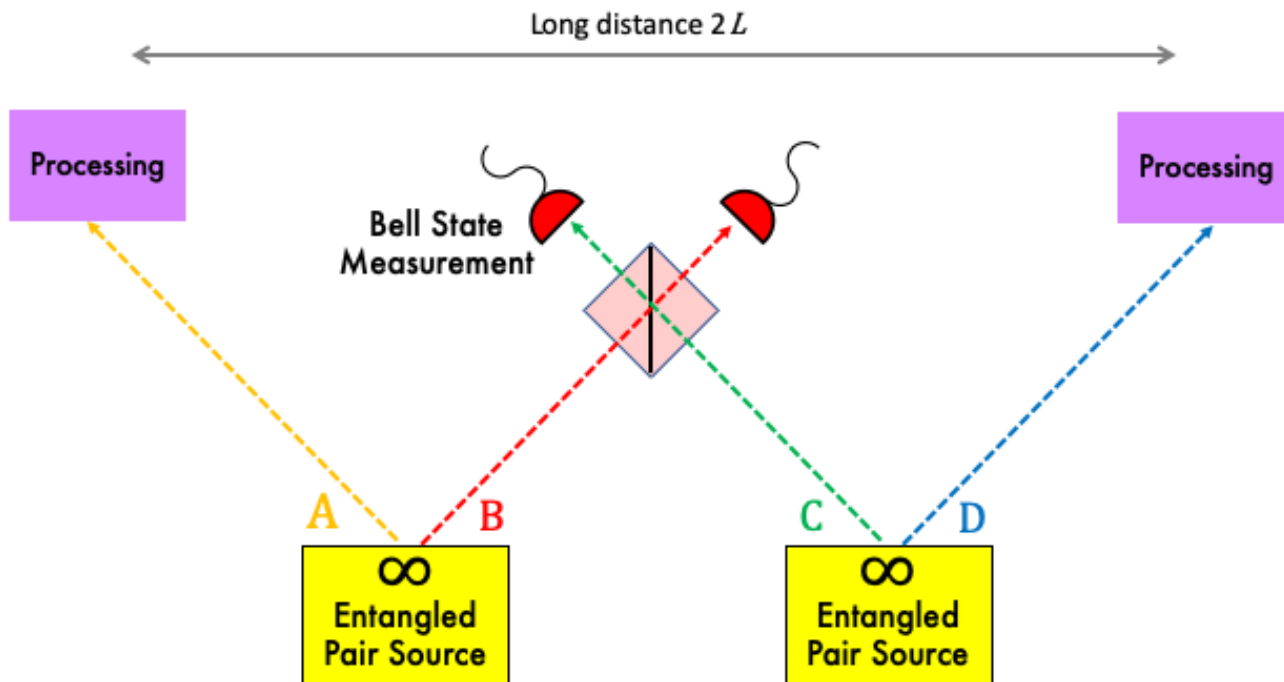

One-hop *quantum repeater*

After some algebra we can re-group A with D and B with C

$$\psi = |\Phi^+\rangle_{AD} |\Phi^+\rangle_{BC} + |\Phi^-\rangle_{AD} |\Phi^-\rangle_{BC} + |\Psi^+\rangle_{AD} |\Psi^+\rangle_{BC} + |\Psi^-\rangle_{AD} |\Psi^-\rangle_{BC}$$

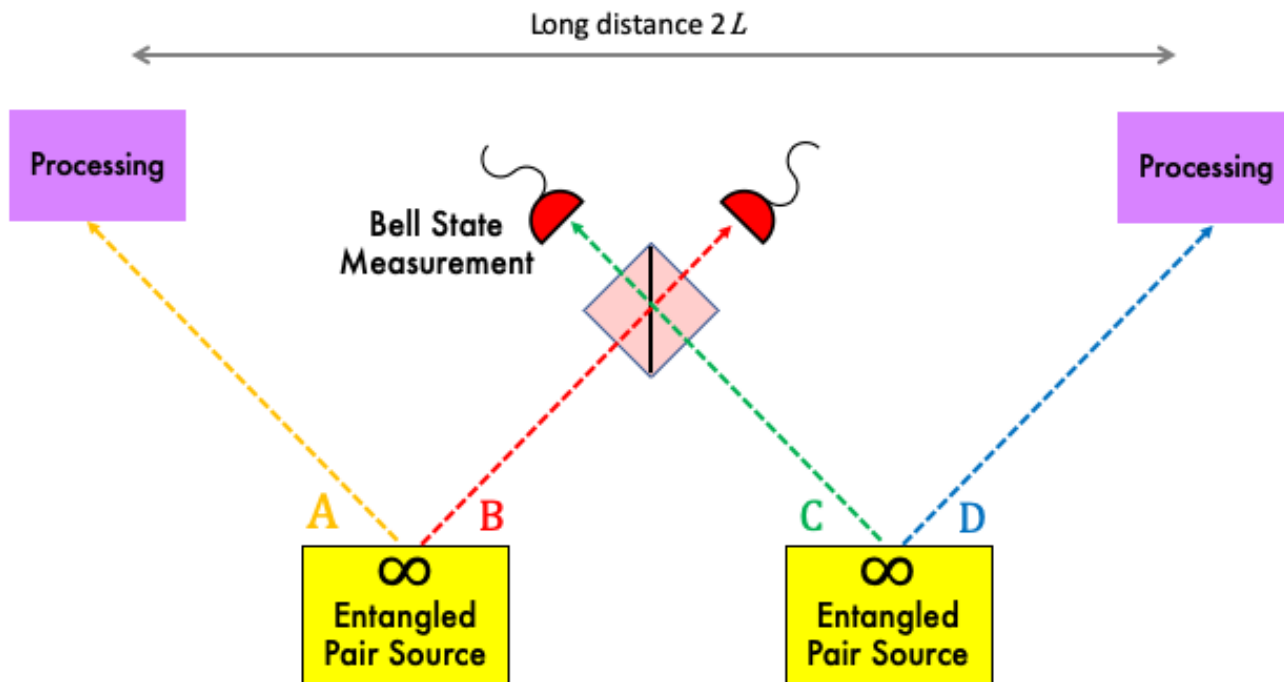

Measurement/projection of the BC pair in the Bell State basis will partially collapse the 4-particle wavefunction and leave the AD pair in a fully entangled state!

“Entanglement Swapping”

Repeat as necessary

In principle we can chain repeater stages for as many hops as are needed to go the desired distance, as long as we can generate the intermediate entangled pairs – a form of **teleportation** using *entanglement as a resource*.

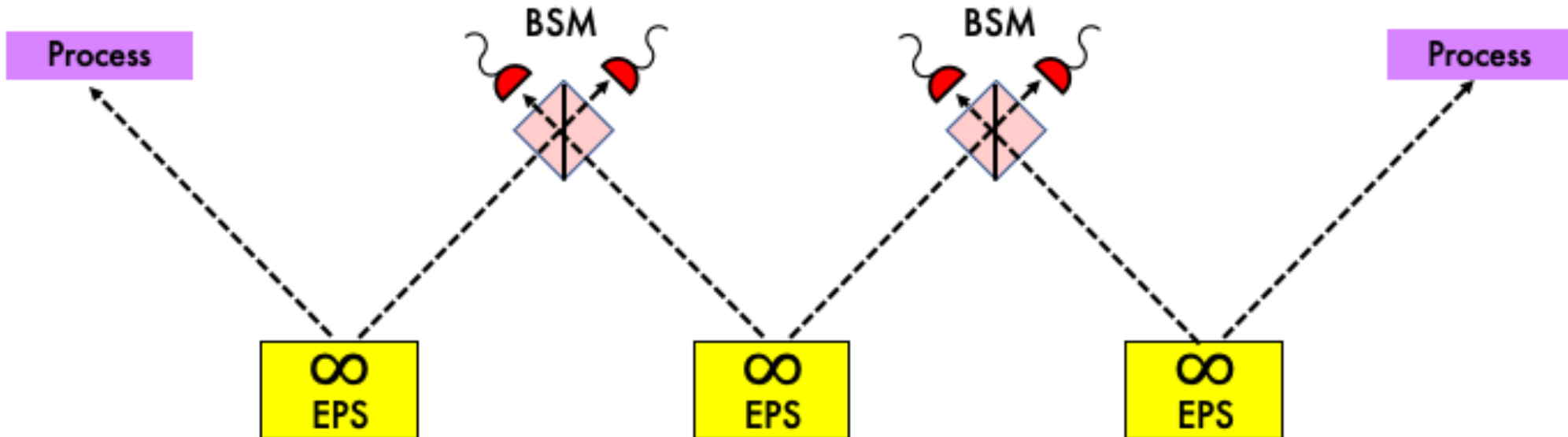

Q-LAN (really)

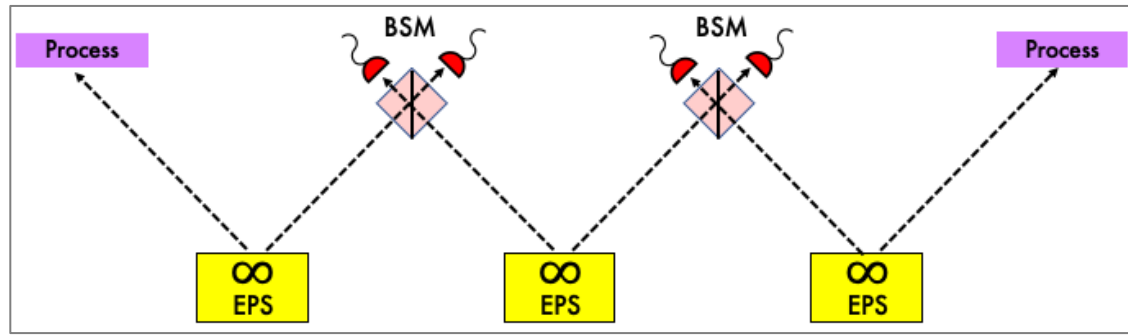

Theory

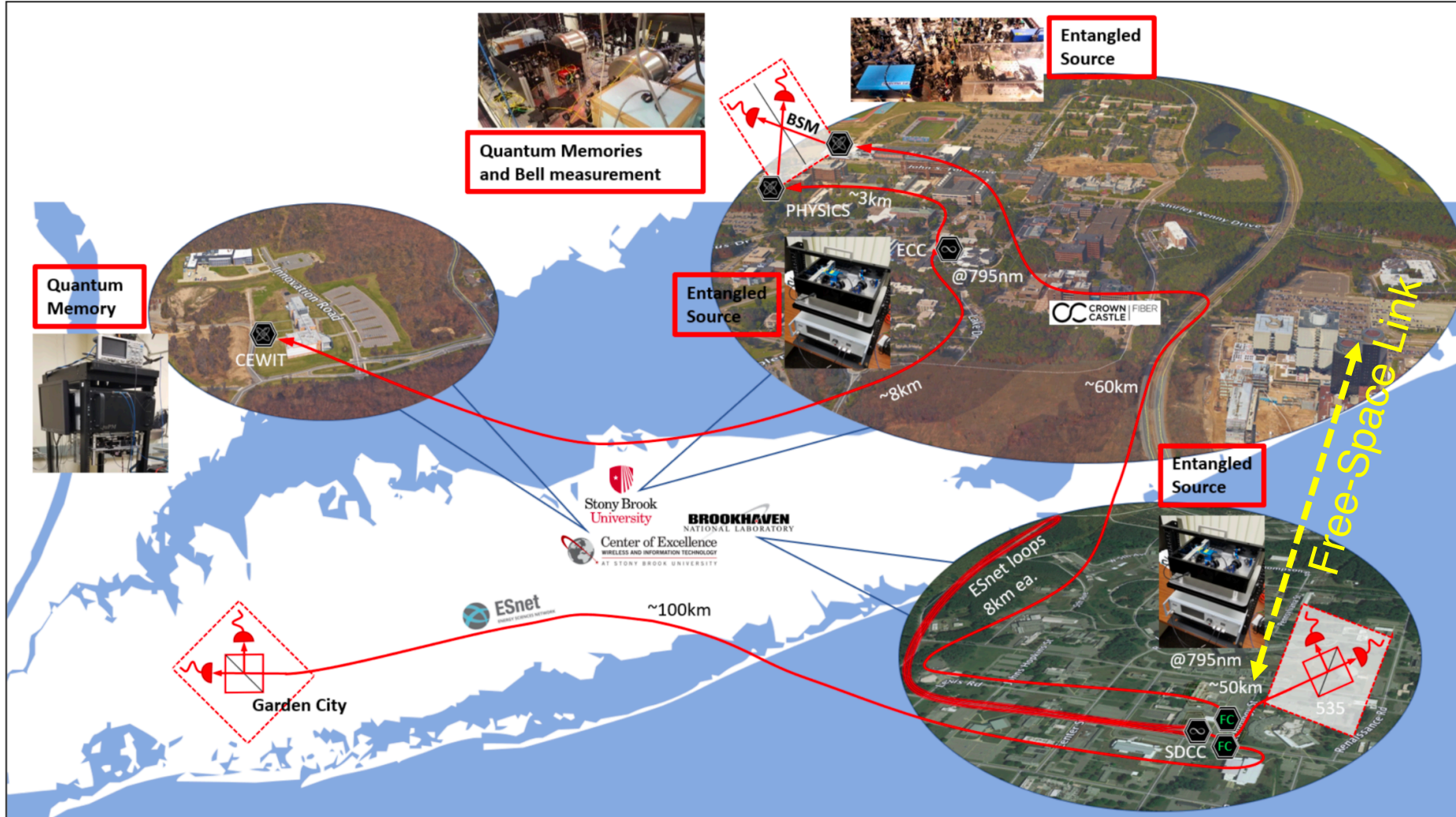

Practice

Memories and persistence

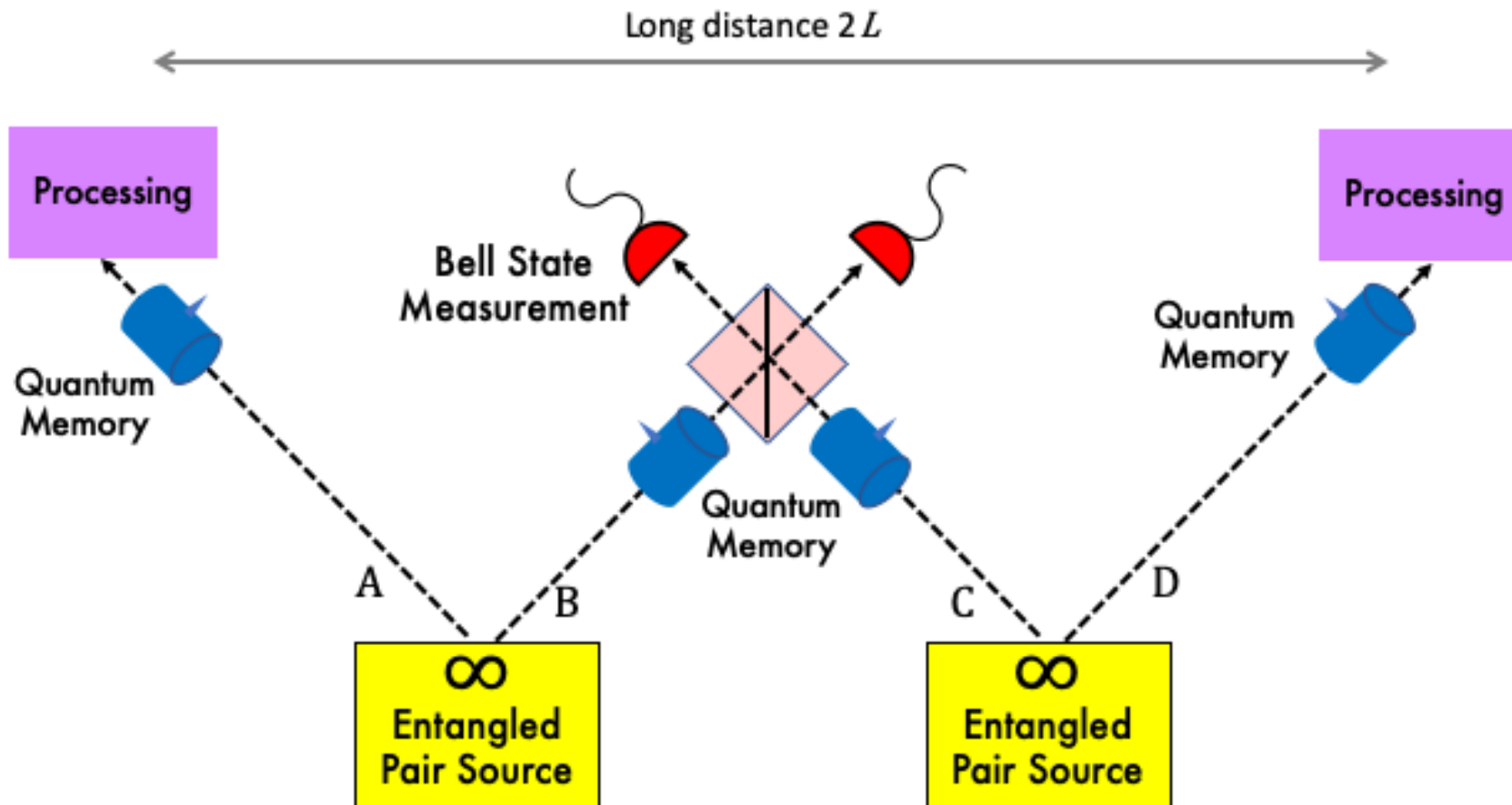

In practice, the generation and transmission of photons is *probabilistic*, and so the simple repeater depends on fortunate coincidence.

We can de-skew and greatly improve efficiency by storing successful transmissions in **quantum memories**.

Electromagnetically Induced Transparency (EIT)

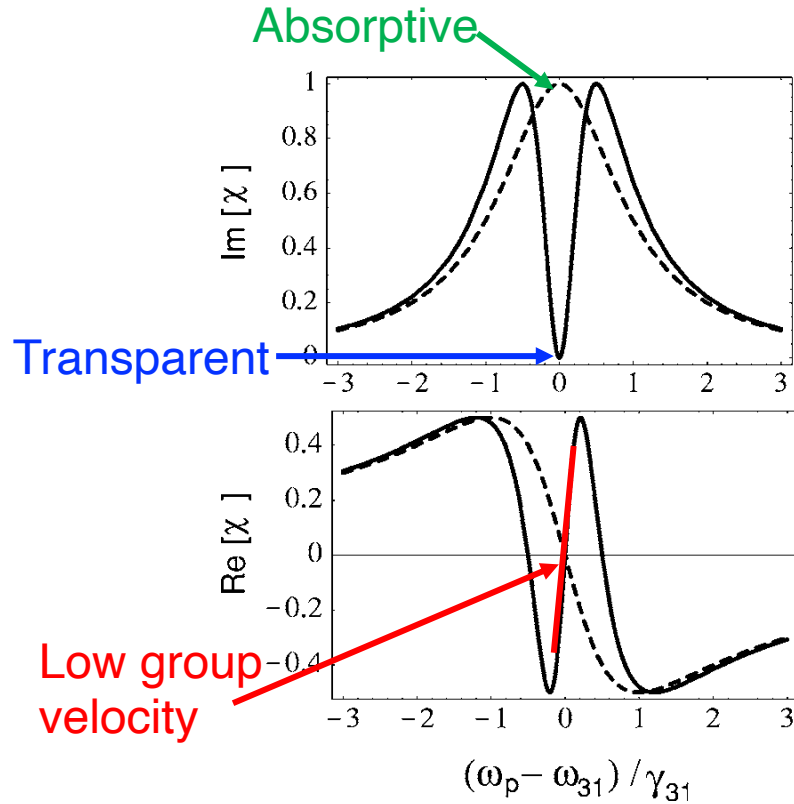
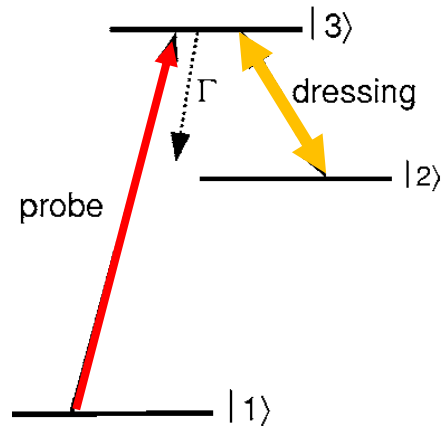
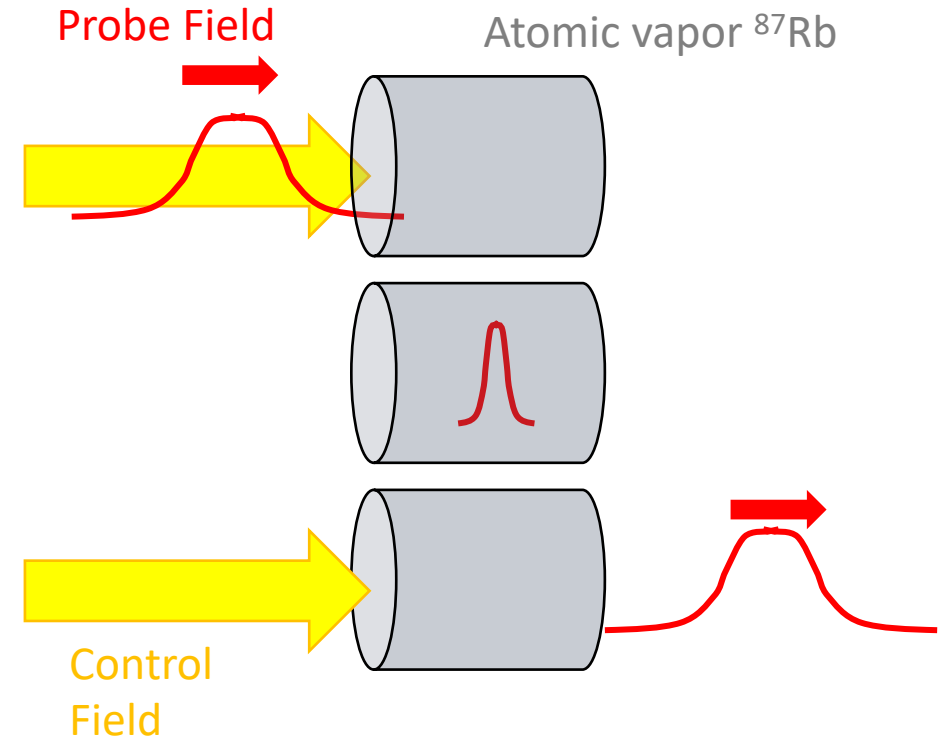

FIG. 1. Susceptibility as a function of the frequency ω_p of the applied field relative to the atomic resonance frequency ω_{31} , for a radiatively broadened two-level system with radiative width γ_{31} (dashed line) and an EIT system with resonant coupling field (solid line): top, imaginary part of $\chi^{(1)}$ characterizing absorption; bottom, real part of $\chi^{(1)}$ determining the refractive properties of the medium.



“Dark State Polariton”

$$|1\rangle - \frac{\Omega_P}{\Omega_C} |2\rangle$$



Storage is a *coherent* effect across all atoms in the vapor; non-projective

Room-temperature quantum memories

PHYSICAL REVIEW APPLIED 8, 034023 (2017)

Ultralow-Noise Room-Temperature Quantum Memory for Polarization Qubits

Mehdi Namazi, Connor Kupchak, Bertus Jordaan, Reihaneh Shahrokhshahi, and Eden Figueroa
Department of Physics and Astronomy, Stony Brook University, Stony Brook, New York 11794-3800, USA
(Received 27 July 2016; revised manuscript received 14 August 2017; published 25 September 2017)

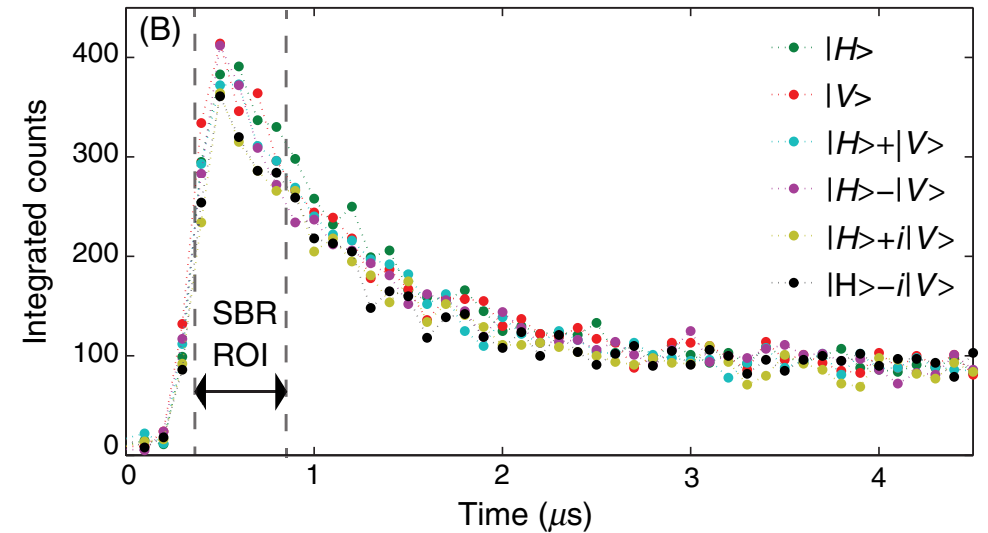
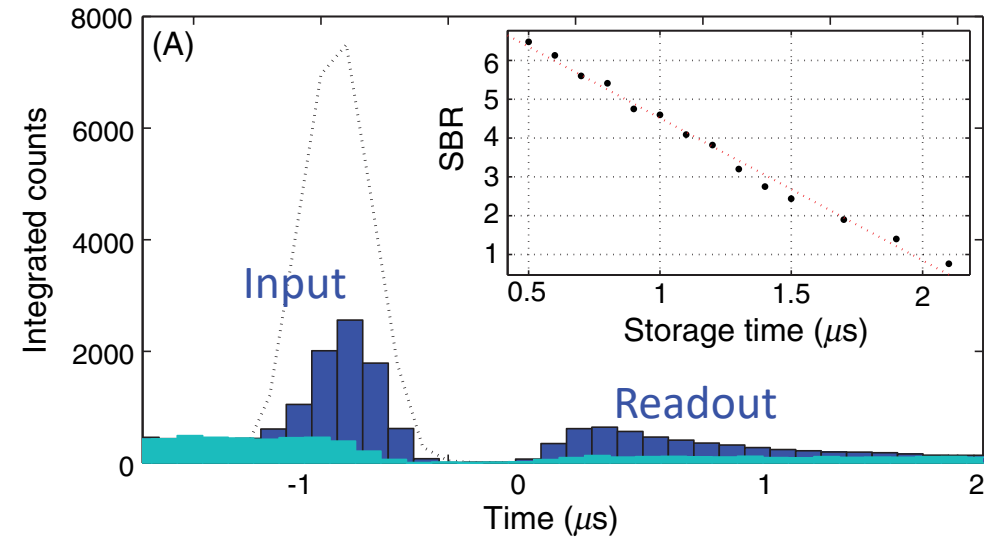
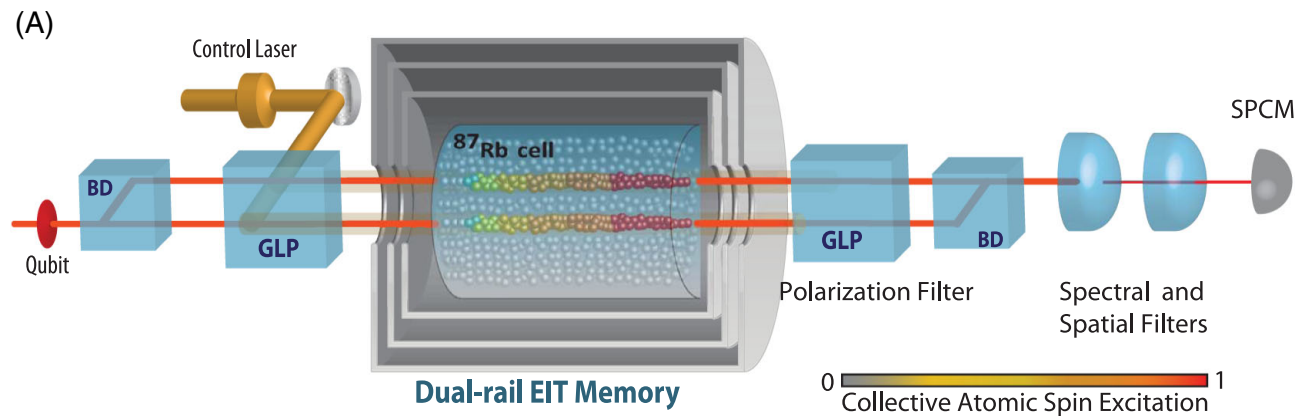

The Quantum Internet Will Blow Your Mind. Here's What It Will Look Like

October 2020

DISCOVER

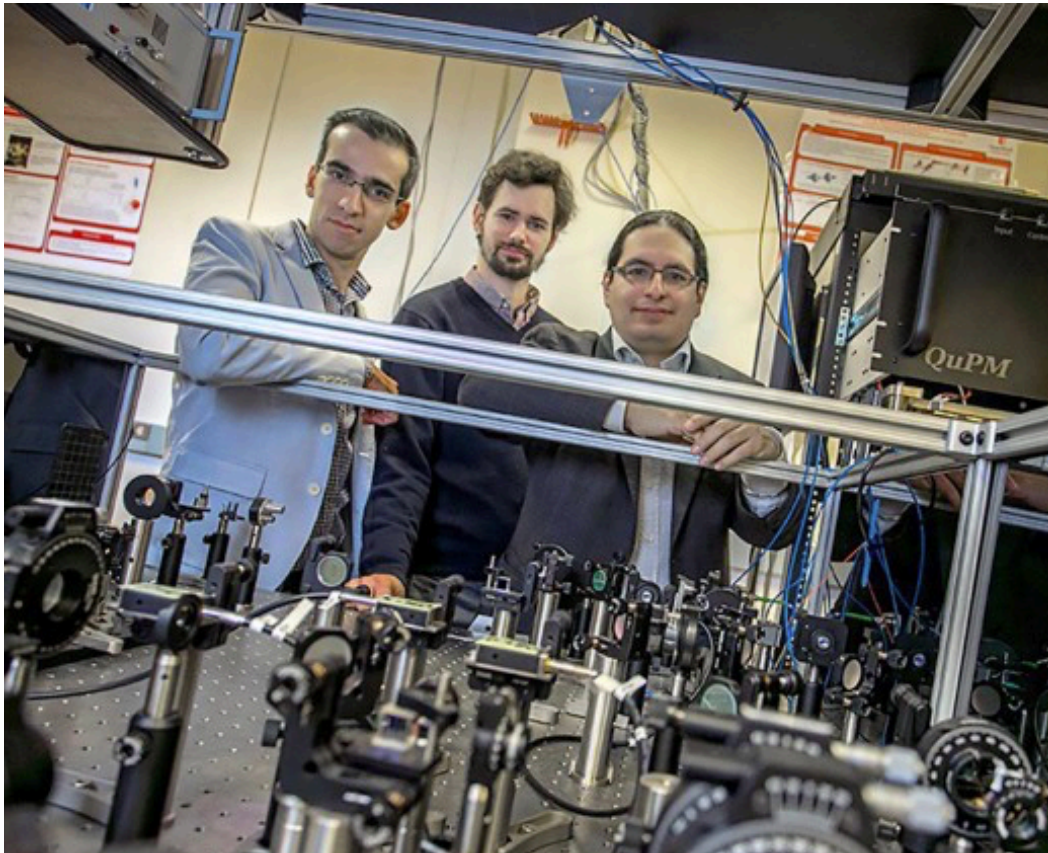

Mehdi Namazi, Mael Flament, Prof. Eden Figueroa

”There is no such thing as *good* publicity or *bad* publicity; there is only *more* publicity and *less* publicity”

-- Sam Goldwyn

The Key Device Needed for a Quantum Internet

June 30, 2020 • Physics 13, 104

As researchers worldwide work toward a potential quantum internet, a major roadblock remains: How to build a device called a quantum repeater.

physics.aps.org/articles/v13/104

INSIDE SCIENCE Reliable news for an expanding universe

CREATURE CULTURE EARTH HUMAN PHYSICS SPACE SPORTS TECHNOLOGY

US Takes an Important Step Toward Quantum Internet

A recent experiment has created a one-way quantum network between two labs, reaching a milestone on the path to creating a quantum internet.

<https://www.insidescience.org/news/us-takes-important-step-toward-quantum-internet>

The quantum internet | The Big Idea

By Jodi Goldberg | Published October 6 | Updated October 7 | The Big Idea | FOX 5 NY

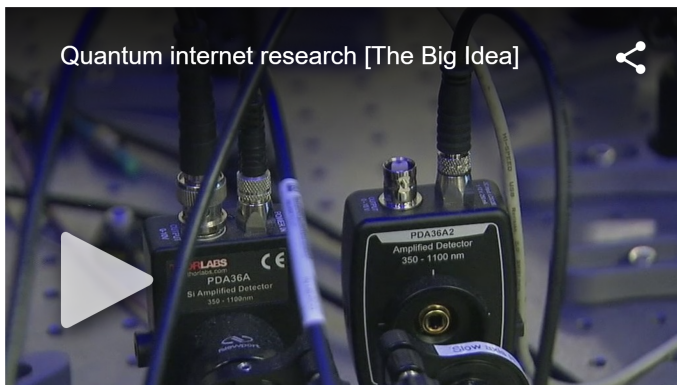

Latest News View More

ACLU: Trump administration not helping find migrant children's parents

fox5ny.com/news/the-quantum-internet-the-big-idea

BUSINESS / TECHNOLOGY

LI researchers work to create quantum internet

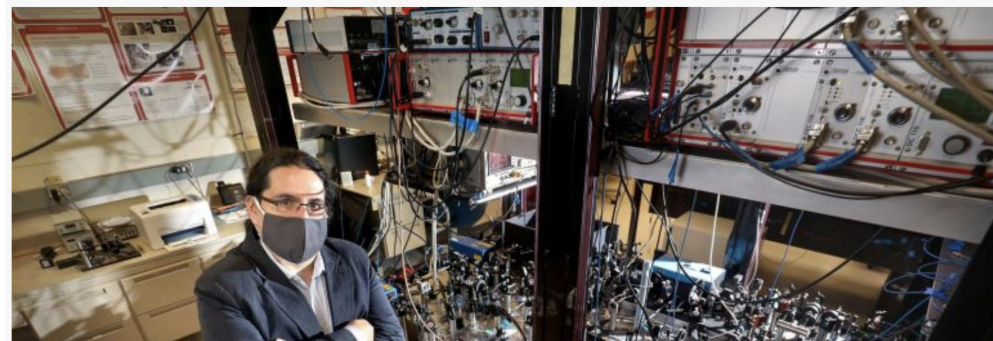

newsday.com/business/technology/quantum-internet-stony-brookhaven-laboratory-1.49712001

First-generation *Quantum Internet*

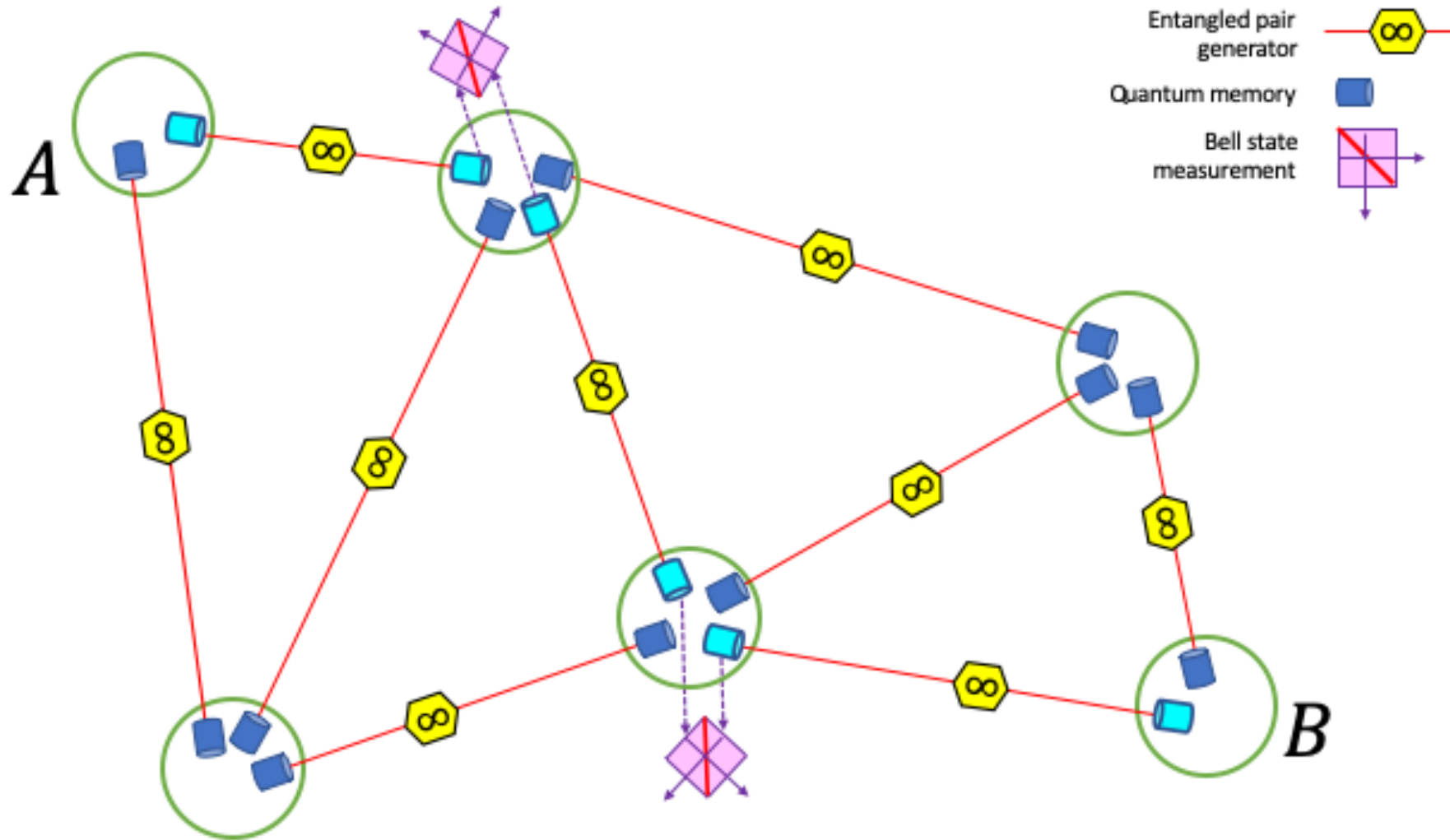

With links and memories, we can deliver entanglement to any pair of users on request

Local long distance experiments, SBU to BNL



Superconducting Nanowire
Single Photon Detector
(SNSPD) at BNL

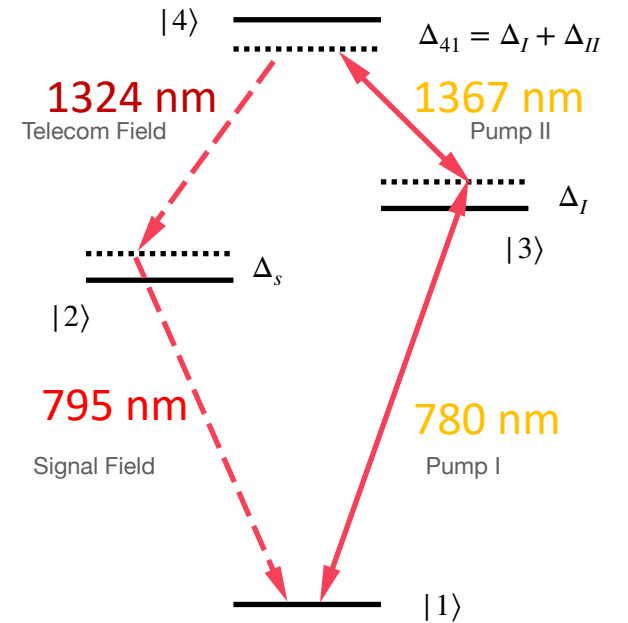
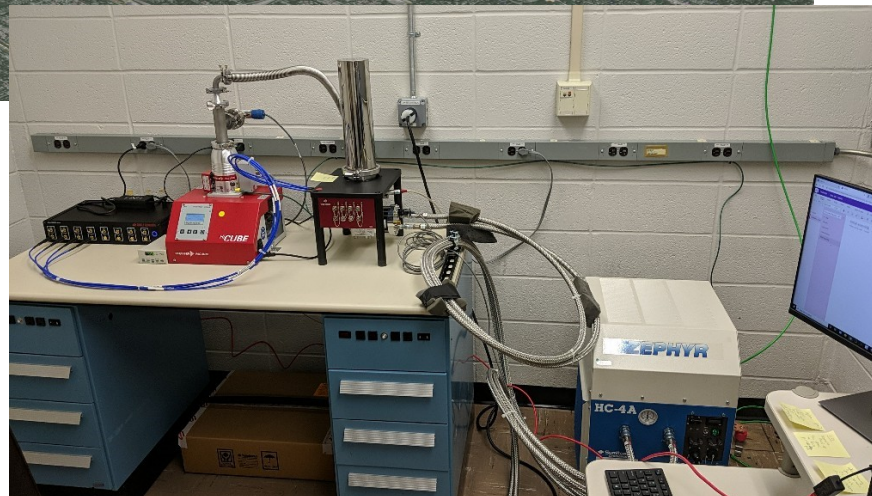

^{87}Rb level diagram for
795nm to 1324nm
conversion through
four-wave mixing

Mach-Zehnder single photon interference

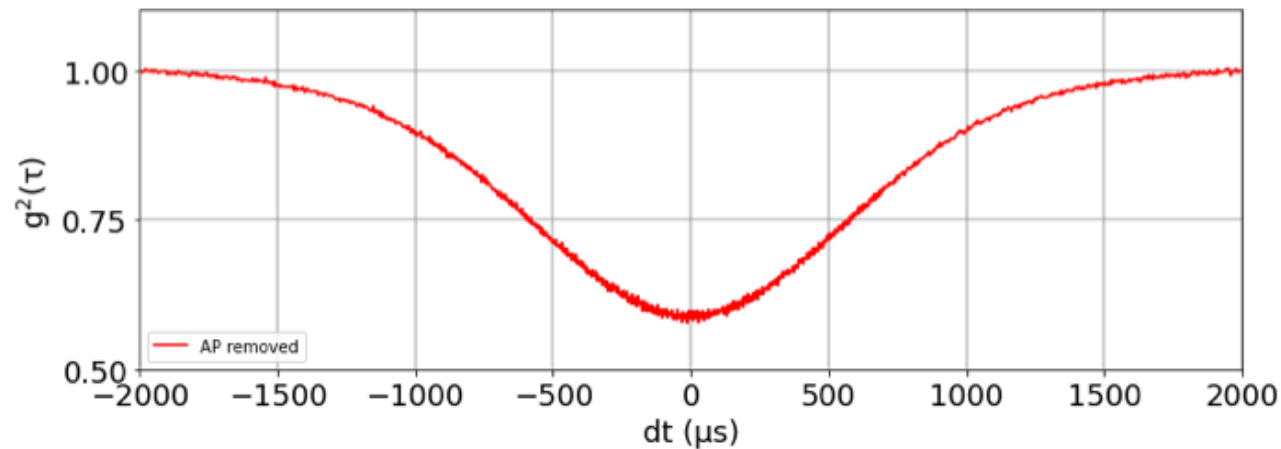
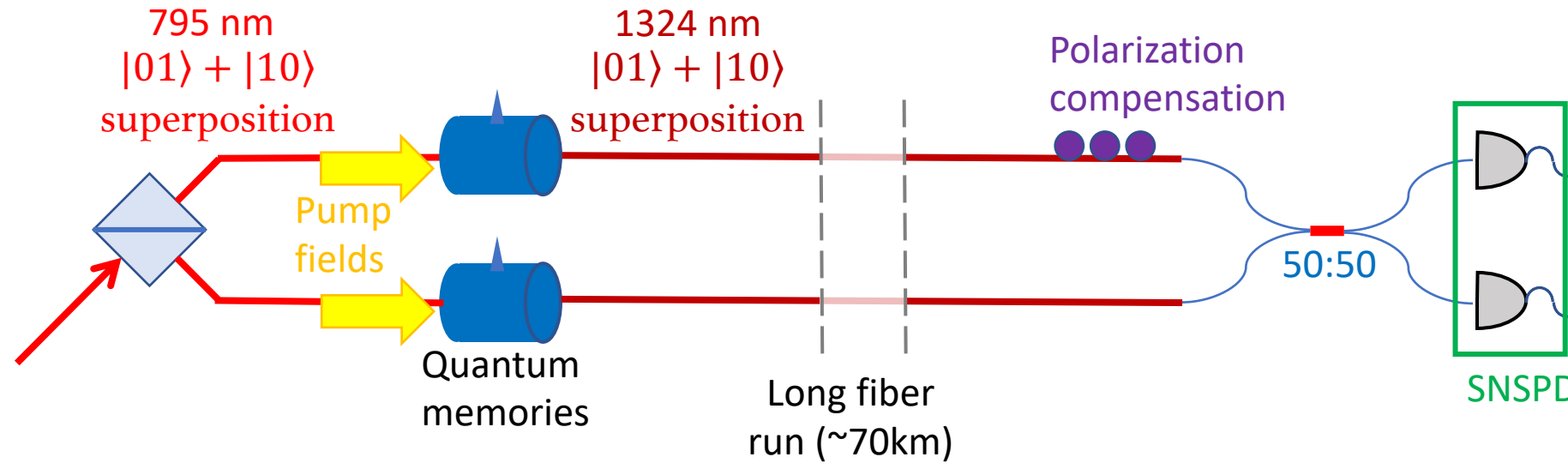

Anti-correlation between the two detector channels shows that subsequent photons “steer” the same way, showing that **superposition is preserved** through conversion *and* transmission.

Hong-Ou-Mandel Two-Photon Interference

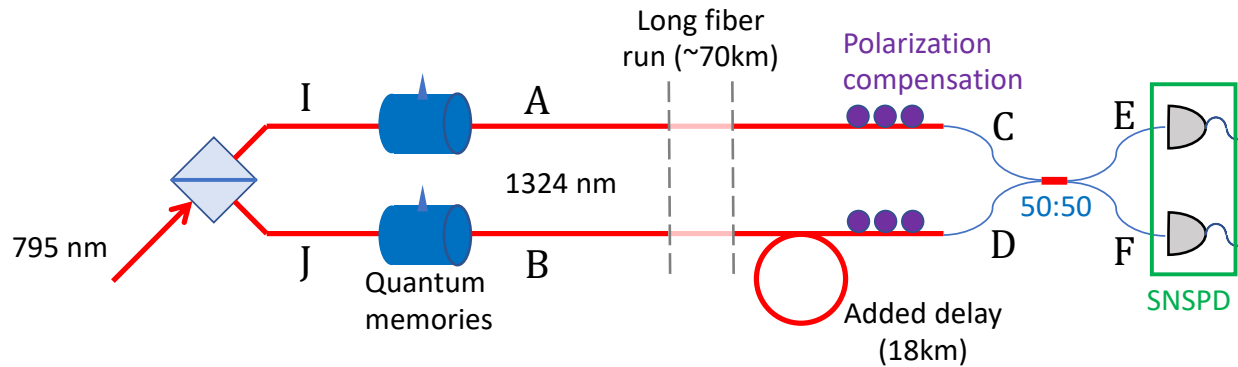

With added delay, we look for two independent photons arriving at the final beam splitter.

Hong-Ou-Mandel (HOM) interference dip shows that the two photons are *indistinguishable*

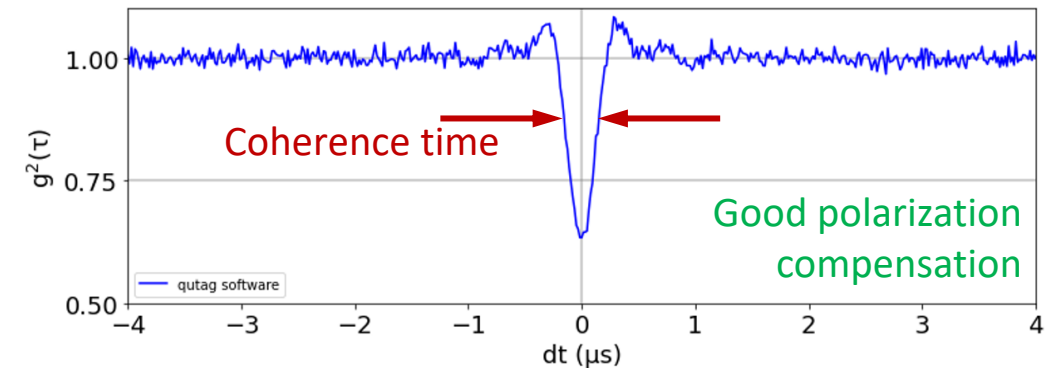
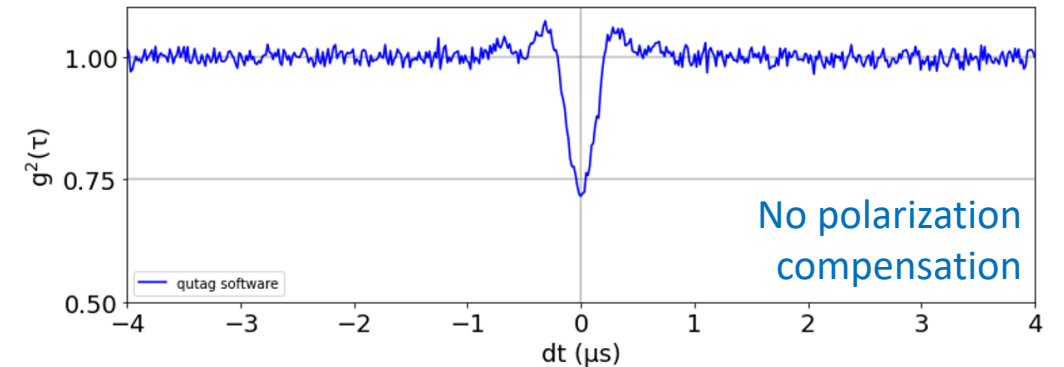
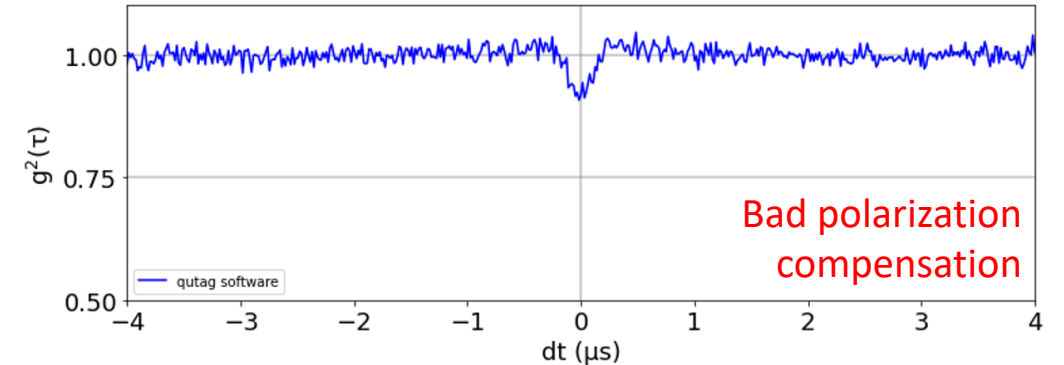

Network-in-progress

- The (near?) future *Quantum Internet* will distribute *entanglement as a resource* to pairs of users on demand
- All the necessary ingredients have been demonstrated: transduction, transmission, entanglement swapping, and quantum memories
- Our Long Island collaboration is in a good position to build out the first quantum local area network

And now for something not so
completely different...

$$\psi = (|HH\rangle + |VV\rangle) (|HH\rangle + |VV\rangle)/2 = |\Phi^+\rangle_{AB} |\Phi^+\rangle_{CD}$$

$$|1\rangle - \frac{\Omega_P}{\Omega_C} |2\rangle$$

$$(|HH\rangle + |VV\rangle)/\sqrt{2} \stackrel{\text{def}}{=} |\Phi^+\rangle$$

$$(|HH\rangle - |VV\rangle)/\sqrt{2} \stackrel{\text{def}}{=} |\Phi^-\rangle$$

$$(|HV\rangle + |VH\rangle)/\sqrt{2} \stackrel{\text{def}}{=} |\Psi^+\rangle$$

$$(|HV\rangle - |VH\rangle)/\sqrt{2} \stackrel{\text{def}}{=} |\Psi^-\rangle$$