

Electronics Design Improvements

Chuck Britton, Nance Ericson, Kyle
Reed, Emma Brown, Leah Broussard,
Austin Nelson, Andrew Hagemeyer

8 Feb 2023

Design Improvements Include

- Need to make two changes to opamp power
 - Need to add resistor/capacitor filtering at each power pin
 - Add local regulators to each pin
- Need to remove +/- 5V and +12V power planes from board
- Improve input filtering to each regulator.
- Decide upon output filtering for some channels
- Remove BUG (big ugly cap) from board.
- Add filter caps to existing input side of power boards

Power Distribution Channel

Power

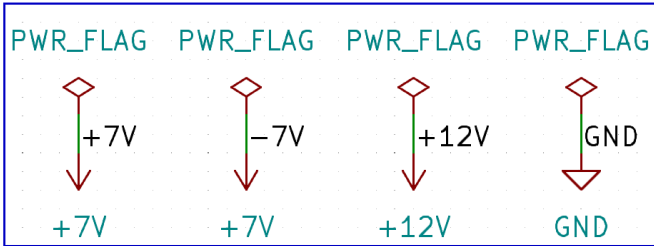

Needs caps

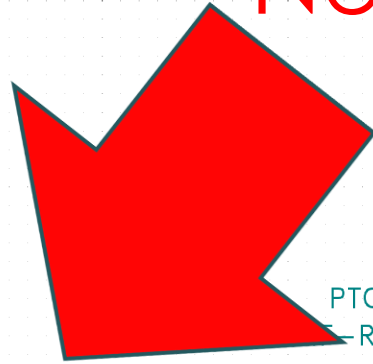

From DC supply

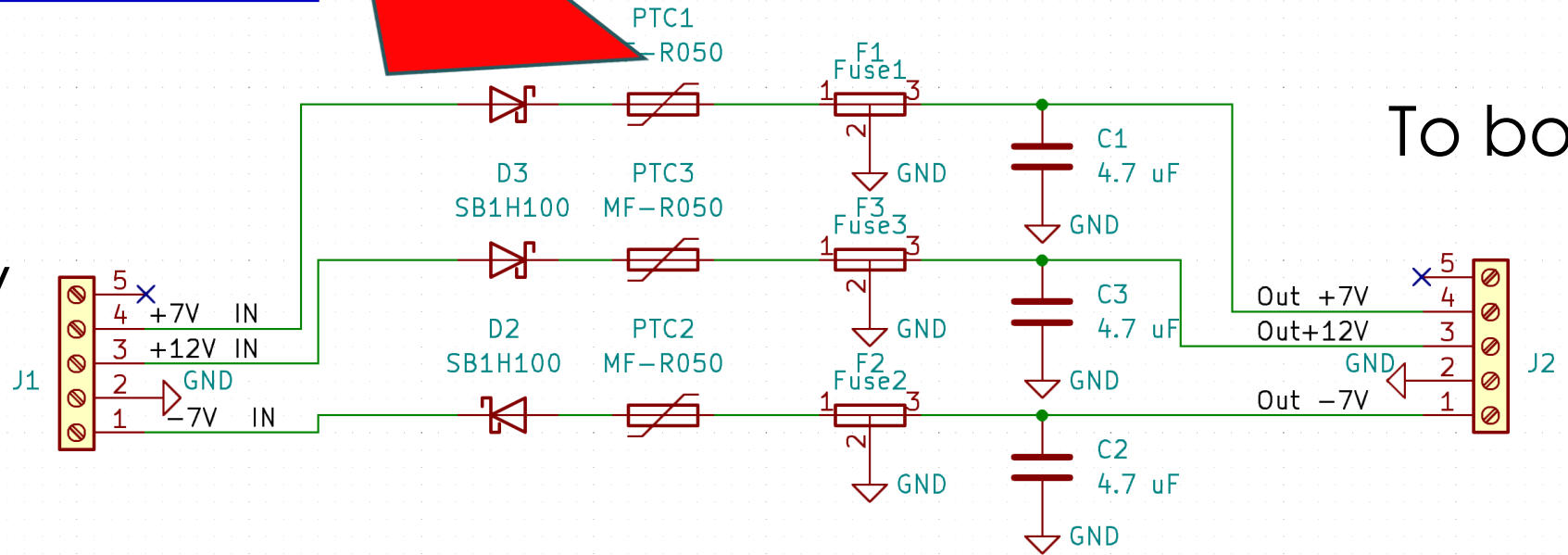

To boards