

# Exploring CEvNS at the 100 eV Frontier with the NUCLEUS Experiment

Victoria Wagner,  
Technical University of Munich

June 29<sup>th</sup>, 2023

Oak Ridge National Laboratory, TN, USA

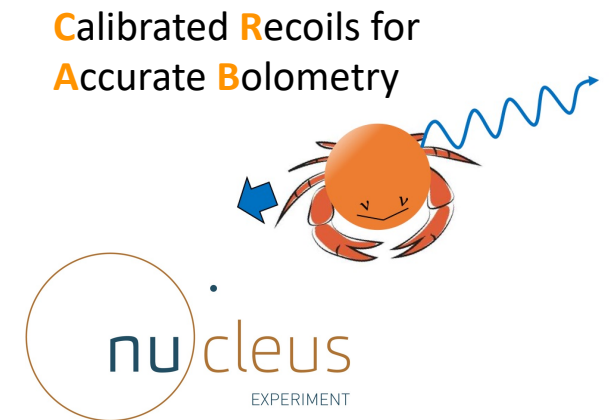

# Outline

---

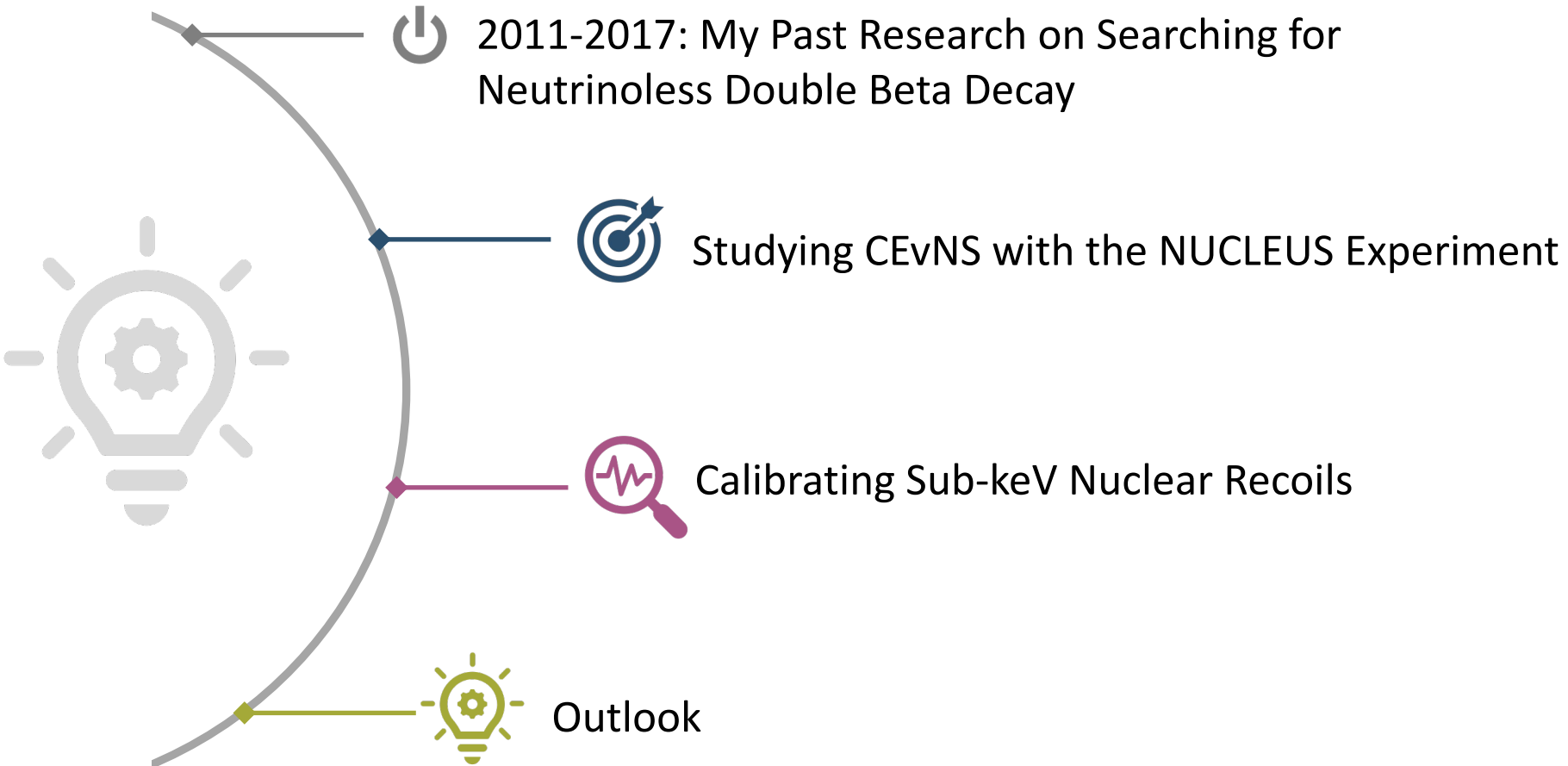

# Outline

---



2011-2017: My Past Research on Searching for Neutrinoless Double Beta Decay



Studying CEvNS with the NUCLEUS Experiment



Calibrating Sub-keV Nuclear Recoils



Outlook

# Searching for $0\nu\beta\beta$ with the GERDA Experiment

- Lepton number violation
- Access to absolute neutrino mass & hierarchy

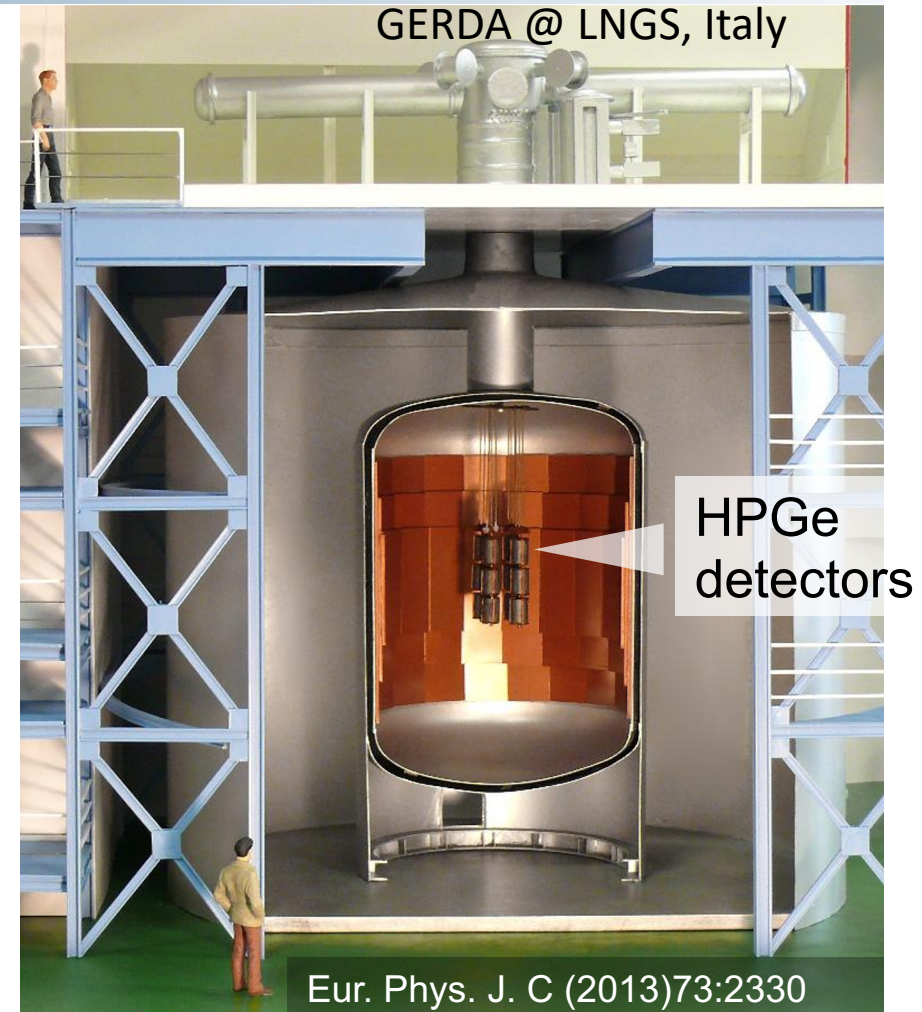
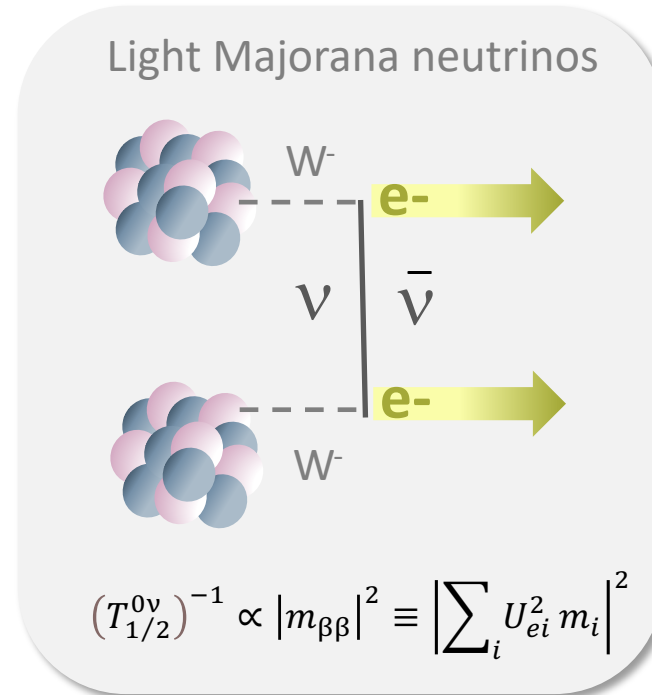
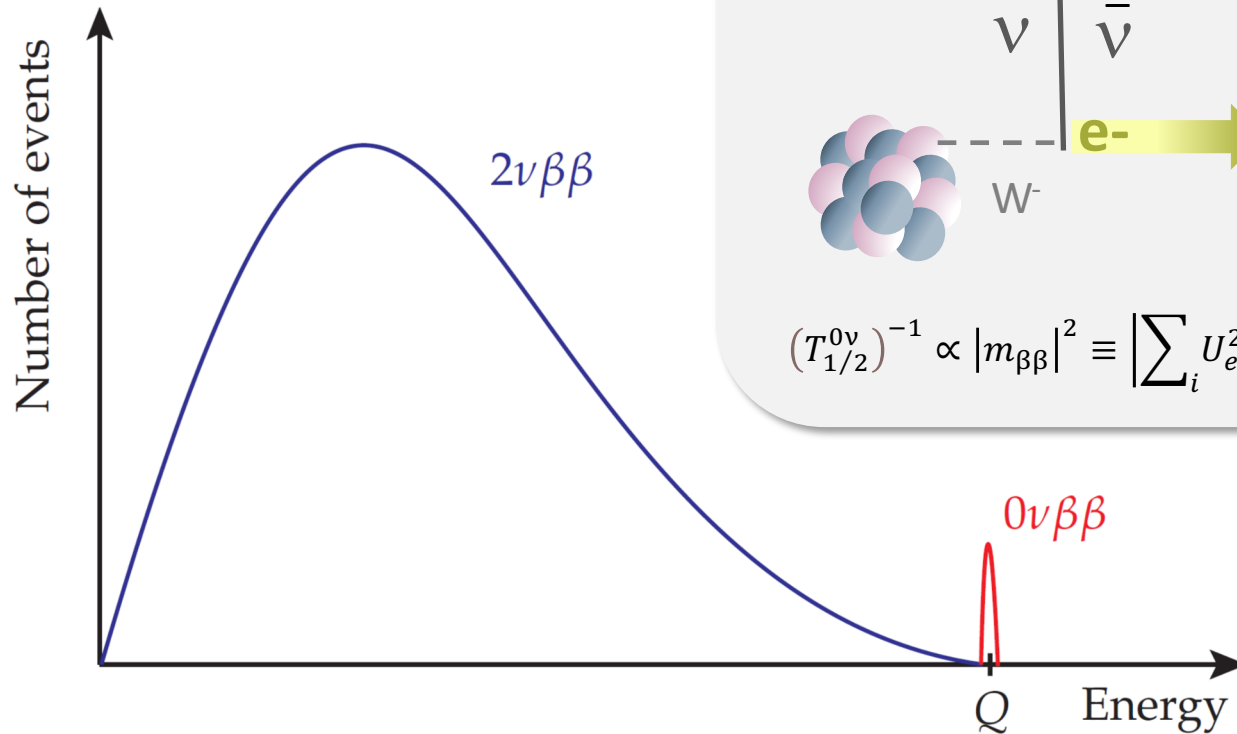

# My Contribution to the GERDA Experiment

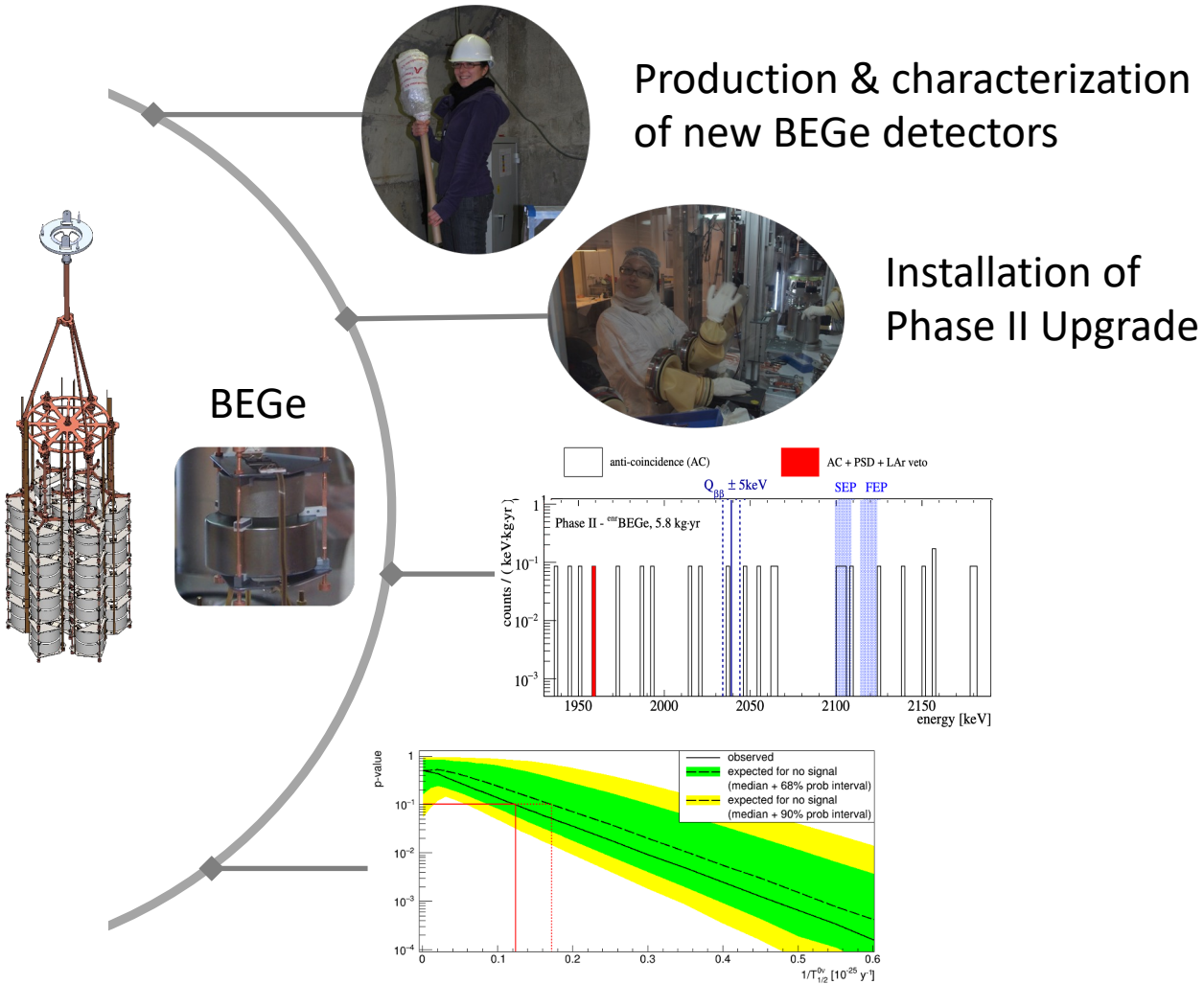

- GERDA achieved unprecedented background

$$\text{BI} = 5.2 \cdot 10^{-4} \frac{\text{counts}}{\text{keV} \cdot \text{kg} \cdot \text{yr}}$$

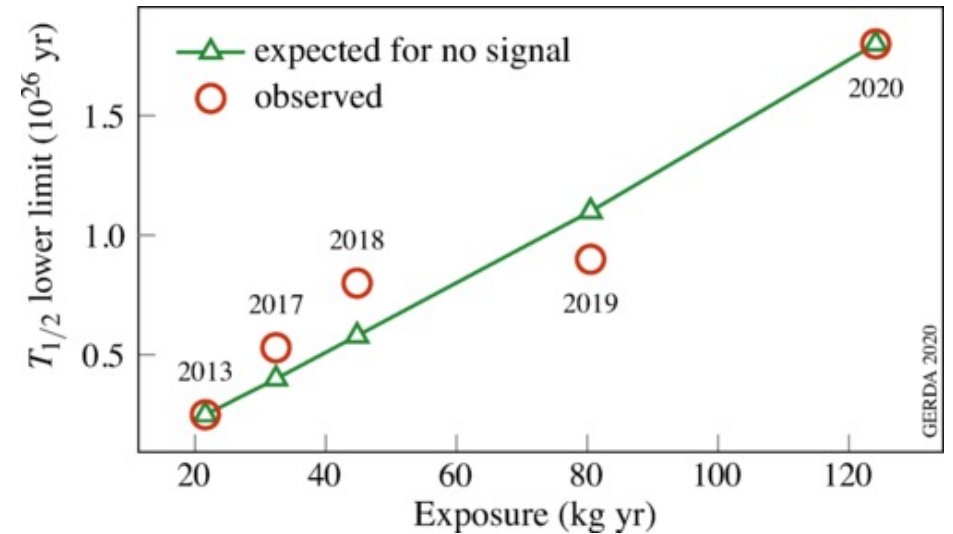

Phys. Rev. Lett. **125**, 252502

# Outline



SAPIENZA  
UNIVERSITÀ DI ROMA



TECHNISCHE  
UNIVERSITÄT  
MÜNCHEN



MAX-PLANCK-INSTITUT  
FÜR PHYSIK



2011-2017: My Past Research on Searching for Neutrinoless Double Beta Decay



Studying CEvNS with the NUCLEUS Experiment



Calibrating sub-keV nuclear recoils



Outlook



# Coherent Elastic Neutrino-Nucleus Scattering (CEvNS)

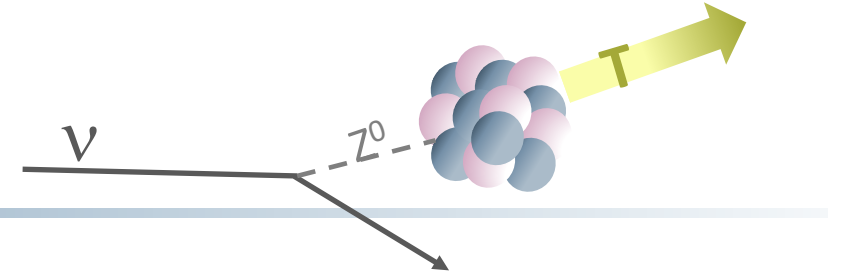

- Well-predicted within Standard Model:

$$\frac{d\sigma}{dT} = \frac{G_F^2 M}{4\pi} \underbrace{[Z(1 - 4\sin^2\theta_w) - N]^2}_{\text{weak charge}} \underbrace{\left(1 - \frac{MT}{2E_\nu^2}\right)}_{\text{kinematics}} \underbrace{F_w^2(q^2)}_{\text{weak form factor}}$$

- Coherent process for  $q < 1/r_n$
- Large cross-section compared to other  $\nu$ -interactions
- Flavor blind interaction
- Dominant  $\nu$ -scattering process for  $E_\nu < 50$  MeV**

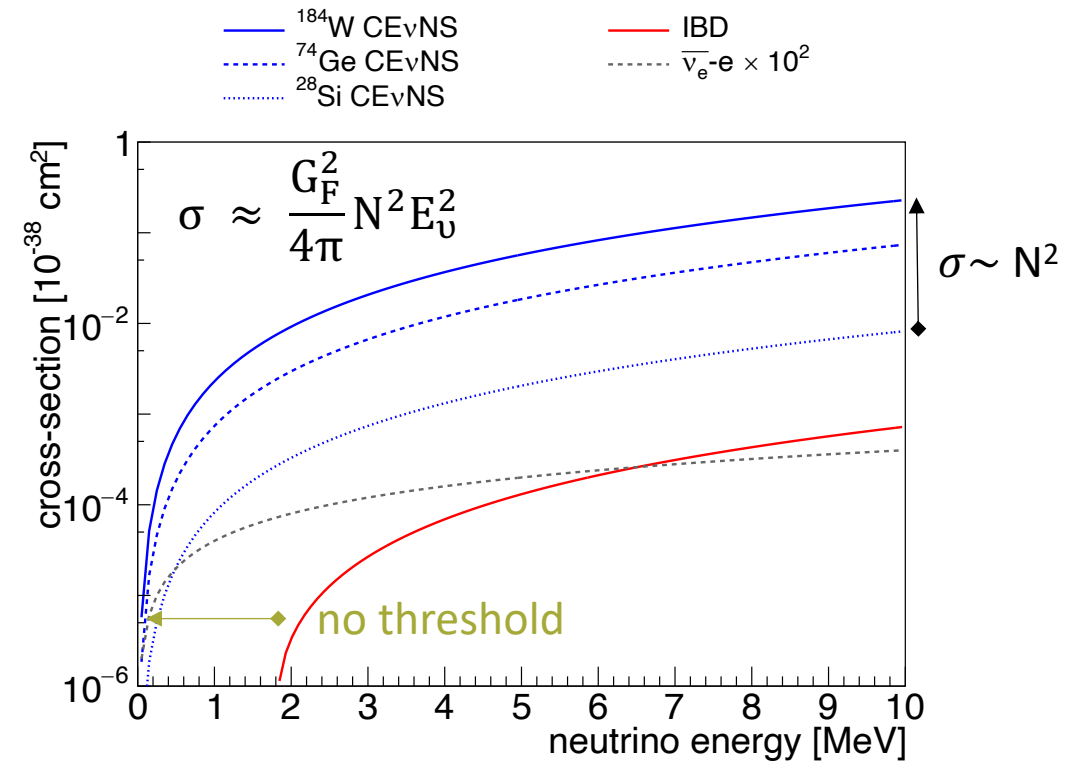

# CEvNS Potential - Physics

- Complementary measurement of the weak neutral current
- Precision test of the **Standard Model**
- Physics **beyond the Standard Model**, e.g.:
  - new  $\nu$ -quark couplings
  - new mediators
  - neutrino magnetic moment
- New channel for **sterile neutrino searches**, **solar physics** and **supernovae detection**
- **Neutrino fog**: (irreducible) background for Dark Matter experiments
- Application in **nuclear and stellar collapse physics** (Type II SN), **reactor monitoring**

$$\sigma \sim \left[ Z \left( g_V^p + 2\varepsilon_{\alpha\alpha}^{uV} + \varepsilon_{\alpha\alpha}^{dV} \right) + N \left( g_V^n + \varepsilon_{\alpha\alpha}^{uV} + 2\varepsilon_{\alpha\alpha}^{dV} \right) \right]^2$$

$$g_V^p = +\frac{1}{2} - 2 \sin^2 \theta_W \quad g_V^n = -\frac{1}{2}$$

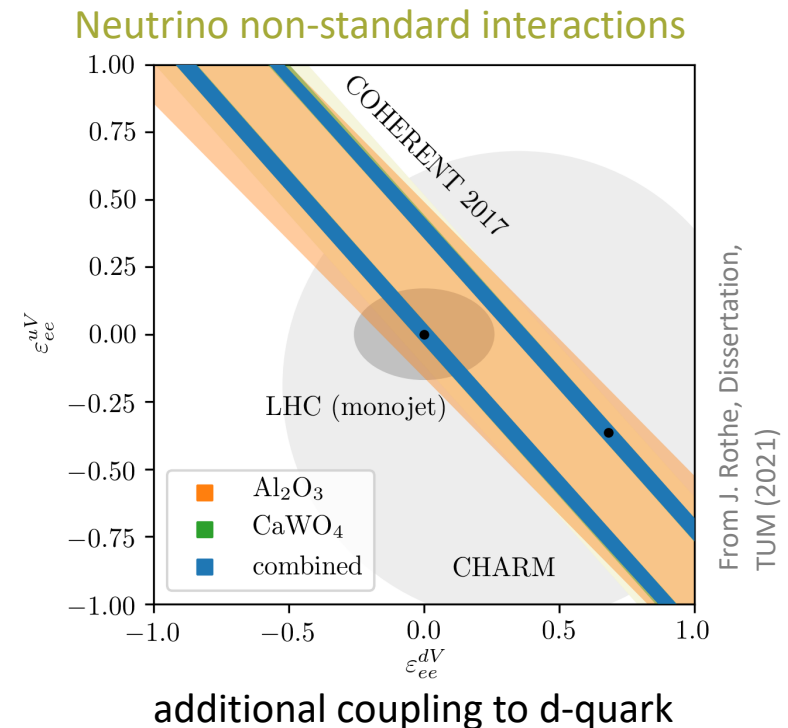

# Neutrino Sources for CEvNS

used by experiments these days

- **Dominant  $\nu$ -scattering process for  $E_\nu < 50$  MeV**

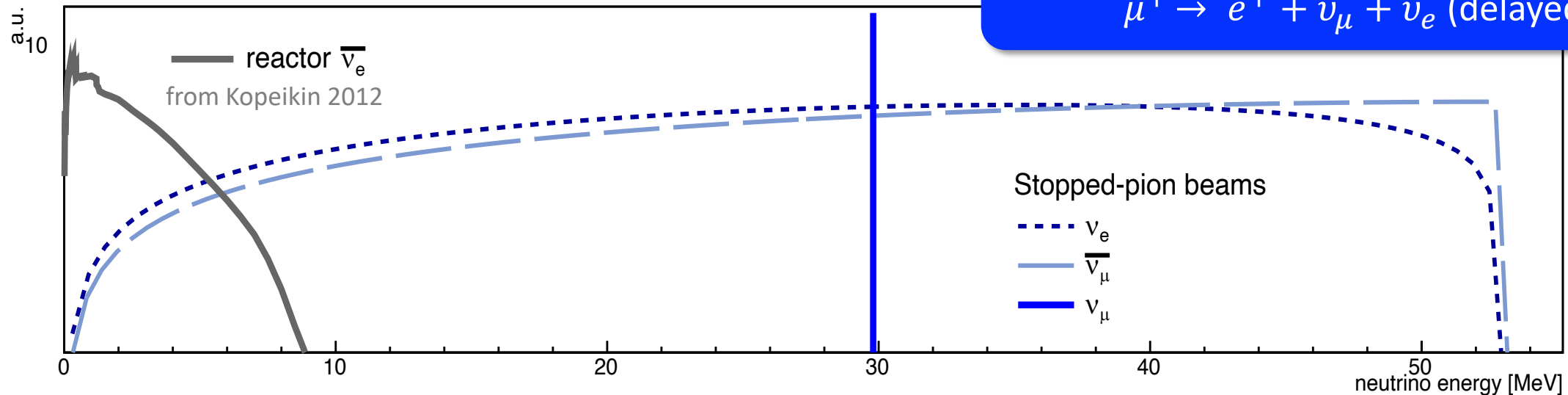

$$\pi^+ \rightarrow \mu^+ + \nu_\mu \text{ (prompt)}$$

$$\mu^+ \rightarrow e^+ + \bar{\nu}_\mu + \nu_e \text{ (delayed)}$$

- **High flux:**  $O(10^{12} \text{ v/s})$  @ power reactors ( $\sim 40\text{m}$ )
- Low neutrino energy ( $\sim 3$  MeV): **coherency**

- Flux at SNS in Oakridge (US):  $4.3 \times 10^7 \text{ v}/(\text{cm}^2 \text{ s})$
- **High neutrino energy:** start of incoherence

# The CEvNS Signature

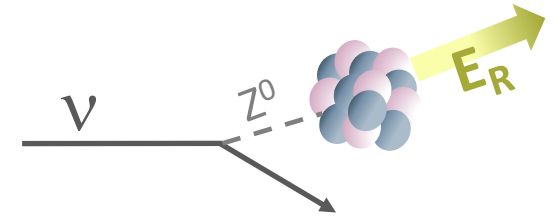

Recoil spectrum for  $^{74}\text{Ge}$

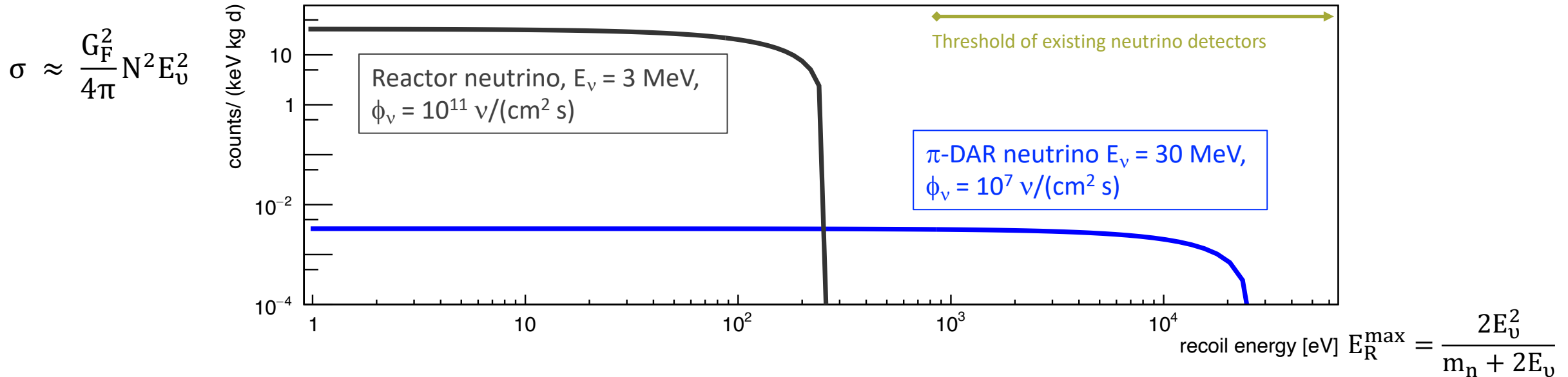

- **High flux:**  $O(10^{12} \text{ v/s})$  @ power reactors ( $\sim 40\text{m}$ )
- Low neutrino energy ( $\sim 3 \text{ MeV}$ ): **coherency**
- Needs sophisticated (active) shielding

- Flux at SNS in Oakridge (US):  $4.3 \times 10^7 \text{ v}/(\text{cm}^2 \text{ s})$
- **High neutrino energy:** start of incoherence
- **Background** rejection from timing analysis

# CEvNS Experiments

More complete list e.g. arXiv:2203.07361

- Reactor neutrinos
- Neutrino beams
- Future experiments

✓ COHERENT: results on CsI & Ar  
 ⚙️ Reactor experiment set limits on CEvNS (so far)

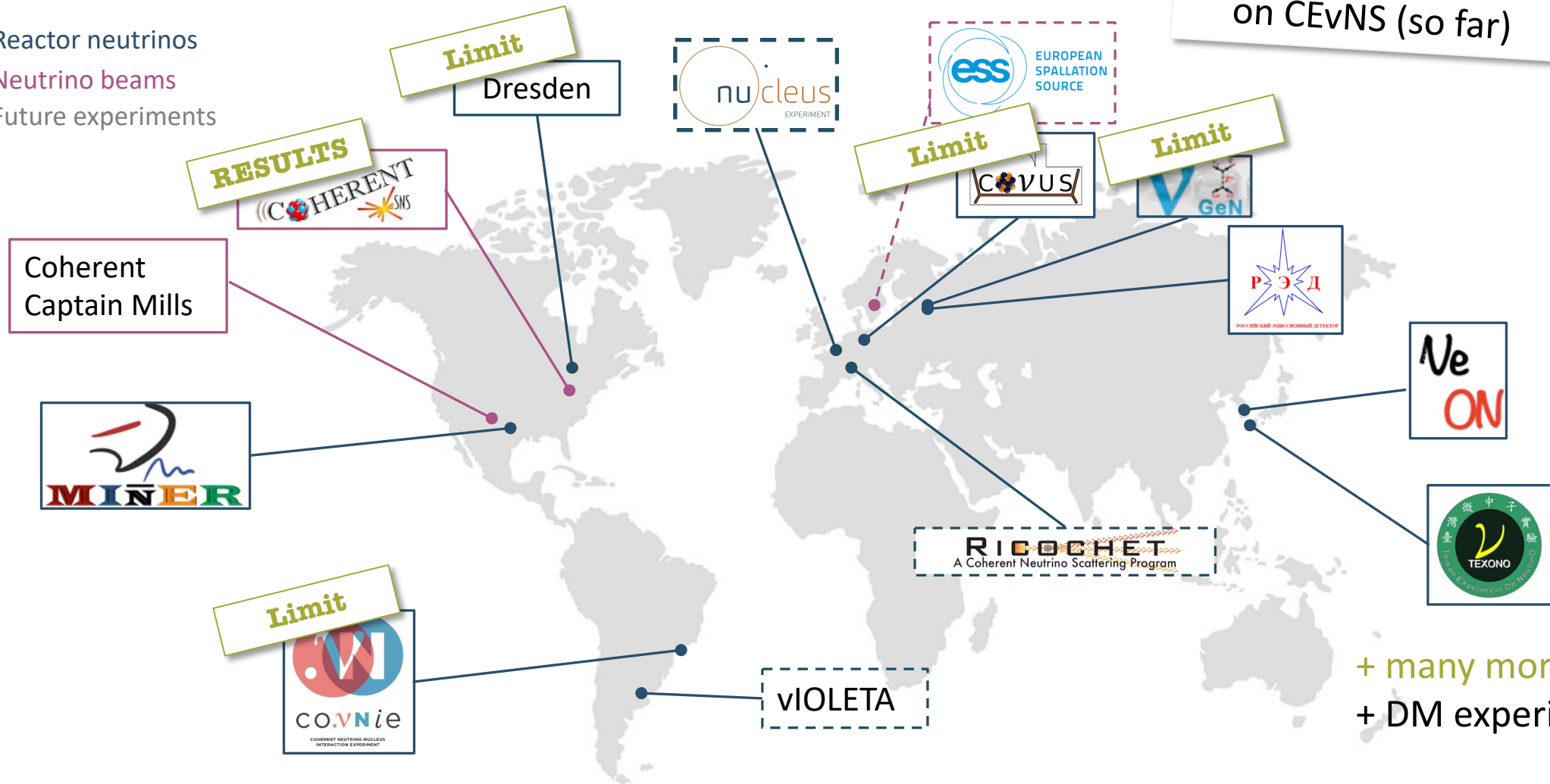

+ many more ideas  
 + DM experiments

# The Magnificent CEvNS Workshop Series

<https://indi.to/J9jWv>



MUNICH 2027



TU Munich



March 2023



Munich

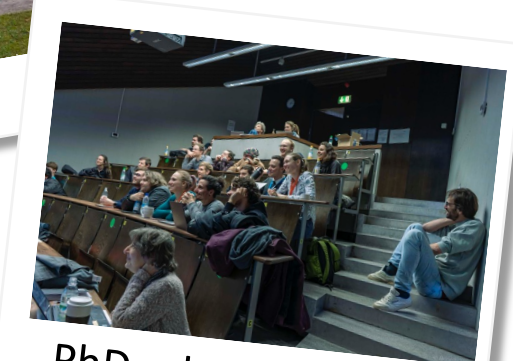

PhD school

# Next: Study $N^2$ and Energy Dependence of CEvNS

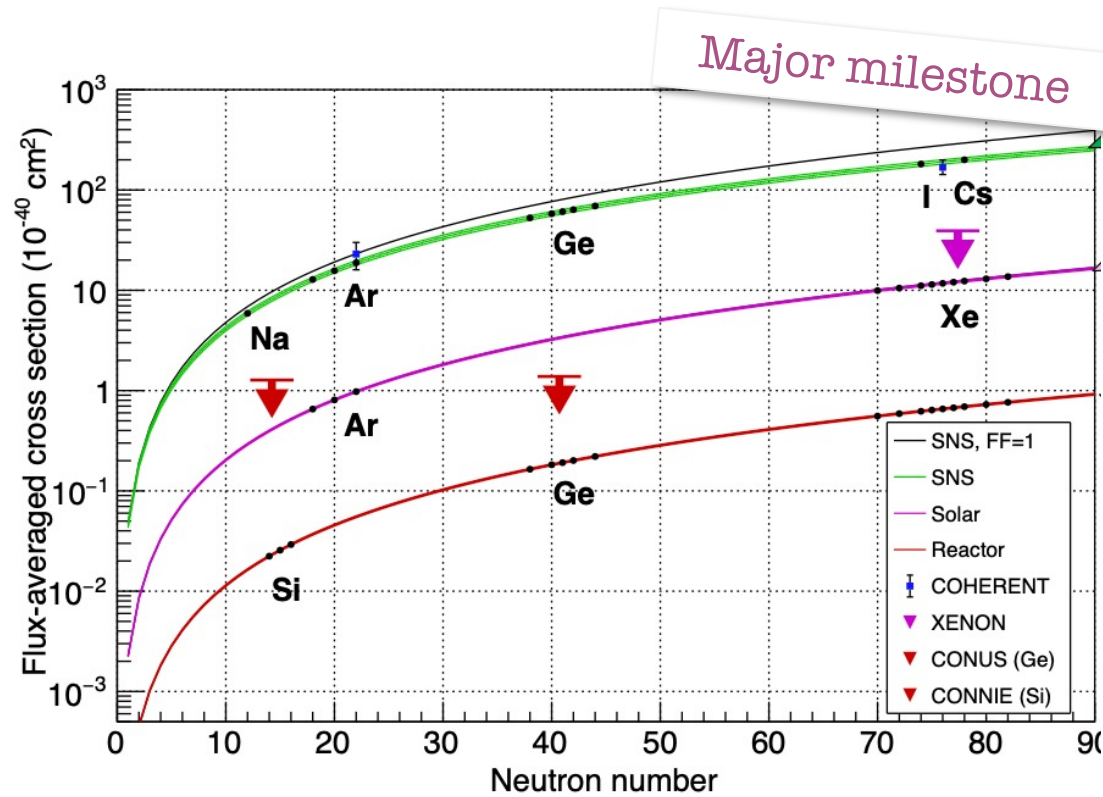

taken from K. Scholberg, talk at PANIC 2021

Source	Publication
Stopped $\pi$ -DAR source	<i>Phys.Rev.Lett.</i> 129 (2022) 8, 081801 (Cs) <i>Phys.Rev.Lett.</i> 126 (2021) 1, 012002 (Ar)
$^8\text{B}$ solar neutrinos	<i>Phys.Rev.Lett.</i> 126 (2021) 091301 (XENON)
Reactor neutrinos ( $\sim 3 \text{ MeV}$ )	<i>Phys. Rev. Lett.</i> <b>126</b> , 041804 (CONUS) <i>Phys.Rev.D</i> 106 (2022) 5, L051101 (vGen) <a href="#">2202.09672</a> [hep-ex] (DRESDEN) <i>JHEP</i> 04 (2020) 054 (CONNIE)



# Reactor Experiments

- Scale up target mass
- Reduce background
- Higher  $\nu$ -flux
- Reduce threshold

Experiment	Detector	Energy threshold	Status
CONUS	Ge ionization	O(1keV <sub>nr</sub> )	Finished Upgrade
TEXONO	Ge ionization	O(1keV <sub>nr</sub> )	Finished
Nu-GEN	Ge ionization	O(1keV <sub>nr</sub> )	Running
Dresden	Ge ionization	O(1keV <sub>nr</sub> )	Running
NEON	NaI(Tl) ionization	O(1keV <sub>nr</sub> )	Running
RED-100	Liquid Xe TPC	O(1keV <sub>nr</sub> )	Construction
CONNIE	CCD (Si)	~300eV <sub>nr</sub>	Running
MINER	Cryogenic (Ge, Si)	O(100eV <sub>nr</sub> )	Commissioning
RICOCHET	Cryogenic (Ge, Zn)	55eV <sub>nr</sub>	Construction
NUCLEUS	Cryogenic (CaWO <sub>4</sub> )	20eV <sub>nr</sub>	Construction

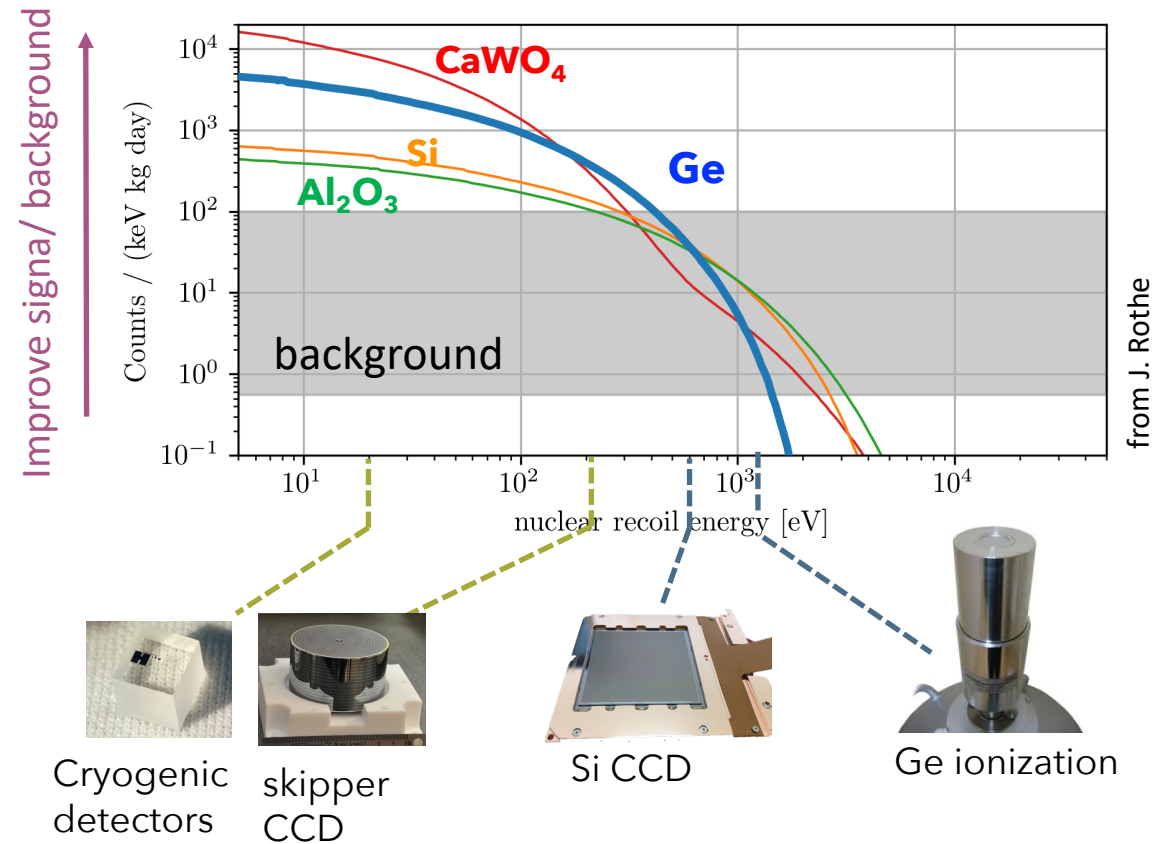

# Reactor Experiments



Experiment	Detector	Energy threshold	Status
CONUS	Ge ionization	O(1keV <sub>nr</sub> )	Finished Upgrade
TEXONO	Ge ionization	O(1keV <sub>nr</sub> )	Finished
Nu-GEN	Ge ionization	O(1keV <sub>nr</sub> )	Running
Dresden	Ge ionization	O(1keV <sub>nr</sub> )	Running
NEON	NaI(Tl) ionization	O(1keV <sub>nr</sub> )	Running
RED-100	Liquid Xe TPC	O(1keV <sub>nr</sub> )	Construction
CONNIE	CCD (Si)	~300eV <sub>nr</sub>	Running
MINER	Cryogenic (Ge, Si)	O(100eV <sub>nr</sub> )	Commissioning
RICOCHET	Cryogenic (Ge, Zn)	55eV <sub>nr</sub>	Construction
<b>NUCLEUS</b>	<b>Cryogenic (CaWO<sub>4</sub>)</b>	<b>20eV<sub>nr</sub></b>	<b>Construction</b>

**Reactor Sites**



CHOOZ, France

Power	4.25GW <sub>th</sub>
Cores	2
Baseline	72 , 102m
$\nu$ -flux	$2 \times 10^{12} \text{ cm}^{-2}\text{s}^{-1}$

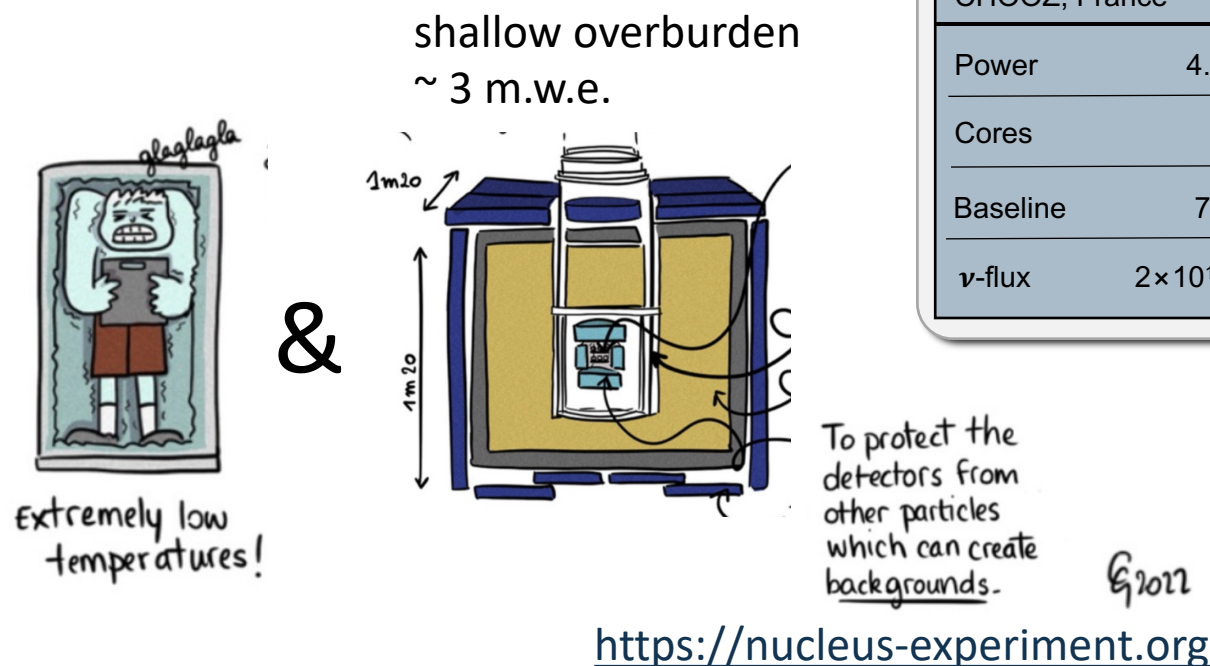

Lowest energy threshold for nuclear recoils  $E_{th} = (19.7 \pm 0.8) \text{ eV}$

Al<sub>2</sub>O<sub>3</sub> prototype, Phys. Rev. D 96, 022009 (2017)

# Principle of Cryogenic Detectors

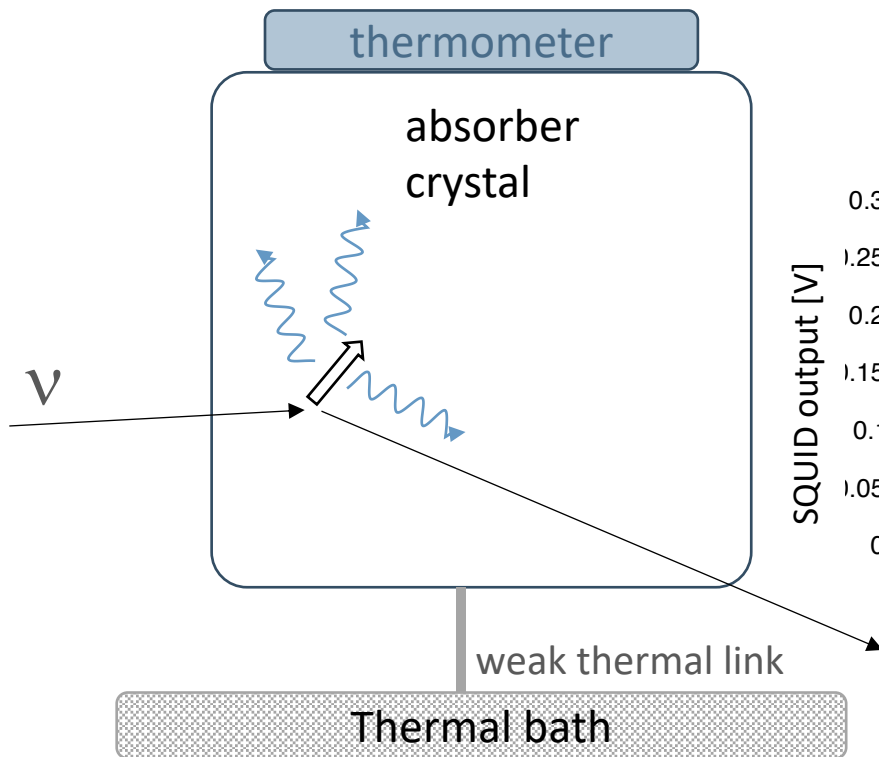

Heat pulse measured with tungsten transition edge sensors (W-TES)

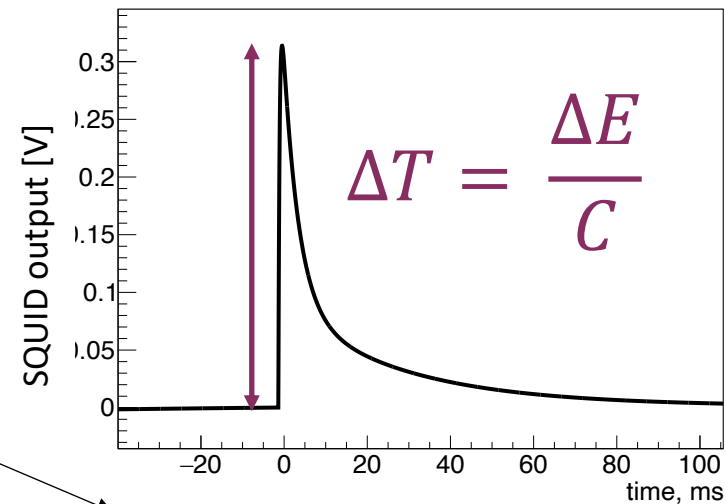

- ✓ Achieve very low thresholds & excellent energy resolution
- ✓ Measure full recoil energy
- ✓ Independent of particle type
- ✓ Wide range of target materials
- ✓ Synergy with light-dark matter search: NUCLEUS is based on CRESST technology

# Gram-scale Cryogenic Detectors

First tests yield promising performance:

- ✓ Baseline resolution below 10 eV
  - ✓ Operation above ground with low rate **O(0.1 Hz)**
  - ✓ Rise time < 0.5 ms
  - ✓ Decay time 15 ms
  - ✓ Calibrated based on LED pulses demonstrated
- } Crucial for operation above-ground  
& in coincidence with veto

W-TES

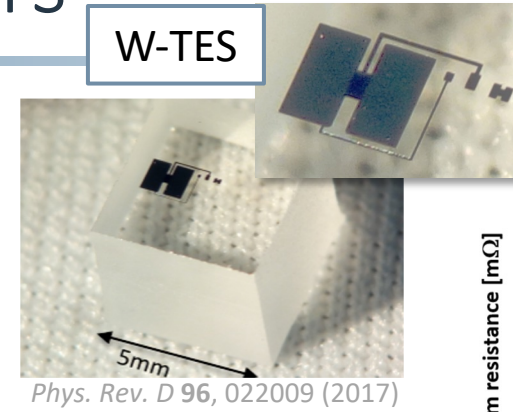

Transition of W-TES (developed by CRESST)

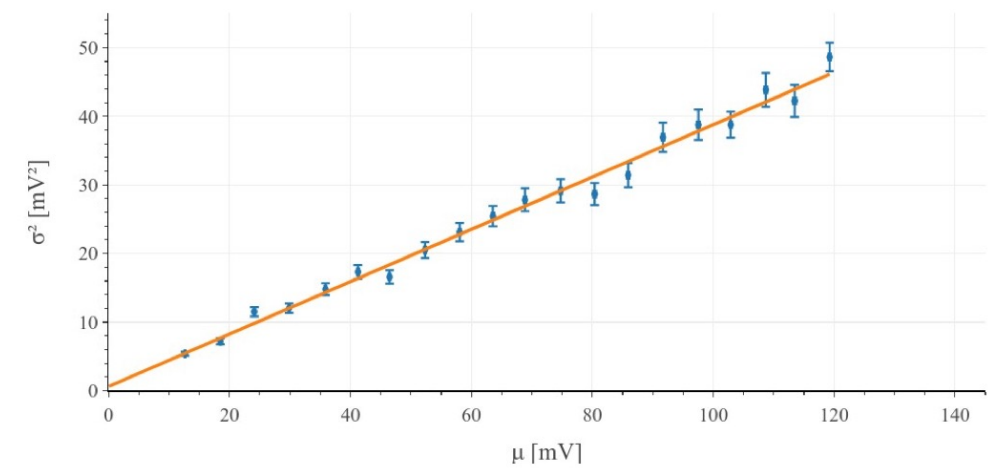
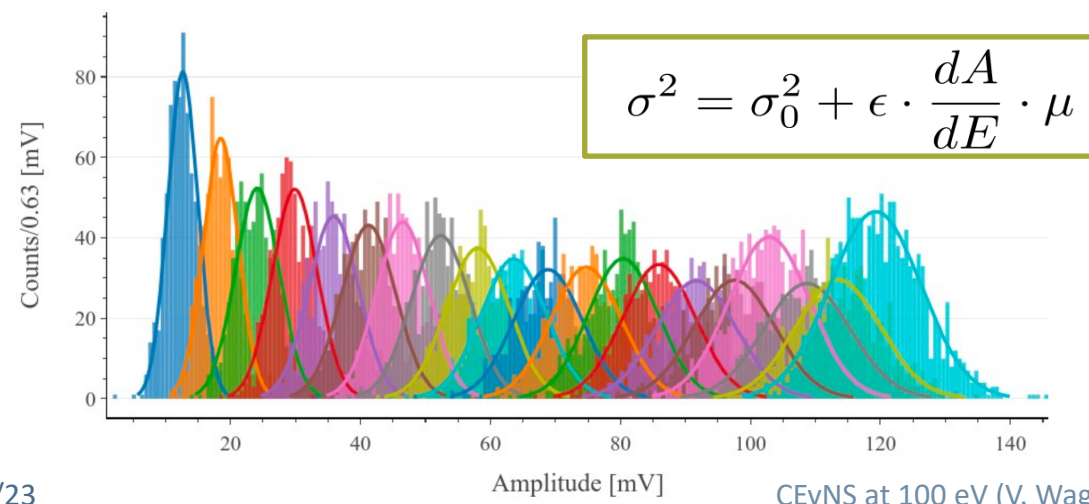
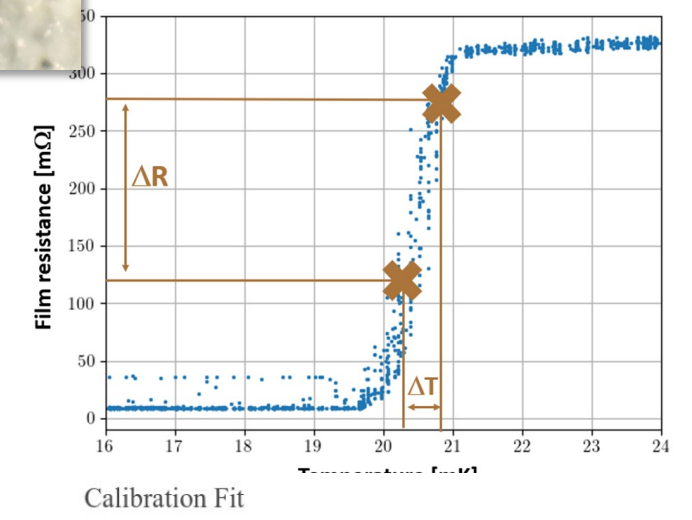

# Novel X-ray Calibration Source

- Extends typical  $^{55}\text{Fe}$  calibration down to 677 eV
- Study of the detector response
- Cross-calibration of LED system

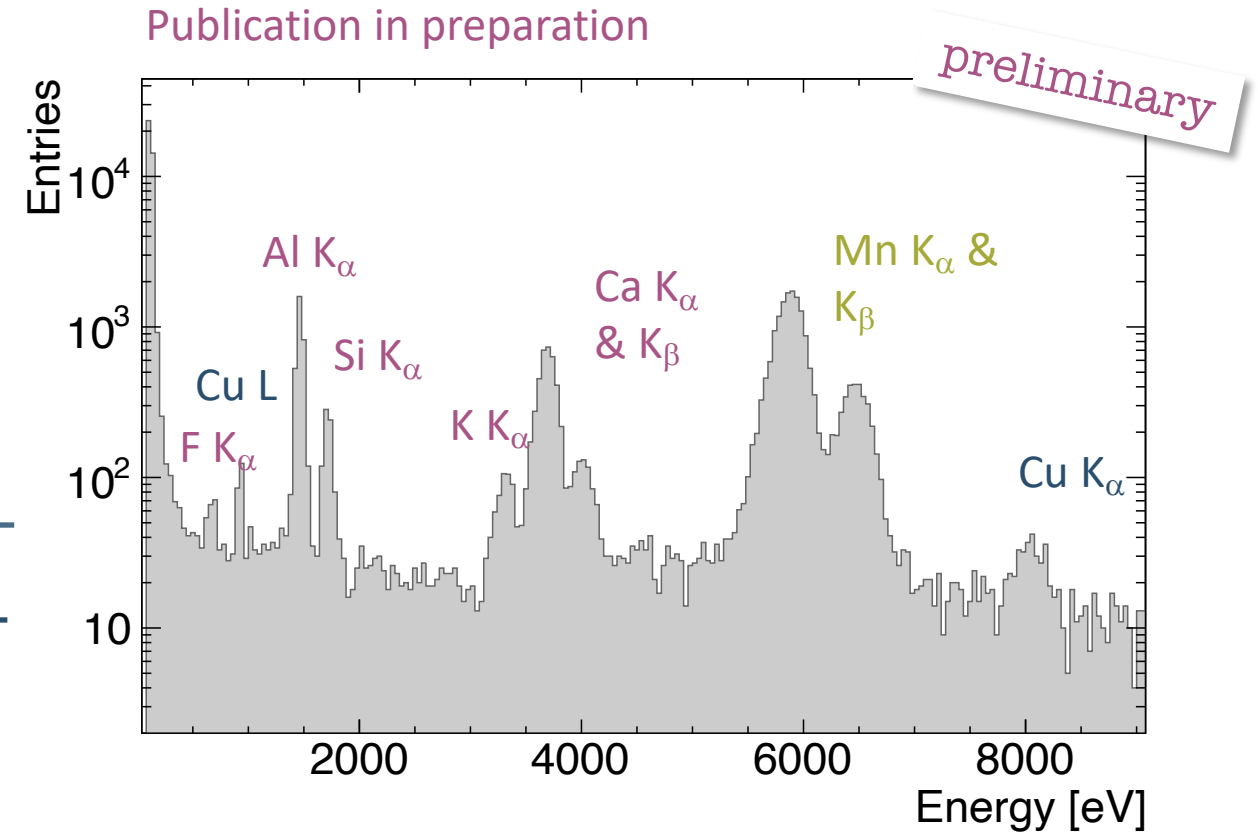
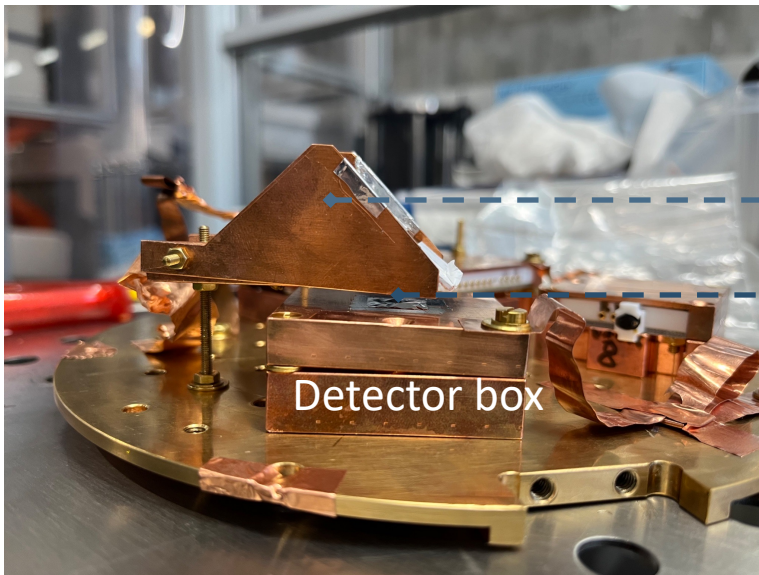

# The NUCLEUS Multi-target Approach & Background

## Target crystals:

Two 3x3 arrays with a total mass of 6g ( $\text{CaWO}_4$ ) + 4g ( $\text{Al}_2\text{O}_3$ )

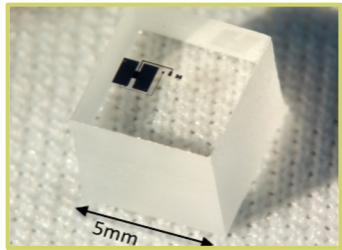

## Multi-target approach

- $\text{CaWO}_4$ : Background + CEvNS
- $\text{Al}_2\text{O}_3$ : Essentially background-only measurement

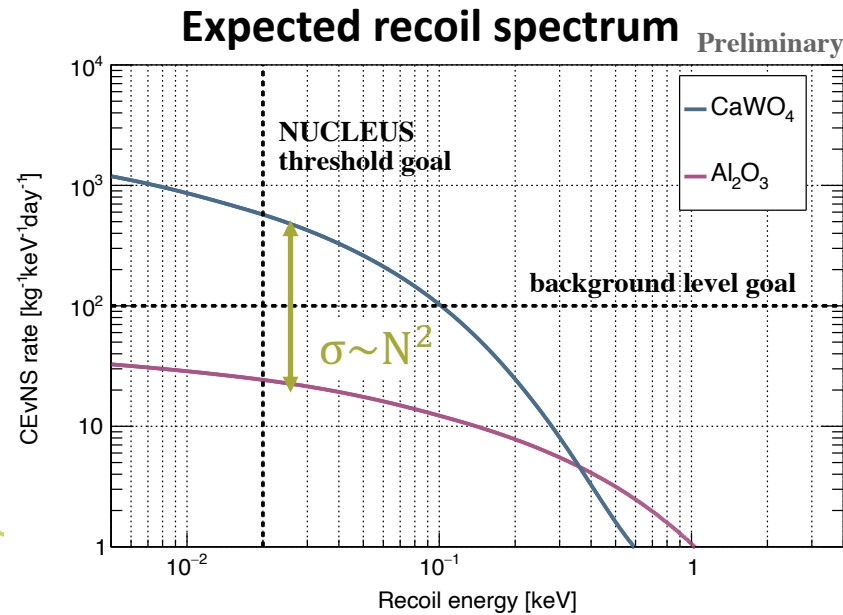

## Estimated rate budget in $\text{CaWO}_4$ (10-100 eV)

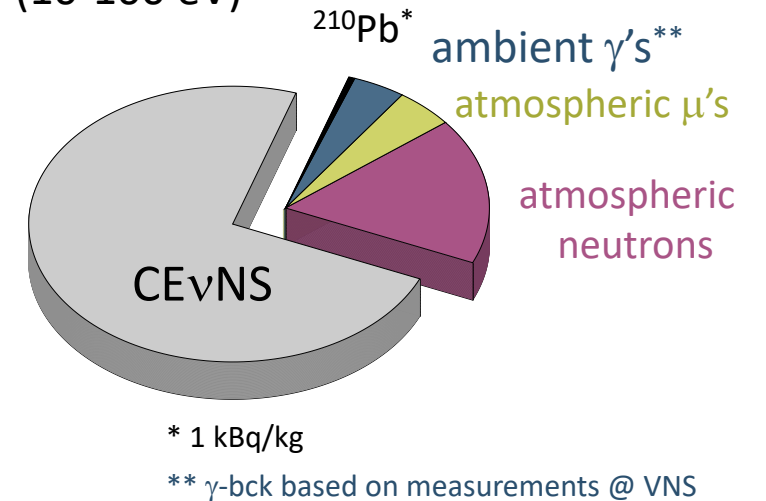

- ✓ Extensive GEANT4 simulations show that BI of 100 counts/ (keV kg d) is in reach

# The NUCLEUS Detector Concept

## Target crystals:

Two 3x3 arrays with a total mass of 6g ( $\text{CaWO}_4$ ) + 4g ( $\text{Al}_2\text{O}_3$ )

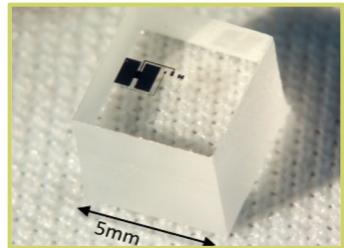

## Inner veto: TES-instrumented holder

to reject surface backgrounds and holder-related events

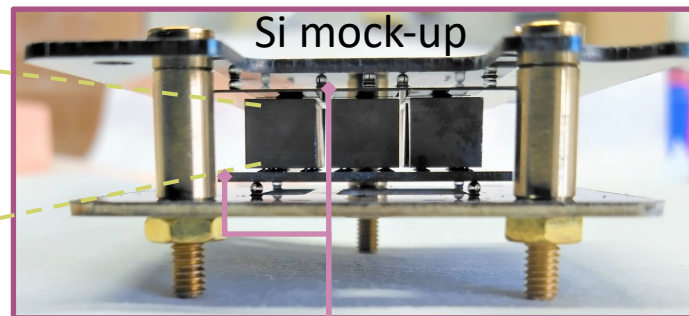

Si wafer  
+ W-TES

Germanium outer veto for active  $\gamma/n$  background rejection

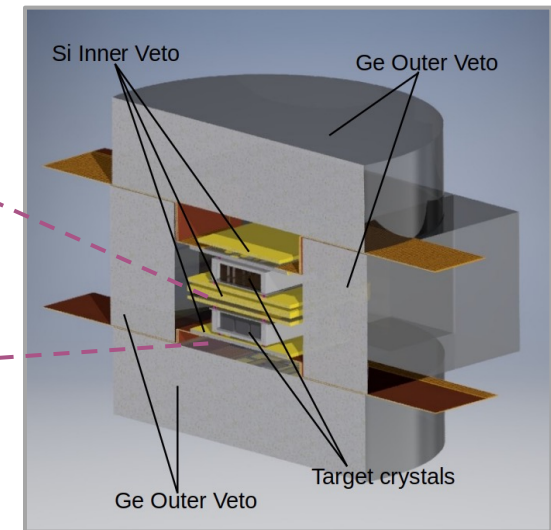

$4\pi$  HPGe ionization detector with  $E_{\text{thr}} < 10$  keV

# The NUCLEUS' Shielding

VW et al 2022 JINST 17 T05020

Optimized with extensive GEANT4 simulations and on-site background measurement to minimize muon-induced neutrons

- Compact shielding surrounding the cryostat (1.2 m x 1.2):
  - 5 cm lead
  - 20 cm 5%-borated polyethylene
  - 4 cm boron carbide
- At 3 m.w.e, a muon veto with  $\epsilon > 99\%$  is needed

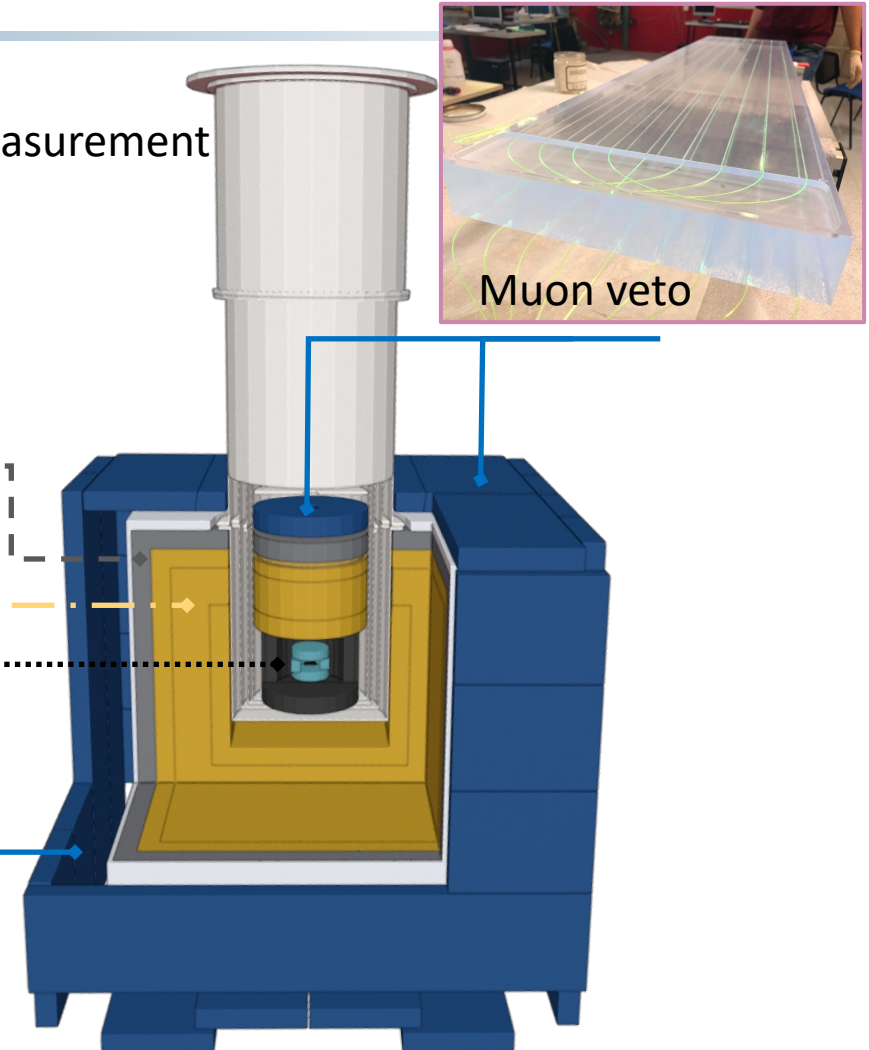

# The NUCLEUS' (Inner) Shielding

The active & passive shielding is continued inside the cryostat for  $4\pi$  coverage

- Successful cool-down of full inner shielding
- Pb, Cu, PE, B<sub>4</sub>C thermalized at 800 mK
- Cryogenic muon veto
  - Operation at sub-K temperatures shown
  - Increase of light output observed wrt. 300 K

<https://doi.org/10.1007/s10909-022-02842-5>

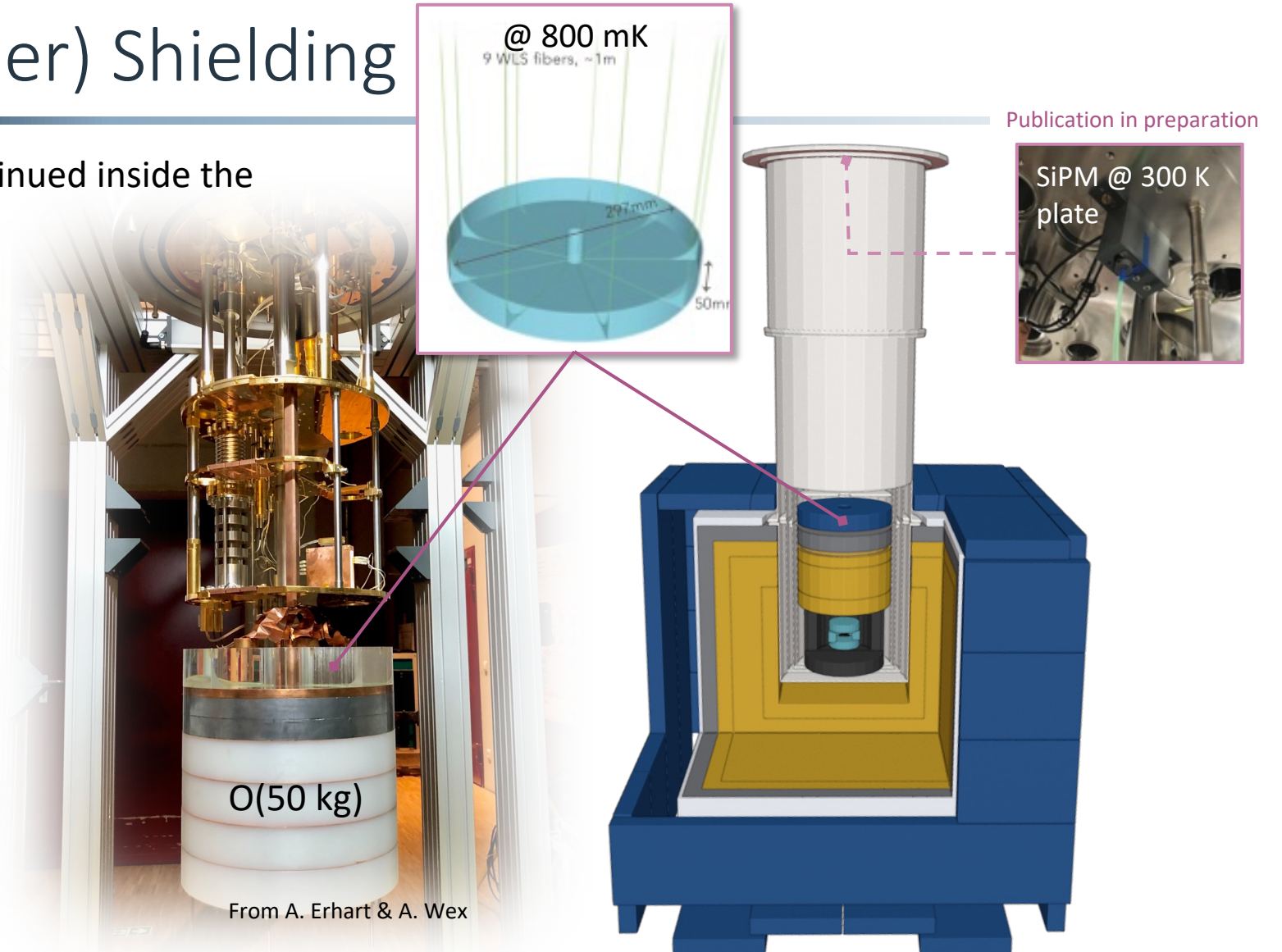

# NUCLEUS Current Status – Shielding Assembly

2023

Blank assembly & Commissioning



⊕ Performance of target & veto detectors

⊕ Full Calibration

⊕ Background characterization e.g. with cryo LiF



2024

On-site installation



✓ Full shielding assembled at TUM

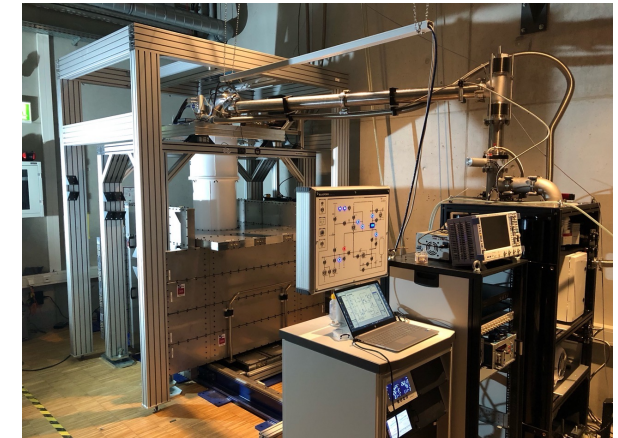
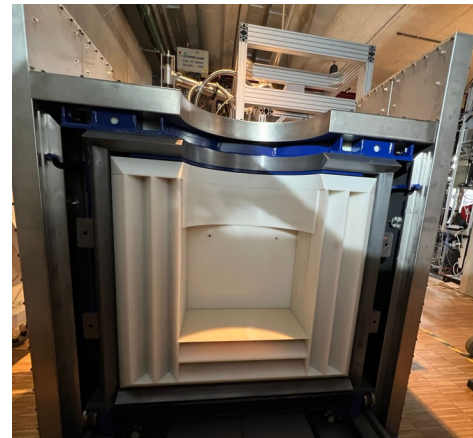
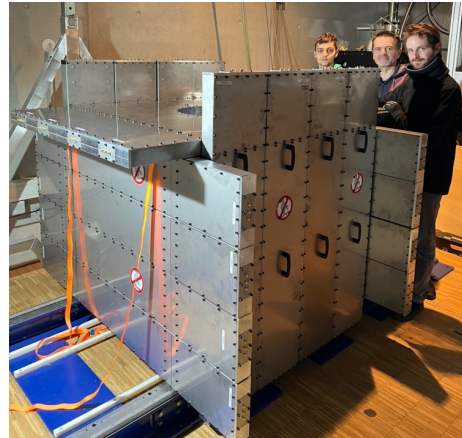
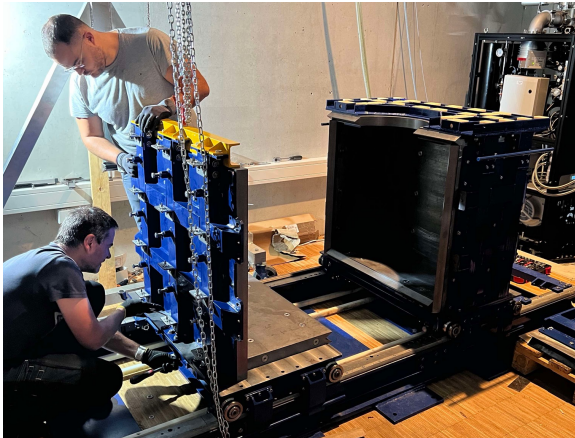

# NUCLEUS Schedule

2023

Blank assembly & Commissioning



⊕ Performance of target & veto detectors

⊕ Full Calibration

⊕ Background characterization



2024

On-site installation



2024

Physics Run  
NUCLEUS-10g

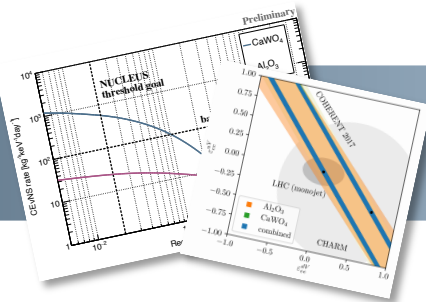

Towards  
NUCLEUS-1kg\*

\*new detector design

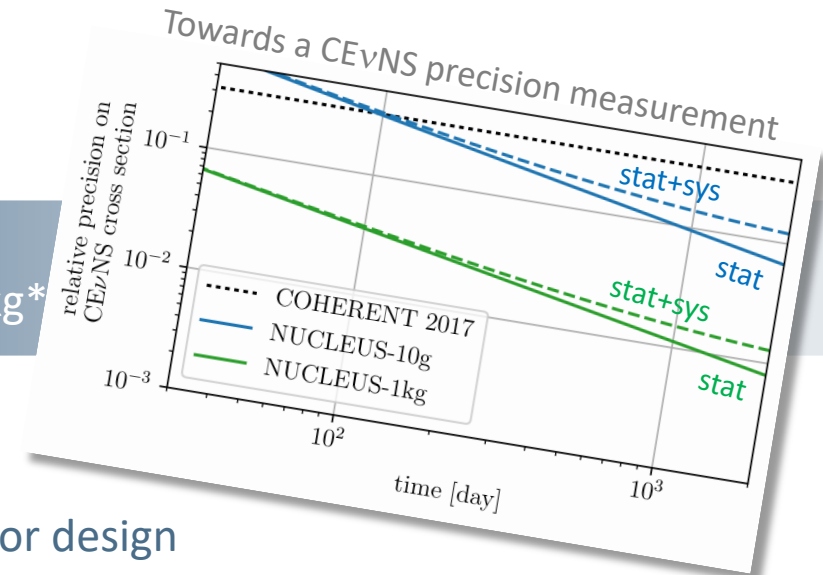

# Outline

Calibrated Recoils for  
Accurate Bolometry

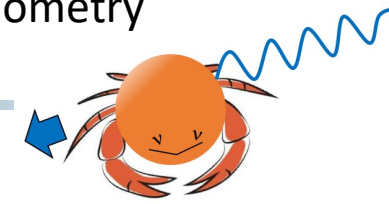

**Spokespersons:**  
D. Lhuillier (CEA),  
VW (TUM)



Introduction to CEvNS



Experimental efforts to study CEvNS



The NUCLEUS experiment



**Calibrating Sub-keV Nuclear Recoils**



Summary & Outlook

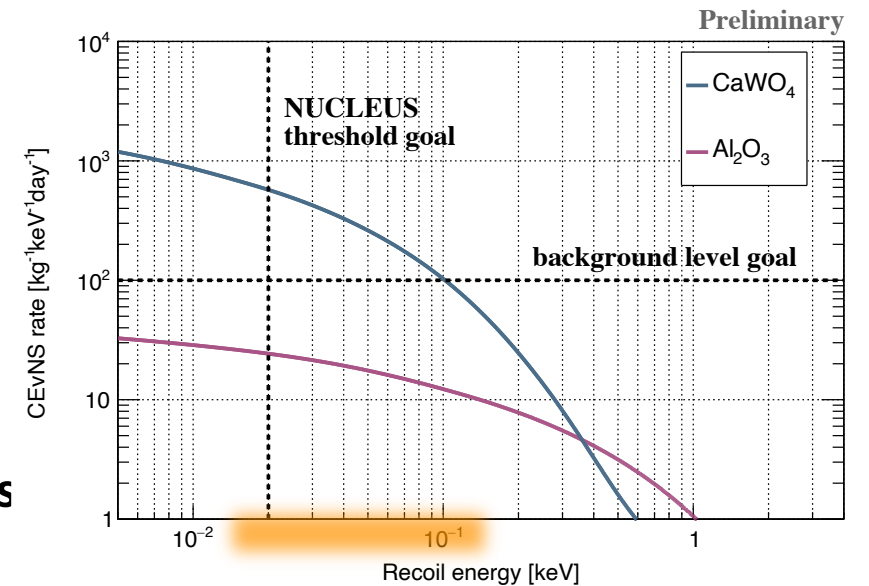

Light DM &

future CEvNS experiments

# The Need for Nuclear Recoil Calibration at 100 eV

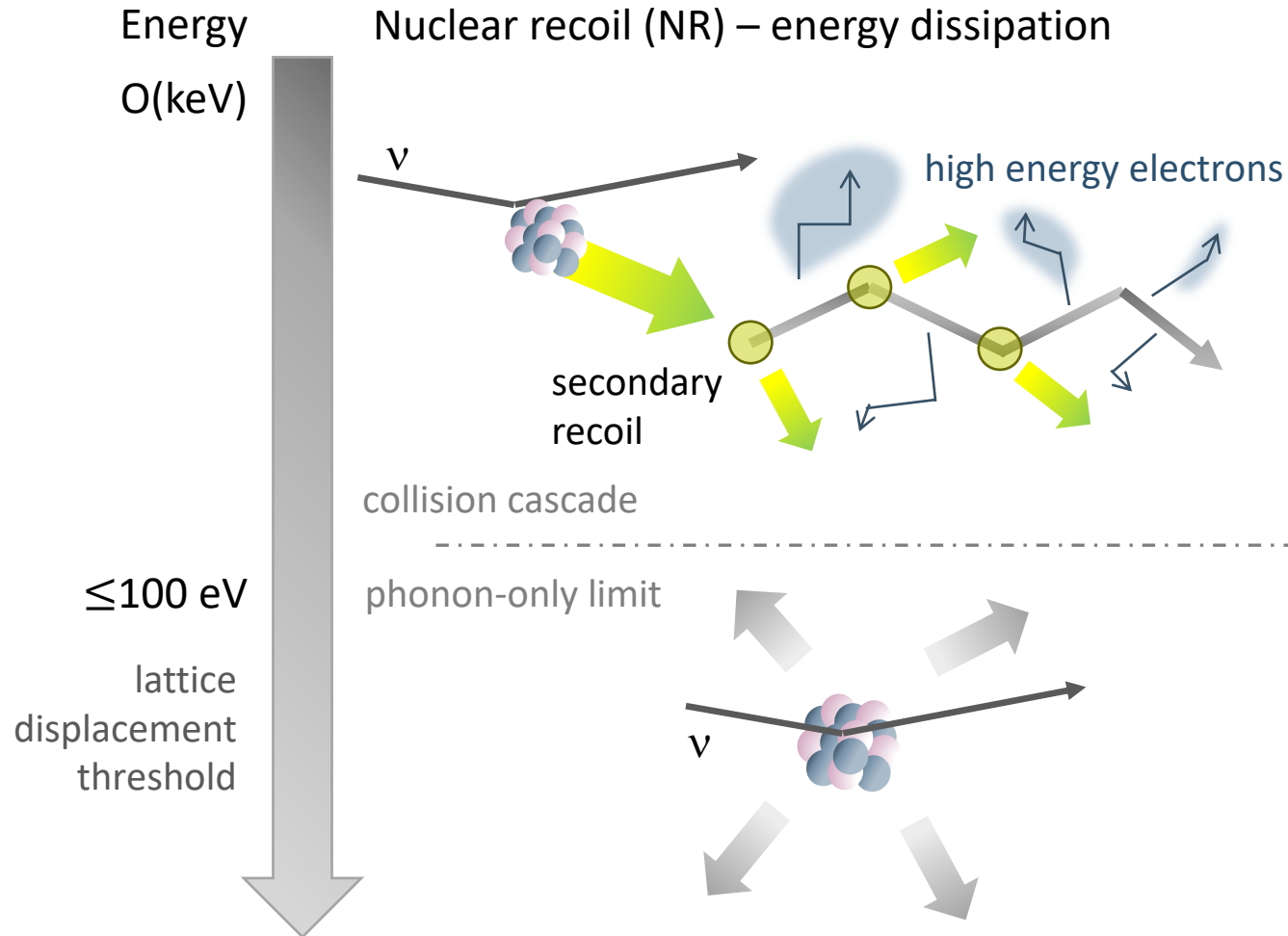

- ✓ Well understood energy dissipation
- ✓ Lindhard model valid in keV regime

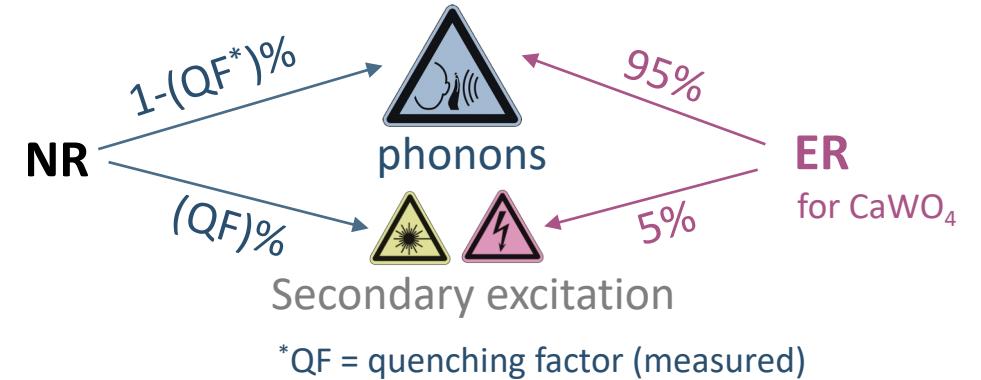

- Need model for energy dissipation including impact of lattice defects, orientation, etc.
- How do ER and NR compare?

Need for direct & independent calibration method for NR

# Calibration of Sub-keV NR

Calibrated **R**ecoils for  
Accurate **B**olometry

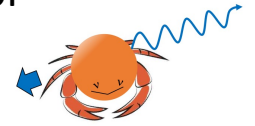

Novel Idea

based on L. Thulliez, D. Lhuillier *et al* 2021 *JINST* 16

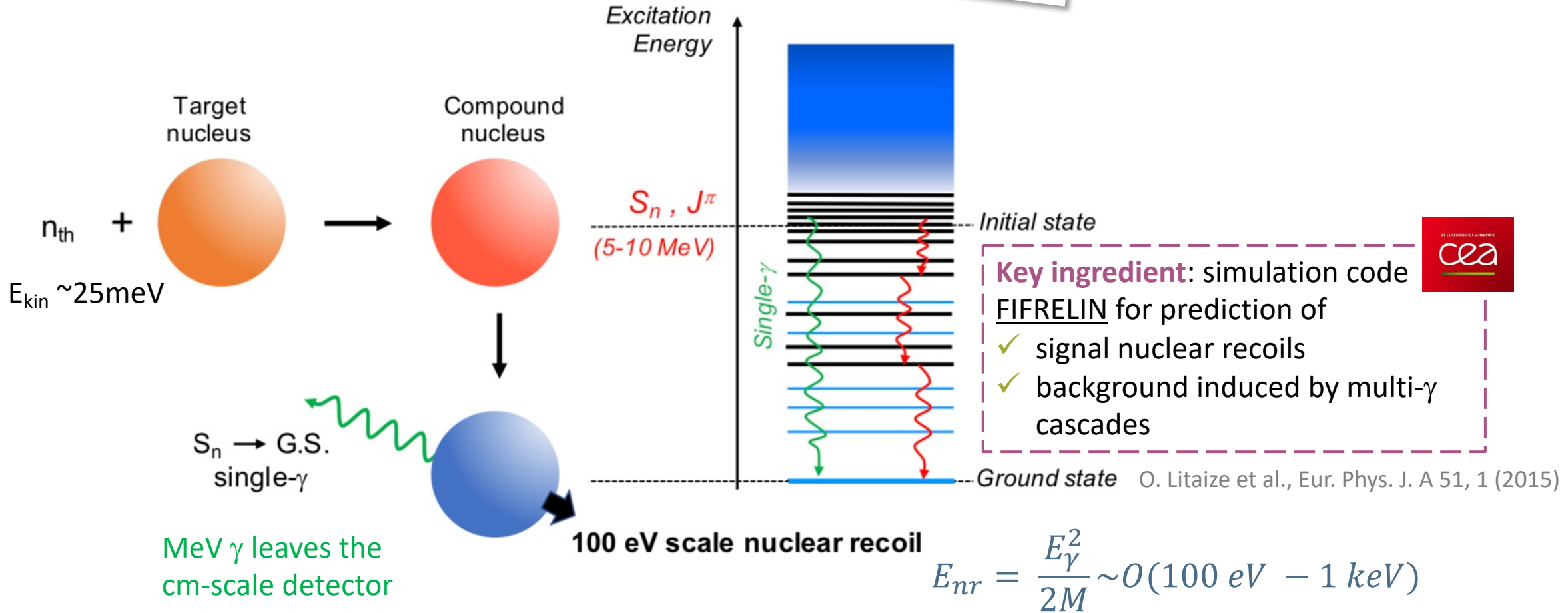

# Observation of a NR Peak at the 100 eV Scale Induced by Neutron Capture

- Continued 6 eV resolution over several days of measurement
- NR calibration observed around 100 eV with more than  $3\sigma$

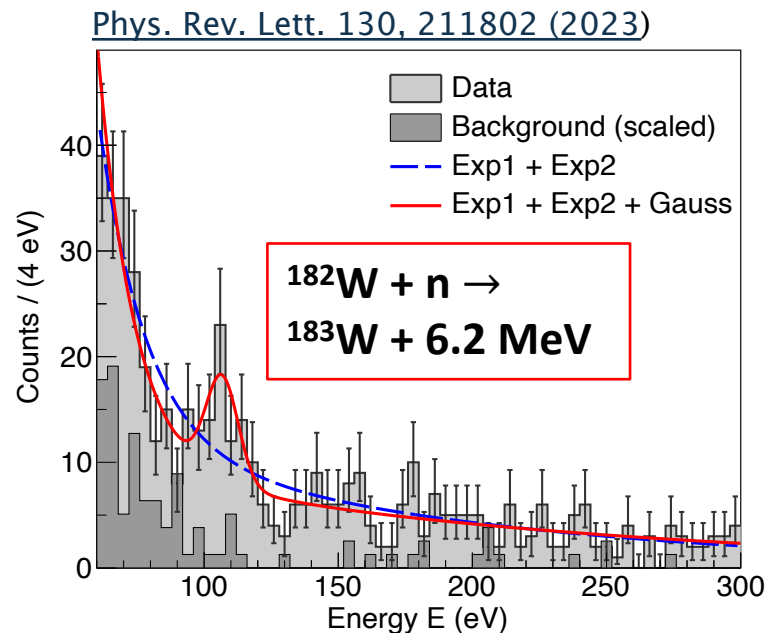

CaWO<sub>4</sub> cube held with copper clamps and sapphire balls

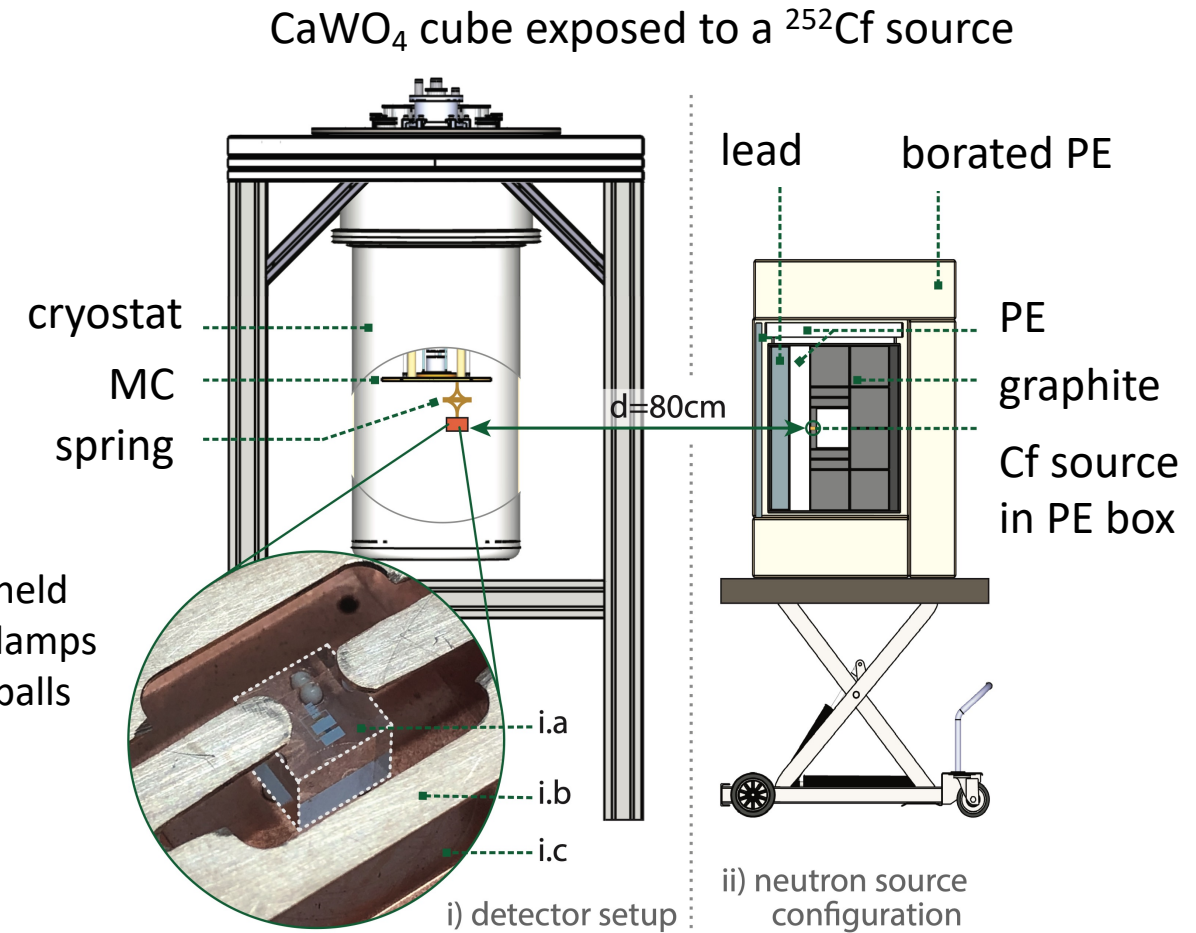

# Precision Calibration of $\text{CaWO}_4$

L. Thulliez, D. Lhuillier *et al* 2021 *JINST* 16

- ✓ Full MC simulation yield calibration lines at 112 eV and 160 eV for  $\text{CaWO}_4$

250 kW TRIGA reactor in Vienna provides a clean thermal neutron beam

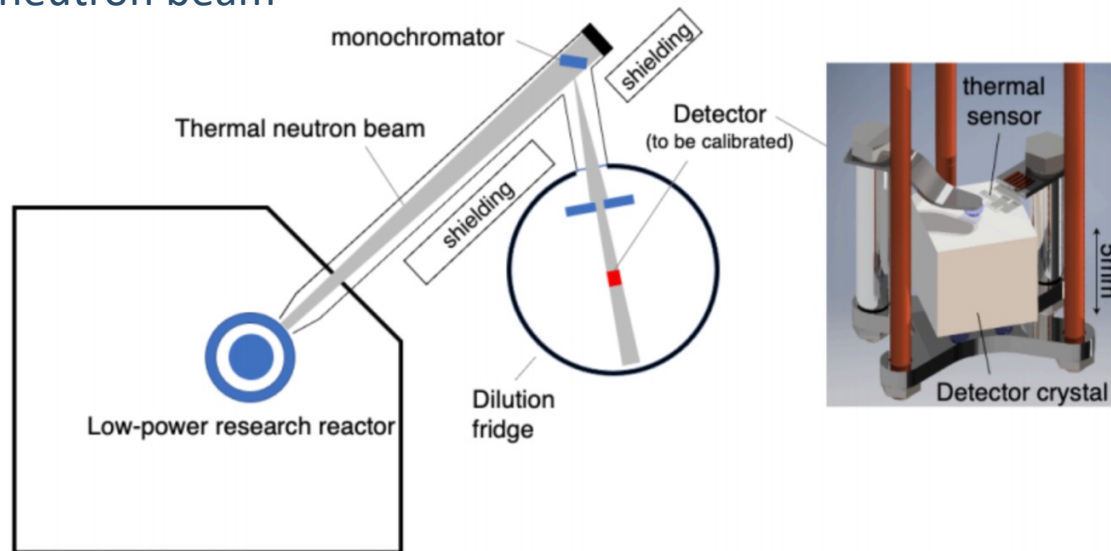

GEANT4 simulation for  
NUCLEUS 0.76 g  $\text{CaWO}_4$  crystal

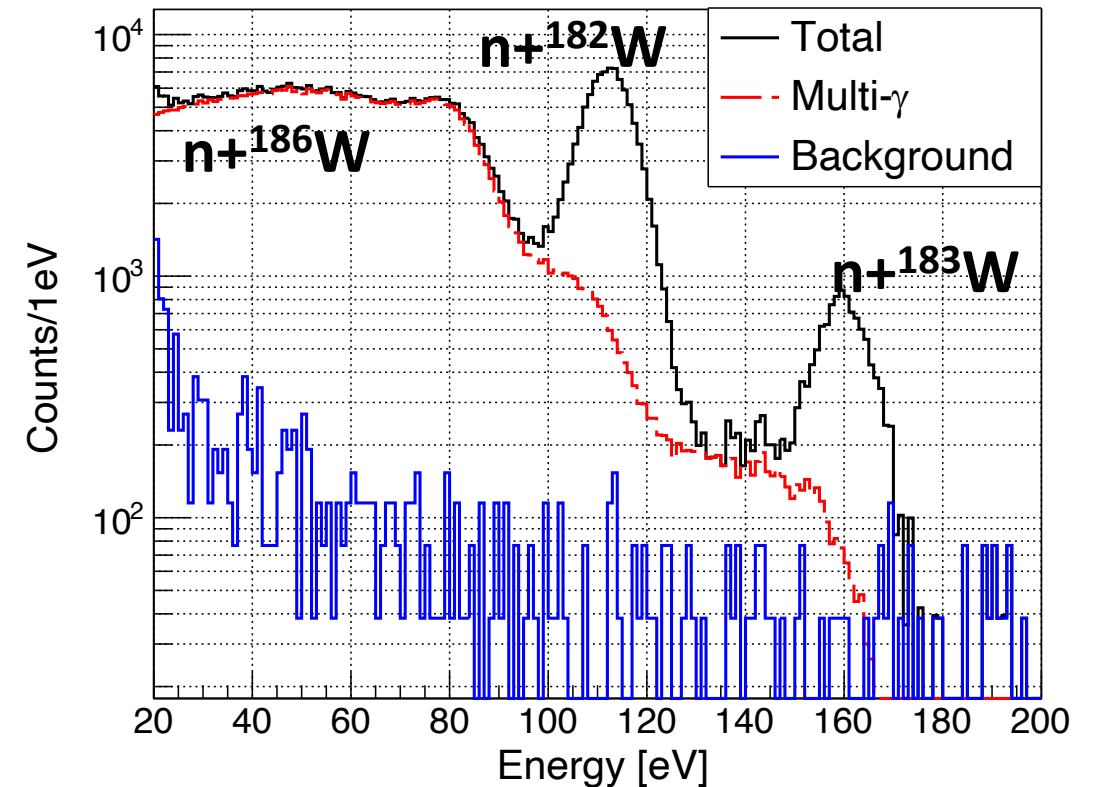

Background measured with NUCLEUS-1g  
*R. Strauss et al., Phys. Rev. D96, 022009 (2017)*

# Studying the Linearity of $\text{CaWO}_4$

L. Thulliez, D. Lhuillier *et al* 2021 *JINST* 16

- ✓ Full MC simulation yield calibration lines at 112 eV and 160 eV for  $\text{CaWO}_4$
- ✓ Coincident measurement of the emitted  $\gamma$ 's yields peak 85 eV
- ✓ Potential to tag even lower nuclear recoils

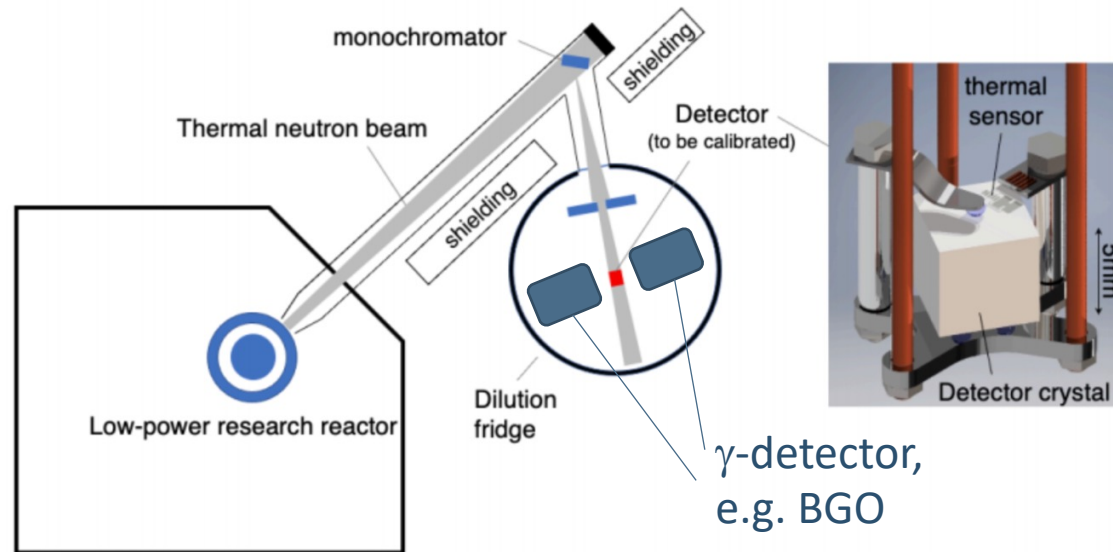

NUCLEUS 0.76 g  $\text{CaWO}_4$  crystal  
+  $(5.47 \pm 0.2)$  MeV coincidence

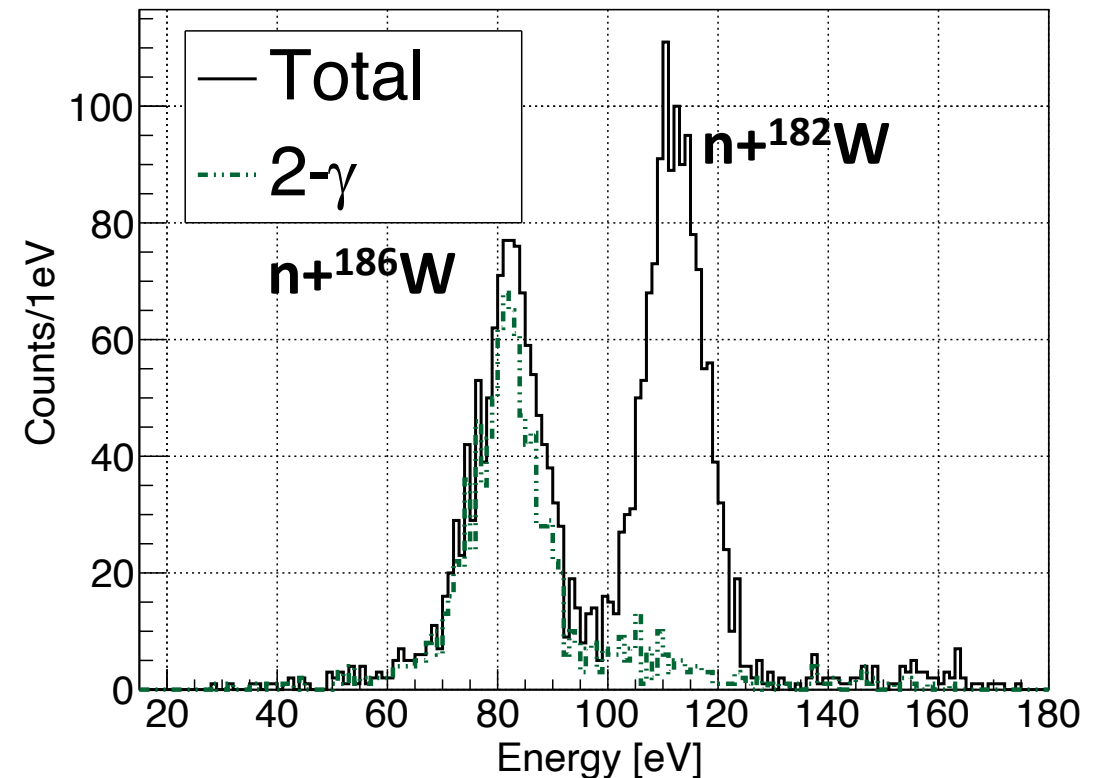

# Other Materials & Physics Potential

Target material	Target Isotope	Nuclear Recoil [eV]	F.O.M.*
CaWO <sub>4</sub>	<sup>182</sup> W	112.5	7506
	<sup>183</sup> W	160.3	823
	<sup>186</sup> W	85.8	281
Al <sub>2</sub> O <sub>3</sub>	<sup>27</sup> Al	1145	616
Si	<sup>28</sup> Si	1330	36
	<sup>28</sup> Si	989.9	118
Ge	<sup>70</sup> Ge	416.2	122
	<sup>74</sup> Ge	303.2	54

Linearity Study with three NR peaks

Strong single- $\gamma$  transition

Interesting double- $\gamma$  transition for timing studies

Quenching factor measurements

\* F.O.M. = nat. abundance \* s \* BR

# Quenching Factor Measurements

Highly relevant for ionization and cryogenic NTL-detectors

Target material	Target Isotope	Nuclear Recoil [eV]	F.O.M.*
CaWO <sub>4</sub>	<sup>182</sup> W	112.5	7506
	<sup>183</sup> W	160.3	823
	<sup>186</sup> W	85.8	281
Al <sub>2</sub> O <sub>3</sub>	<sup>27</sup> Al	1145	616
Si	<sup>28</sup> Si	1330	36
	<sup>28</sup> Si	989.9	118
Ge	<sup>70</sup> Ge	416.2	122
	<sup>74</sup> Ge	303.2	54

\* F.O.M. = nat. abundance \* s \* BR

[7.2-7.6] MeV coincidence

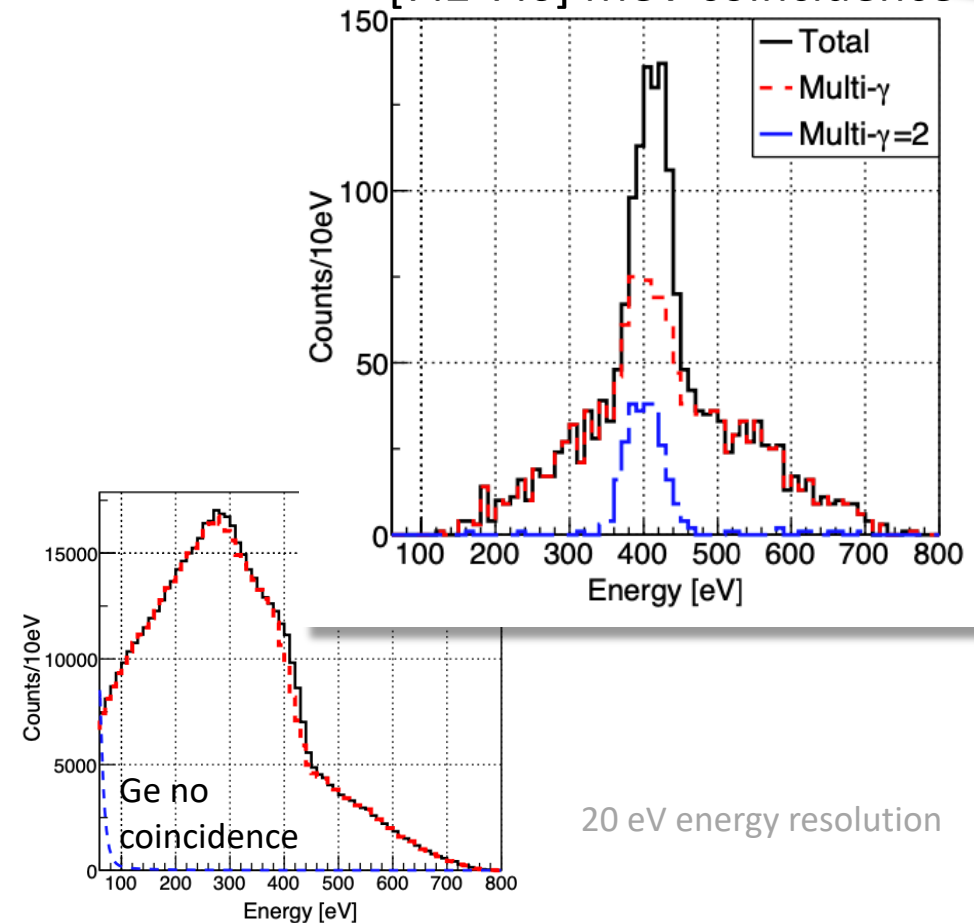

# Timing Effects

arXiv:2305.10139

Target material	Target Isotope	Nuclear Recoil [eV]	F.O.M.*
CaWO <sub>4</sub>	<sup>182</sup> W	112.5	7506
	<sup>183</sup> W	160.3	823
	<sup>186</sup> W	85.8	281
Al <sub>2</sub> O <sub>3</sub>	<sup>27</sup> Al	1145	616
Si	<sup>28</sup> Si	<b>1330</b>	<b>36</b>
	<sup>28</sup> Si	<b>989.9</b>	<b>118</b>
Ge	<sup>70</sup> Ge	416.2	122
	<sup>74</sup> Ge	303.2	54

\* F.O.M. = nat. abundance \* s \* BR

Probe underlying solid-state physics

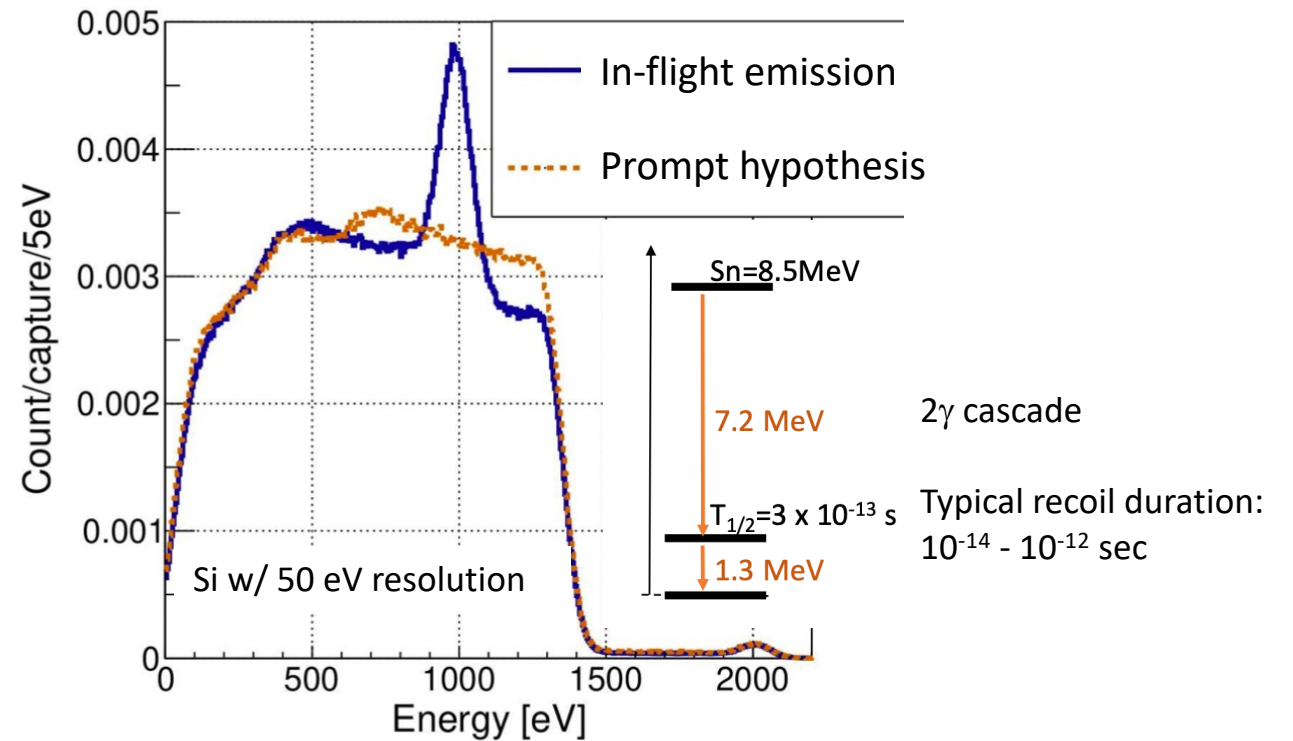

From G. Soum-Sidikov (M7s workshop 2023)

# CRAB: Towards a Precision Calibration Facility for the DM and CEvNS Community

2023

✓ Calibration of NUCLEUS detectors (CaWO<sub>4</sub>)

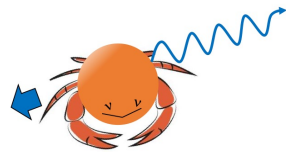

2024

- Study **linearity**
- Application to **other materials** beyond CaWO<sub>4</sub>
- Measurement of **quenching factor at sub-keV**

Proof of principle

Installation & first measurements @TU Wien

Upgrade:  $\gamma$ -tagging

Calibration facility Open for new collaborators

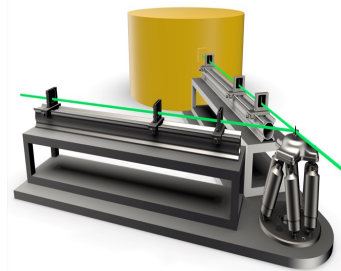

end of 2023

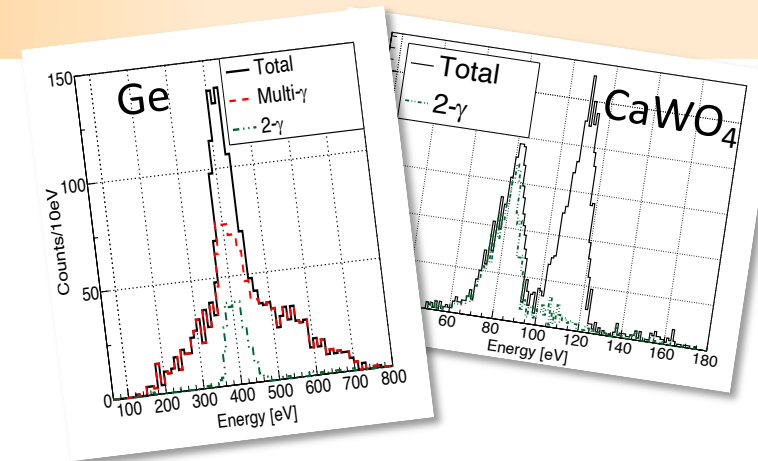

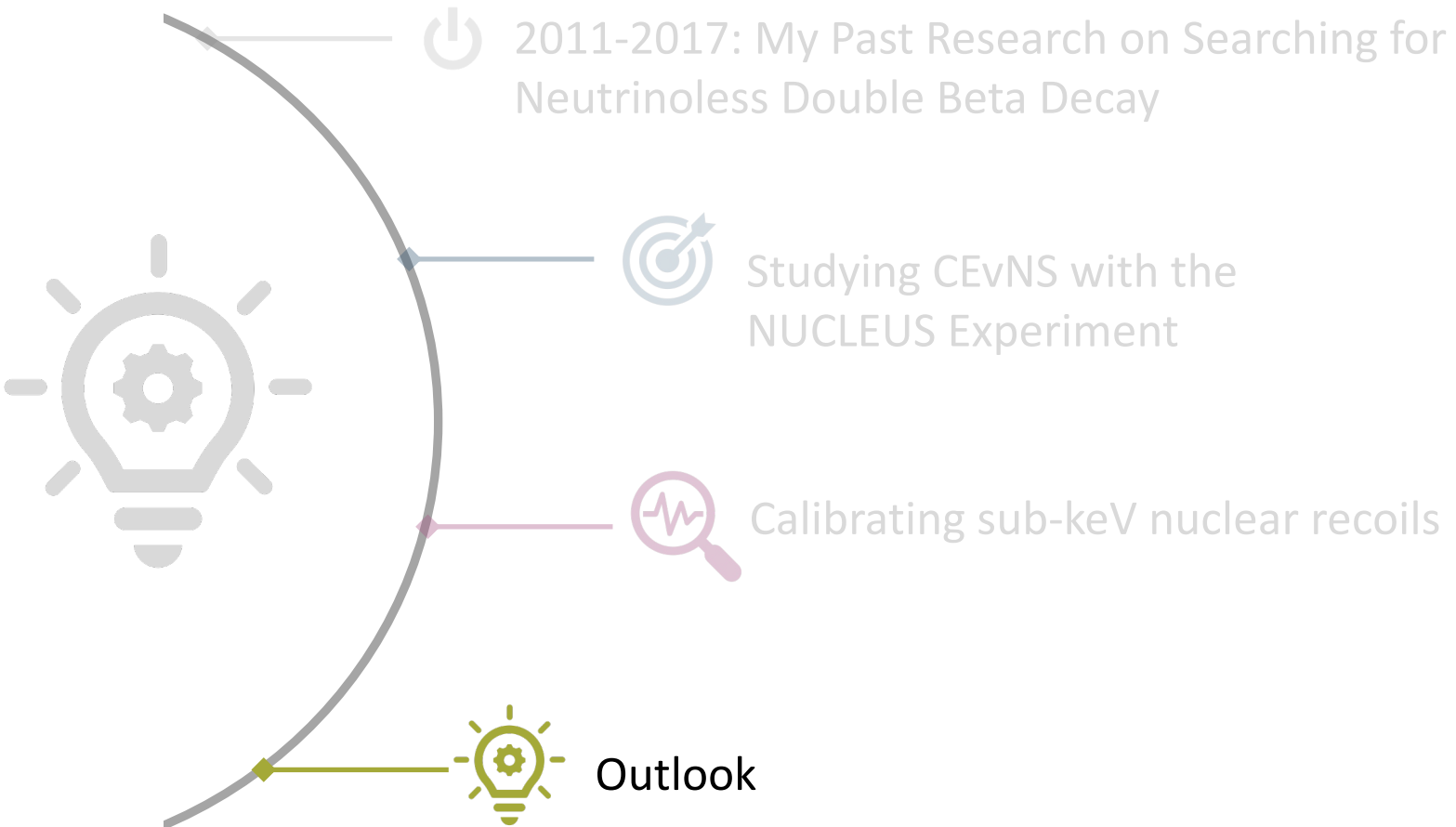

# Outline

---



# Outlook

- NUCLEUS combines very different detector systems
- Lots of exciting physics ahead with  & 
- **Milestone:** first observation of a 112 eV nuclear recoil peak from neutron capture



Main field of research: **neutrino physics** and **light dark matter**

Expertise in **particle detectors and analysis**

**Future:**

- find out what neutrinos are hiding so far – e.g. NSI, Majorana nature
- develop new (cryogenic) detectors for neutrino detection

# Thank you!



Contact: [Victoria.Wagner@tum.de](mailto:Victoria.Wagner@tum.de)

# COHERENT Experiment

modified from <https://coherent.ornl.gov/the-coherent-detector-suite/>

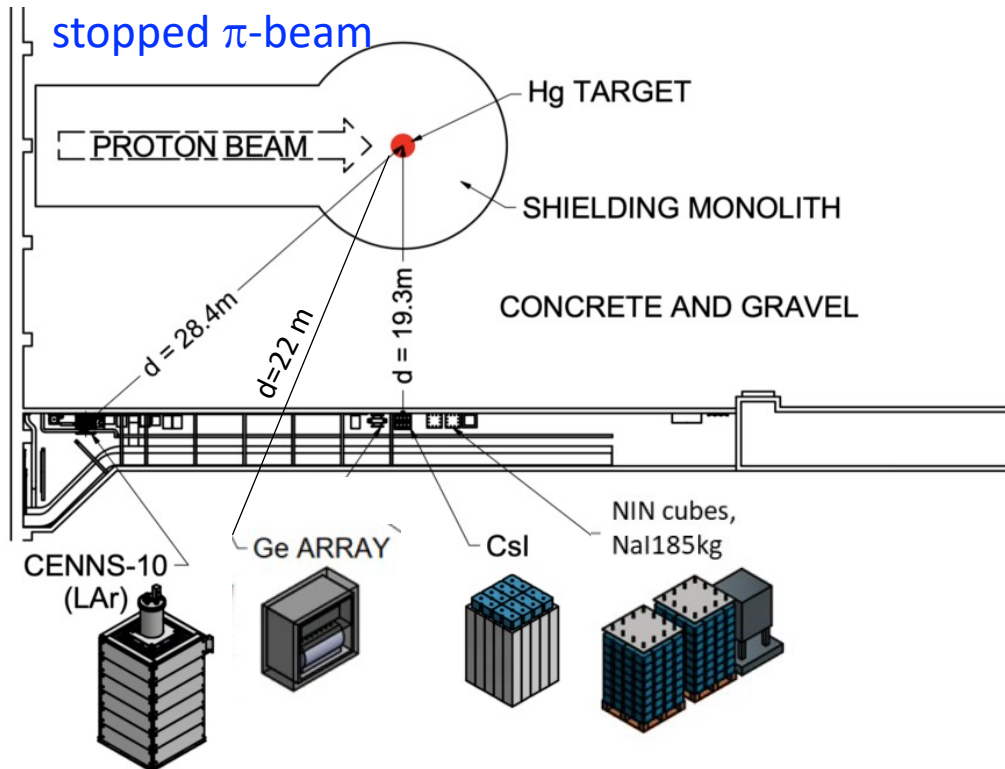

@Spallation Neutron Source (SNS) at Oakridge National Laboratory

Target	technology	Mass [kg]	Threshold [keV <sub>nr</sub> ]	Status
CsI[Na]	Scintillation	14.6	6.5	Decommissioned
<b>Results</b>	<b>First observation of CEvNS</b>			
Ar	Scintillation Single phase LAr	24/ 610	20	Running Upgrade 2024
<b>Results</b>				
Ge	Ionization HPGE PPC	18	< 5	Commissioning
NaI[Tl]	Scintillation	3388	13	Commissioning

# COHERENT Experiment

modified from <https://coherent.ornl.gov/the-coherent-detector-suite/>

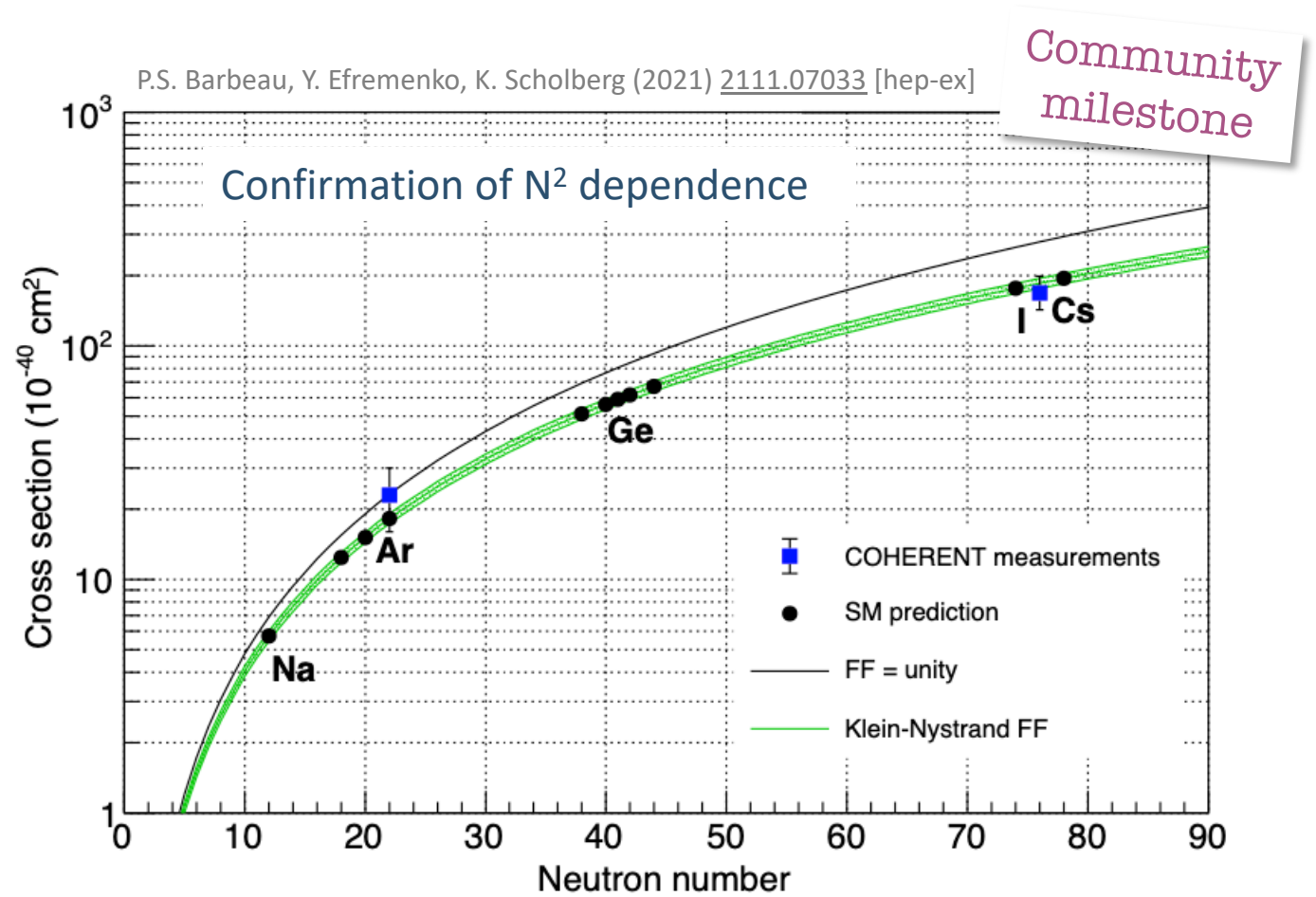
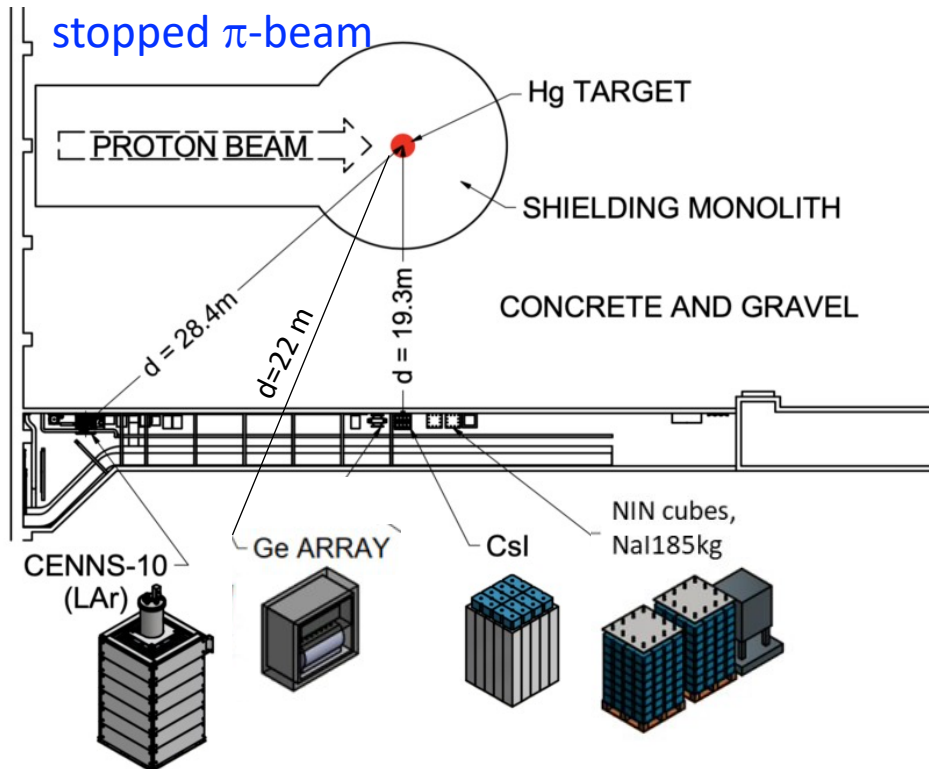

# Reactor Experiments

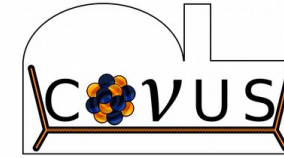

see also Teilchenkolloquium from May 30<sup>th</sup>, 2023

Experiment	Detector	Energy threshold	Status
CONUS	Ge ionization	O(1keV <sub>nr</sub> )	Finished Upgrade
TEXONO	Ge ionization	O(1keV <sub>nr</sub> )	Finished
Nu-GEN	Ge ionization	O(1keV <sub>nr</sub> )	Running
Dresden	Ge ionization	O(1keV <sub>nr</sub> )	Running
NEON	NaI(Tl) ionization	O(1keV <sub>nr</sub> )	Running
RED-100	Liquid Xe TPC	O(1keV <sub>nr</sub> )	Construction
CONNIE	CCD (Si)	~300eV <sub>nr</sub>	Running
MINER	Cryogenic (Ge, Si)	O(100eV <sub>nr</sub> )	Commissioning
RICOCHET	Cryogenic (Ge, Zn)	55eV <sub>nr</sub>	Construction
NUCLEUS	Cryogenic (CaWO <sub>4</sub> )	20eV <sub>nr</sub>	Construction

### Reactor Sites



Brokdorf, Germany

Power	3.9GW <sub>th</sub>
Cores	1
Baseline	17m
$\nu$ -flux	$2.2 \times 10^{13} \text{ cm}^{-2}\text{s}^{-1}$

- new limit on CEvNS signal from reactor neutrinos:  
**factor ~2 (90% C.L.) above SM prediction**  
**assuming Lindhard theory with k=0.162**

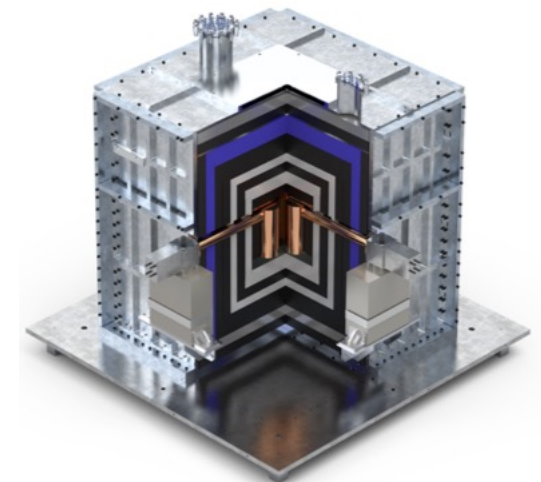
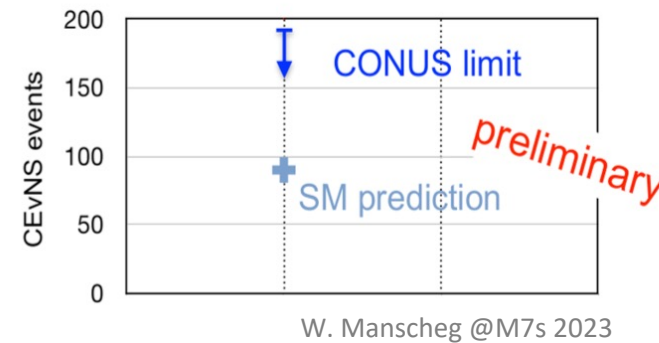

# Gram-scale Cryogenic Detectors

- ✓  $\text{Al}_2\text{O}_3$  prototype with threshold  
 $E_{\text{th}} = (19.7 \pm 0.8) \text{ eV}_{\text{nr}}$
- ✓ Operation above ground with low  
rate  $\mathcal{O}(0.1 \text{ Hz})$

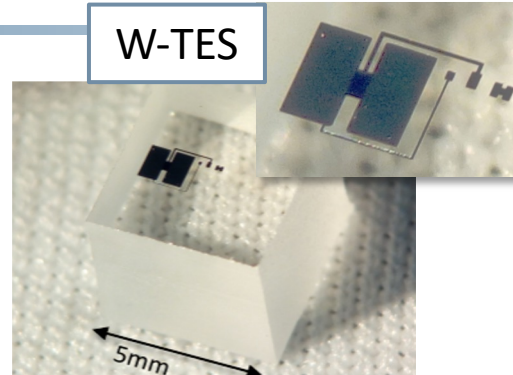

*Phys. Rev. D 96, 022009 (2017)*

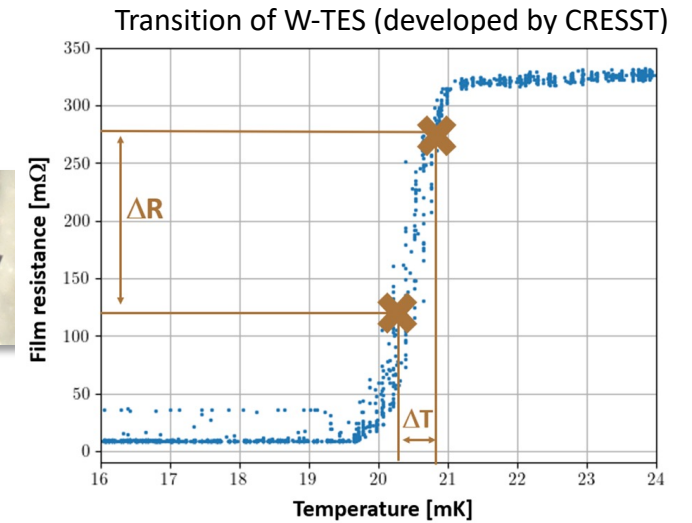

First tests yield promising performance:

- ✓ 18  $\text{CaWO}_4$  crystals equipped with W-TES have been tested:  $T_c < 21 \text{ mK}$
  - ✓ Baseline resolution below 10 eV
  - ✓ Rise time  $< 0.5 \text{ ms}$
  - ✓ Decay time 15 ms
- } Crucial for operation above-ground  
& in coincidence with veto

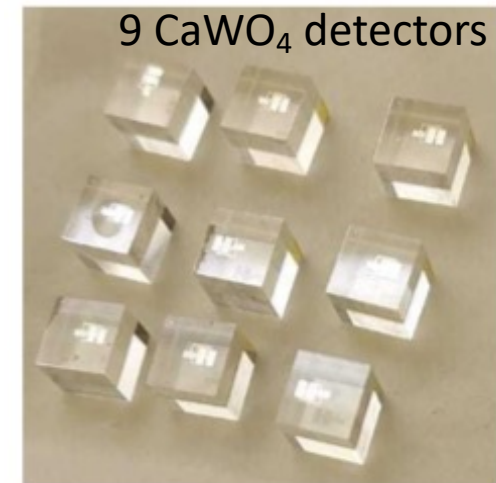

# The Inner Veto

**Inner veto: TES-instrumented holder**  
to reject surface backgrounds and  
holder-related events

- ✓ Mechanical and thermal test with mock-up
- Next steps: Replacement of 2nd wafer with *beaker* for a  $4\pi$ -coverage

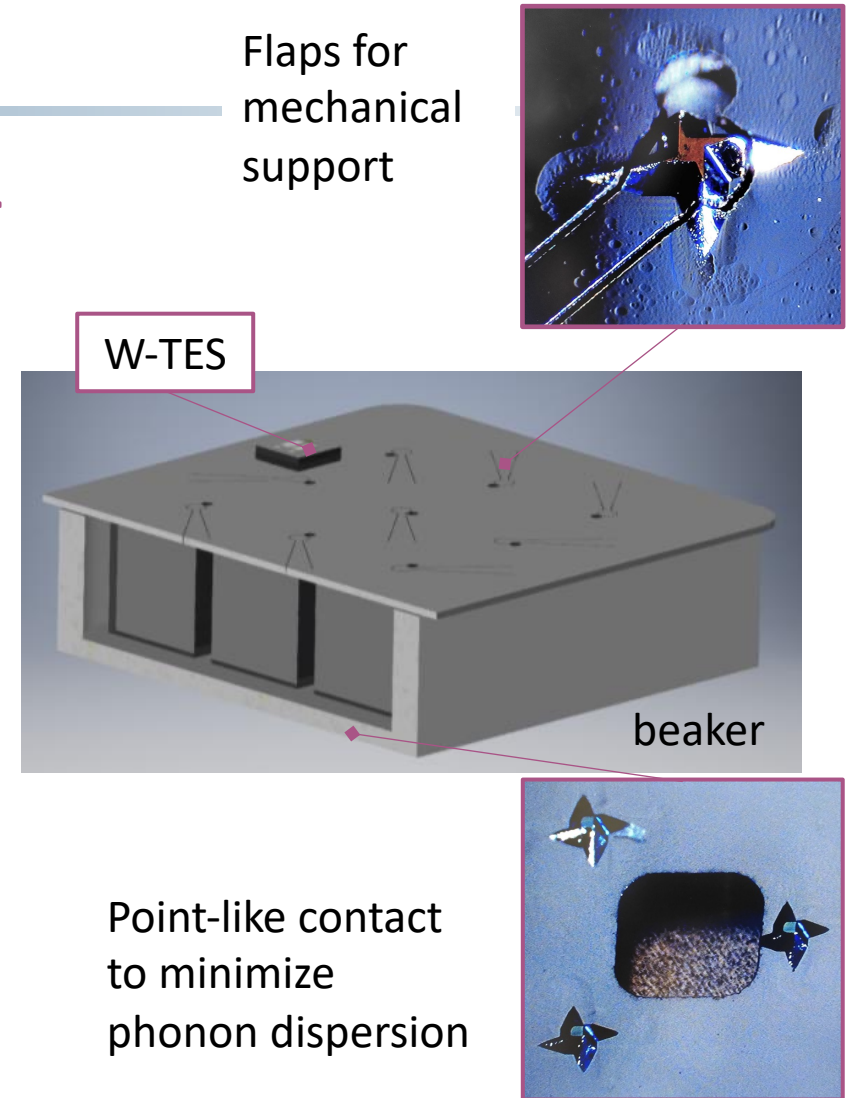
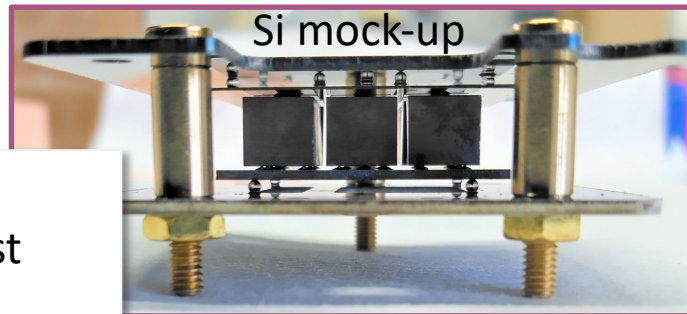

# The Outer Veto

Mock-up (steel)

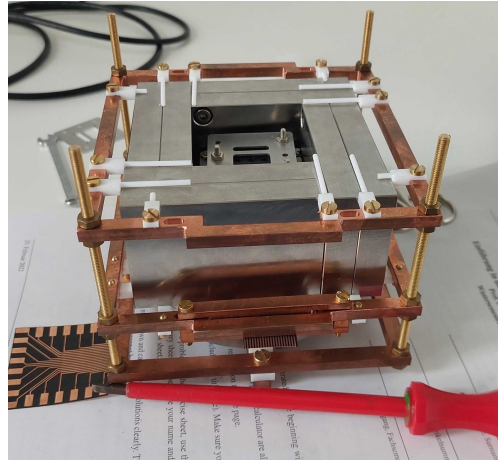
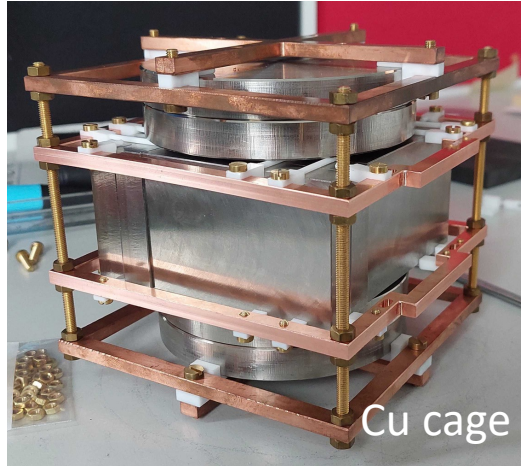
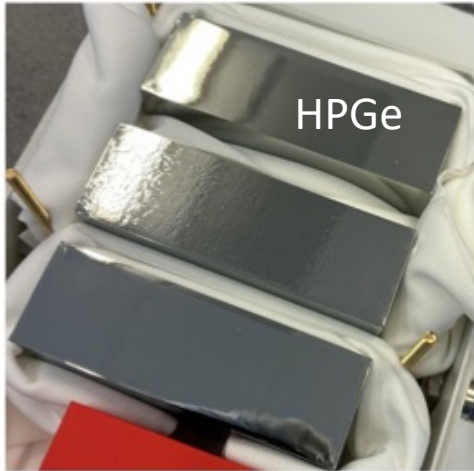

Germanium outer veto  
for active  $\gamma/n$  background  
rejection

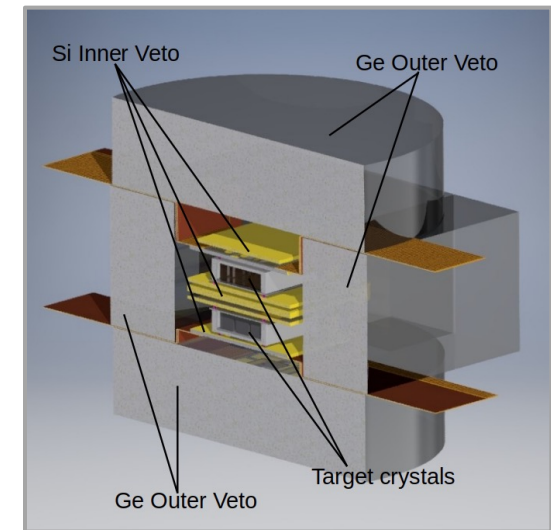

- Active ionization detector
- 4 kg of 2.5 cm thickness in 6 HPGe crystals with thresholds  $< 10$  keV
- $4\pi$  coverage
- ✓ Cryogenic HPGe detectors produced

# Quenching of Nuclear Recoils

- CEvNS results depend on the quenching of nuclear recoils

$$E_{ER} = QF(E_{NR}) \cdot E_{NR} = \frac{k \cdot g(\epsilon)}{1 + k \cdot g(\epsilon)} E_{NR}$$

$$\epsilon = 11.5 Z^{-7/3} E_{NR}$$

$$g(\epsilon) = 3\epsilon^{0.15} + 0.7\epsilon^{0.6} + \epsilon$$

**Quenching**

- ! Dependence of CEvNS rate
- ! High uncertainty on  $N_{CEvNS}$

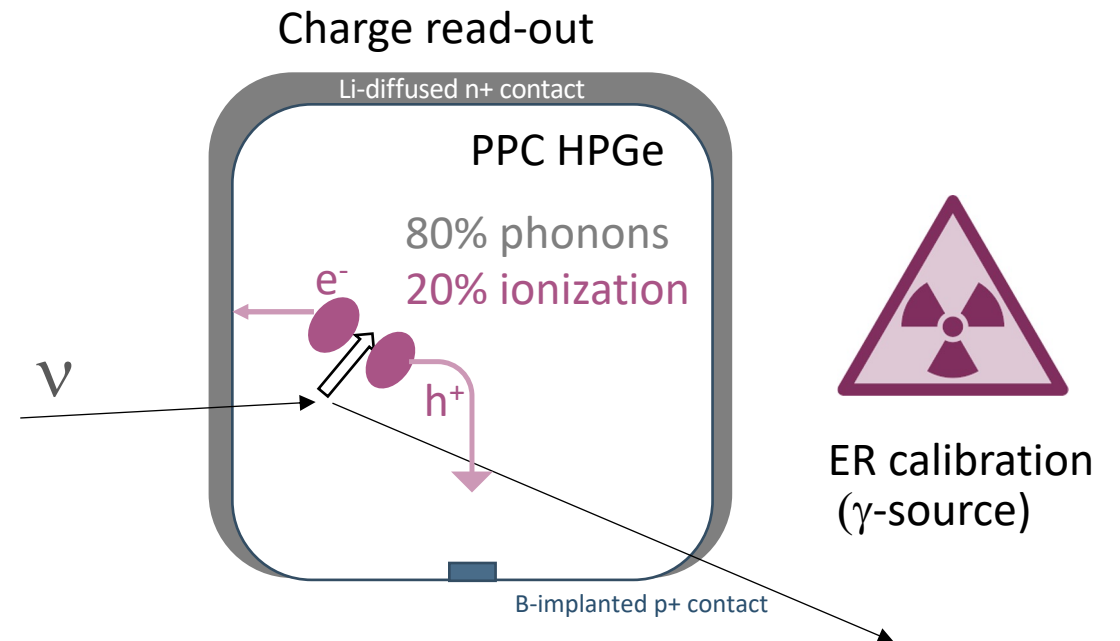
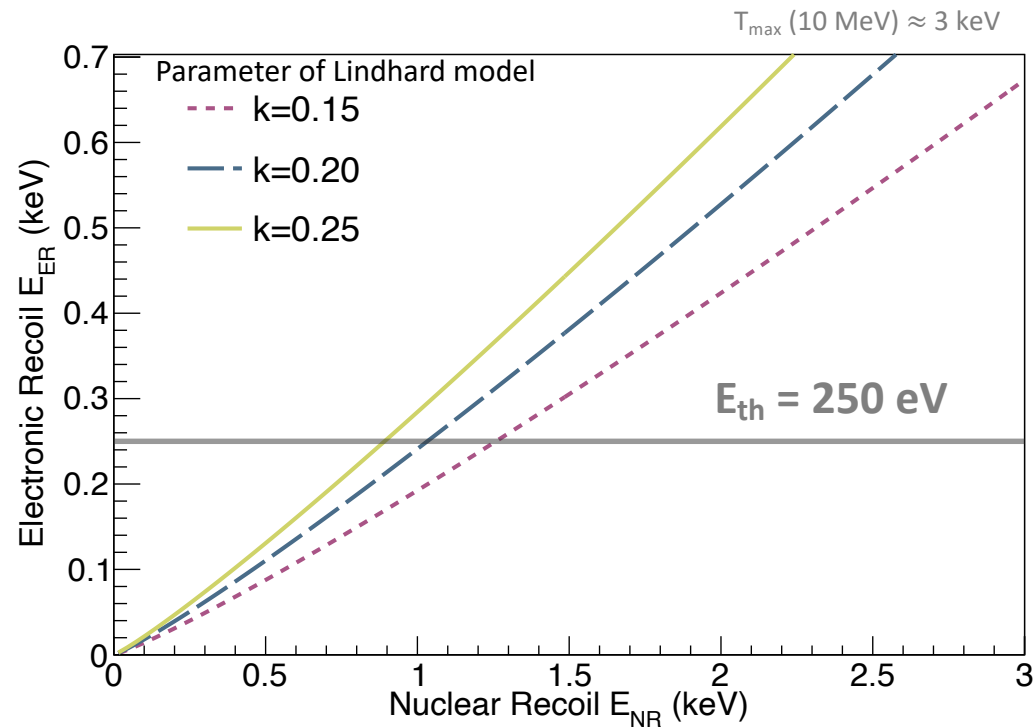

# Precision Calibration with CRAB

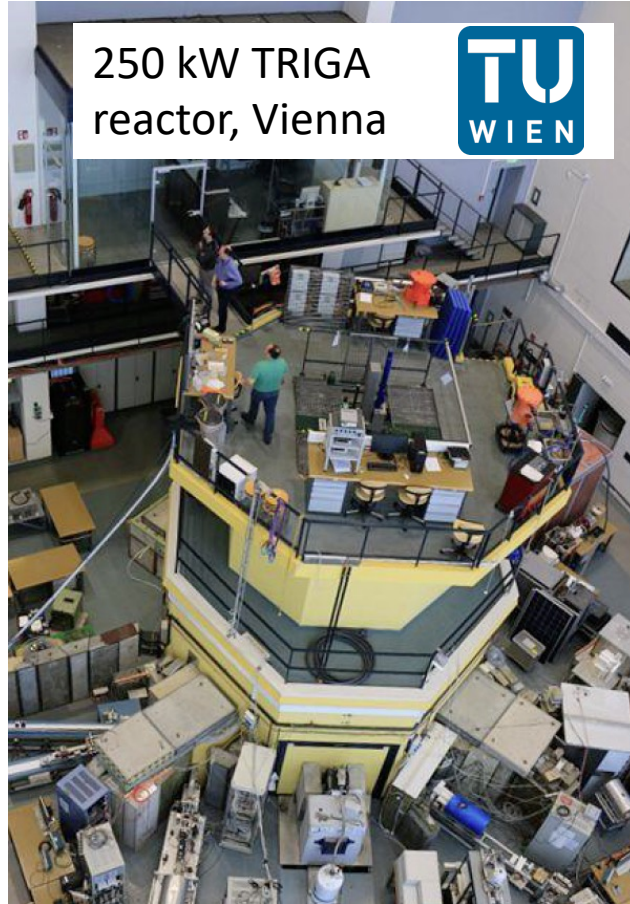

- ✦ Clean thermal neutron beam → research reactor
  - ✦ Event rate in cryo detectors limited to O(few Hz)
  - ✓ **Low power TRIGA reactor in Vienna** provides optimal conditions: low neutron rate 1-100 n/cm<sup>2</sup>/s
- no reduction of intensity needed & acceptable background of fast neutrons and  $\gamma$ -rays
- ⚙ On-going
    - Beam line construction
    - Neutron simulation

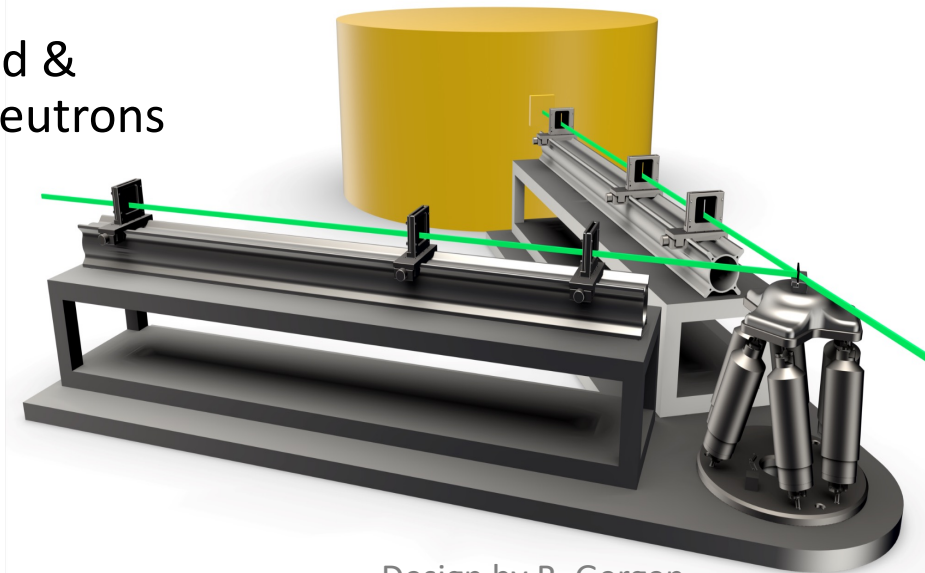

# CEvNS Physics

Precision measurement of the weak neutral current:  $\sigma \sim [Z(g_V^p + 2\varepsilon_{\alpha\alpha}^{uV} + \varepsilon_{\alpha\alpha}^{dV}) + N(g_V^n + \varepsilon_{\alpha\alpha}^{uV} + 2\varepsilon_{\alpha\alpha}^{dV})]^2$   
 $g_V^p = +\frac{1}{2} - 2\sin^2\theta_W$

Weinberg angle at low E-transfer

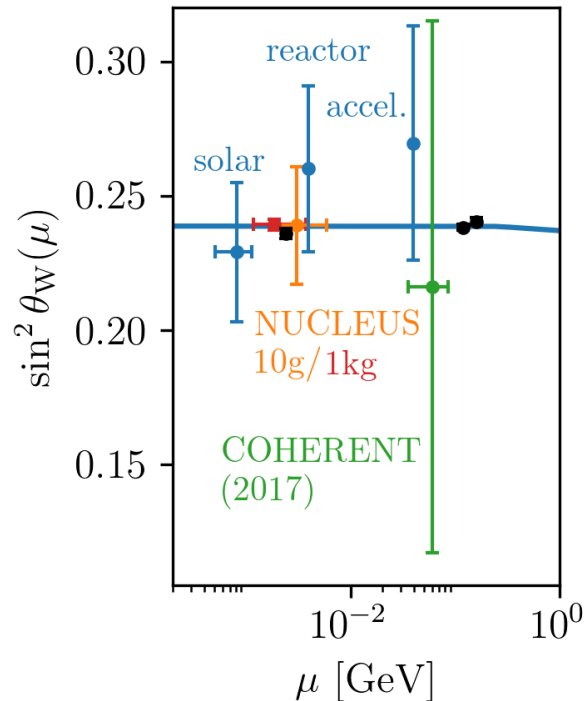

Neutrino non-standard interactions

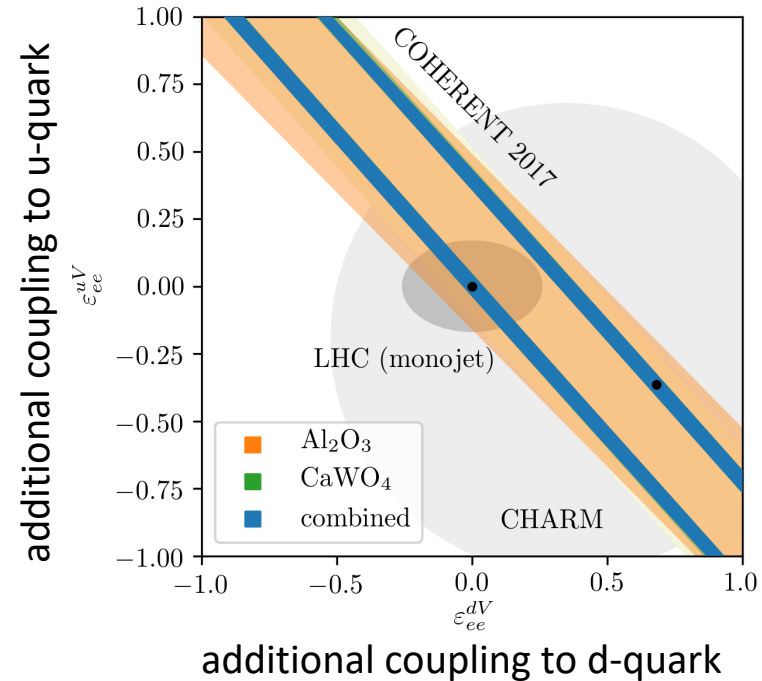

From J. Rothe, Dissertation, TUM (2021)

# NUCLEUS Sensitivity

- NUCLEUS-10g will reach a precision of **~10% on CEvNS**
- Reach out to new energy regime (**10-100 eV**)

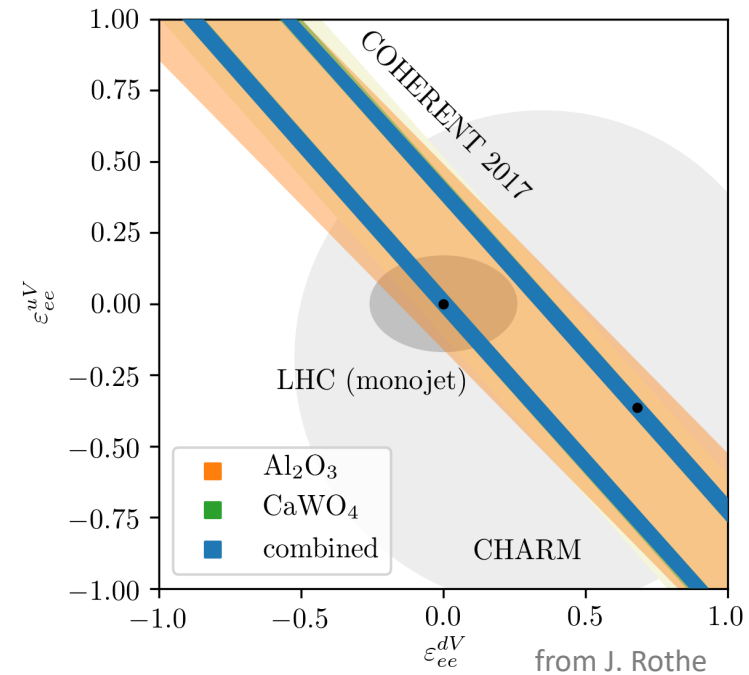
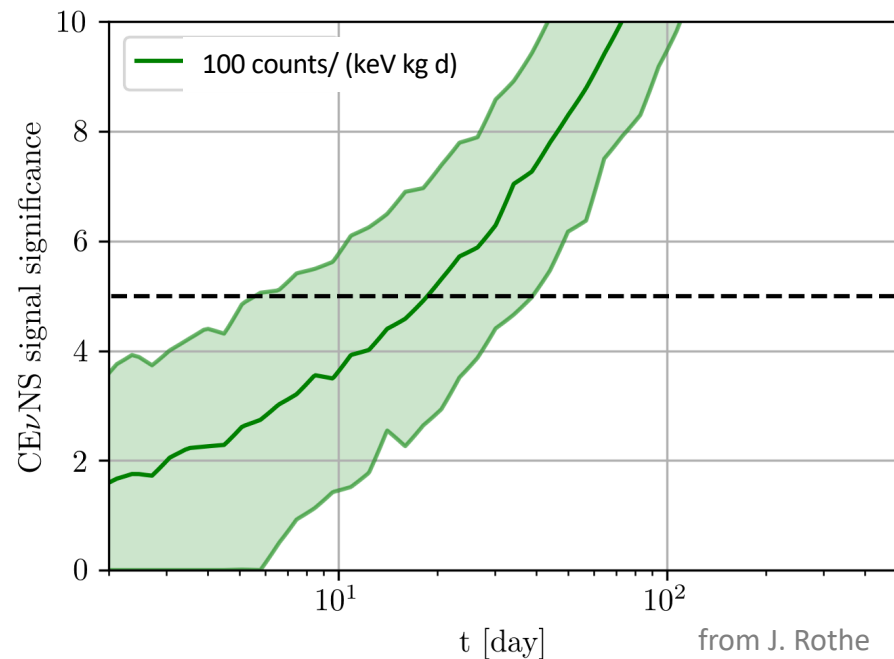
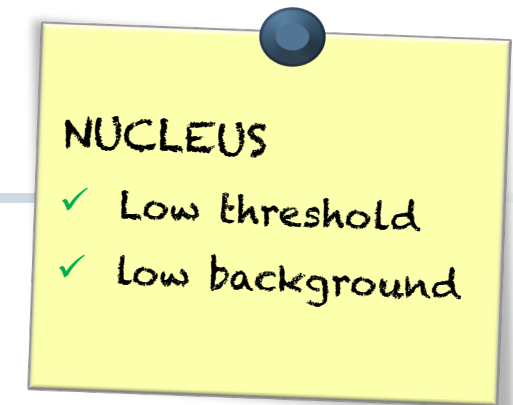

# Discovery Potential for NUCLEUS-10g

- First measurement of  $\nu$ 's **below 1.8 MeV**
- In case of flat BI = 100 counts/(keV kg d) **observation after 2 weeks**
- In case of signal like background: observation after 1 year -> unique to multi-target approach

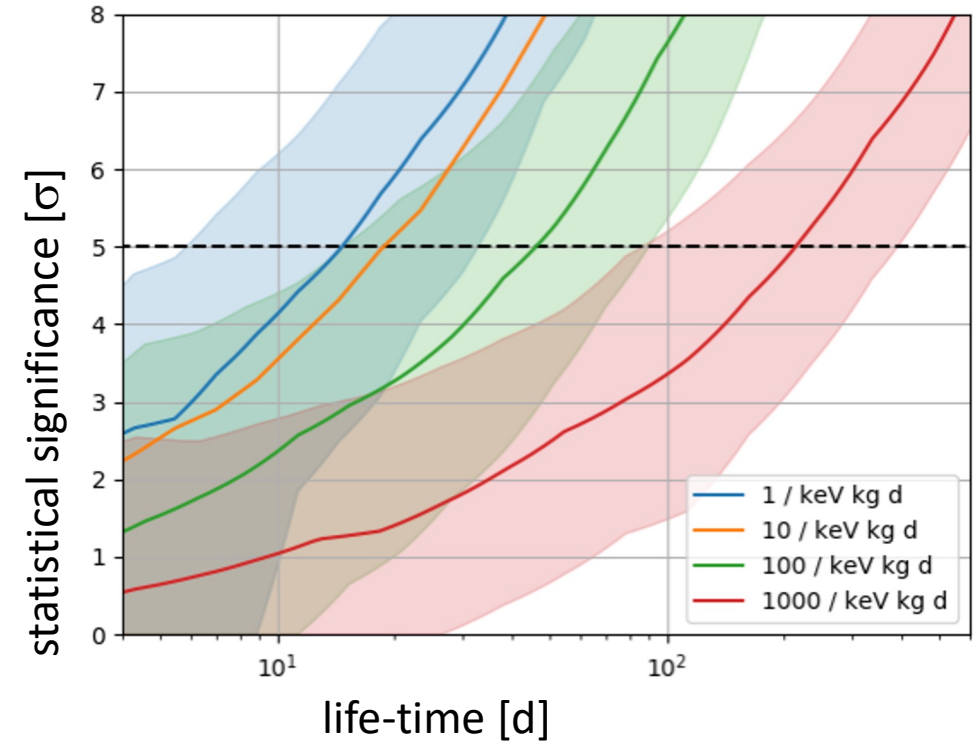



## Signal Precision

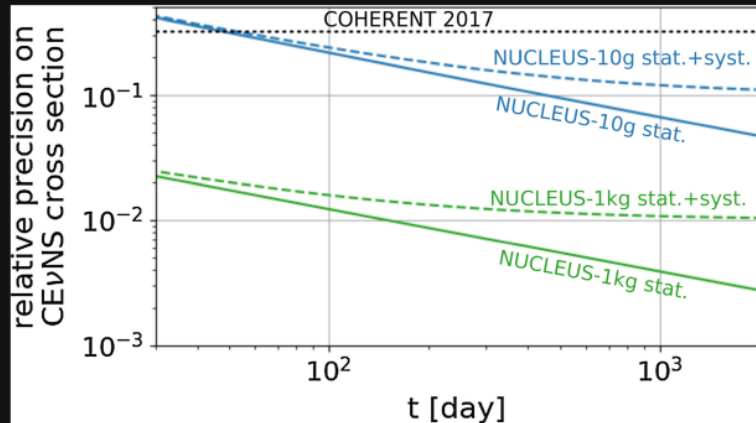

Relative precision of the CEvNS cross-section measurement as a function of live time for the experimental stages NUCLEUS-10g (composed of  $\text{CaWO}_4$  and  $\text{Al}_2\text{O}_3$  detectors), and NUCLEUS-1kg (modeled as a Ge detector array). The solid lines show statistical uncertainties (one standard deviation) only, for the dashed lines a systematic uncertainty of 10% (1%) is added in the case of NUCLEUS-10g (NUCLEUS-1kg). The dotted horizontal line indicates the 32% precision achieved by COHERENT (adding in quadrature the 16% experimental uncertainty and the 28% uncertainty of the rate prediction).  
From G. Angloher, F. Ardellier-Desages and A. Bento et al.  
Exploring CEvNS with NUCLEUS at the Chooz nuclear power plant.



- **NUCLEUS-10g**

- First physics results on CEvNS of reactor neutrinos in reach
- 10% precision on CEvNS cross section
- eventually limited by statistics

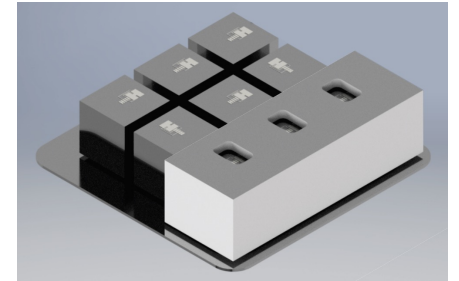

- **NUCLEUS-1kg**

- Upgrade towards 1 kg mass
- Goal 1% precision measurement of CEvNS

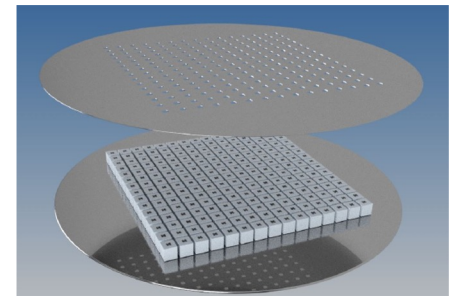

# Neutrino Magnetic Moment (NMM)

$$\frac{d\sigma}{dE_R} = \frac{G_F^2}{4\pi} Q_W^2 F^2(q^2) \cdot m_N \left( 1 - \frac{E_R}{E_R^{\max}} \right)$$

- Non-zero magnetic dipole moment of neutrino adds term
- NMM could provide information on nature of neutrinos
- Anomalously high NMM would indicate new physics

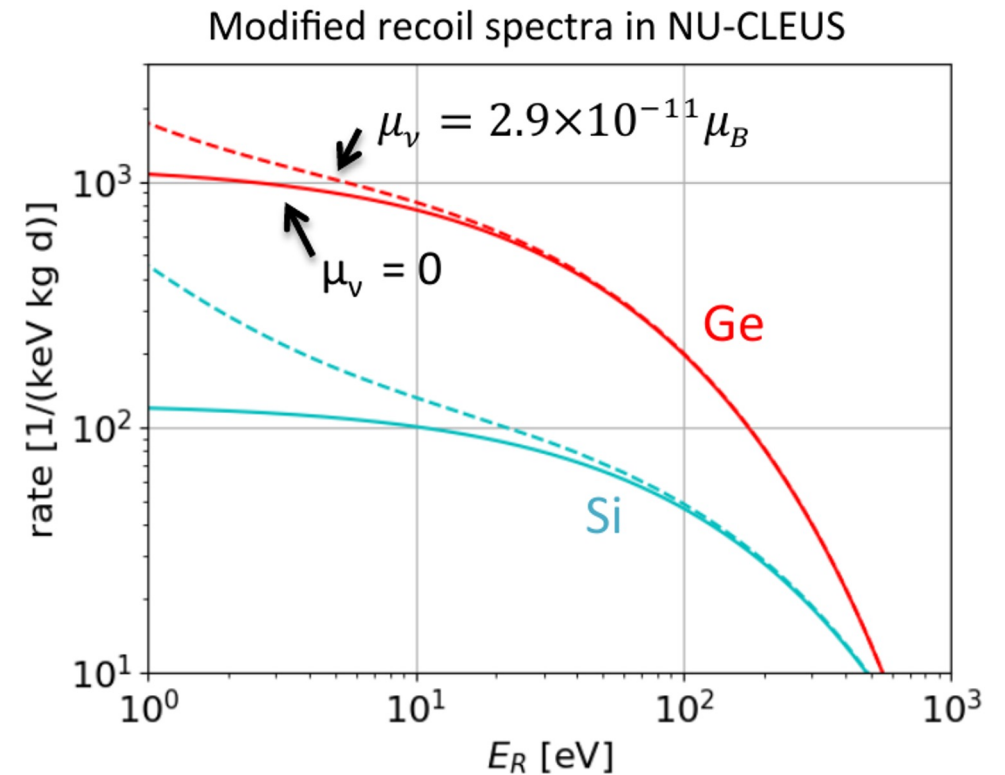

# Latest COHERENT Results on Csl

D. Akimov, et al. (COHERENT Collaboration), Phys.Rev.Lett. 129 (2022) 8, 081801

$$\sigma \sim [Z(g_V^p + 2\varepsilon_{\alpha\alpha}^{uV} + \varepsilon_{\alpha\alpha}^{dV}) + N(g_V^n + \varepsilon_{\alpha\alpha}^{uV} + 2\varepsilon_{\alpha\alpha}^{dV})]^2$$

$$g_V^p = +\frac{1}{2} - 2\sin^2\theta_W$$

- Measurement of the weak mixing angle  $\sin^2\theta_W = 0.220 \pm 0.028$  at  $Q^2 \approx (50 \text{ MeV})^2$
- Improvements on CEvNS constraints on **neutrino-quark NSI** scenarios
- Measurement of flavored CEvNS cross-section by neutrino timing

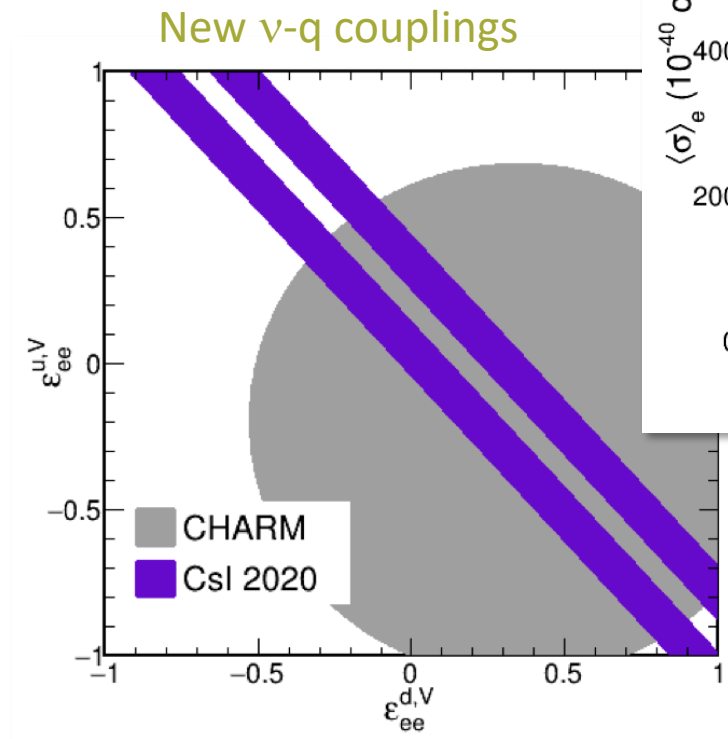

“Flavored” CEvNS cross-section

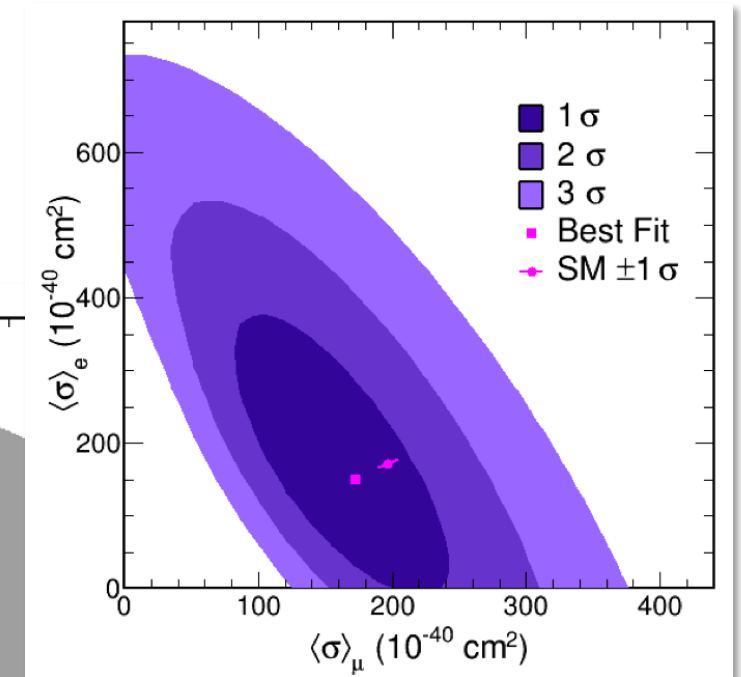

# Studying Solar Neutrinos with DM Detectors

XENON1T *Phys.Rev.Lett.* 126 (2021) 091301

- No excess of  $^8\text{B}$  CEvNS events found
- Limits on new couplings
- XENONnT has large potential to measure CEvNS of  $^8\text{B}$  neutrinos

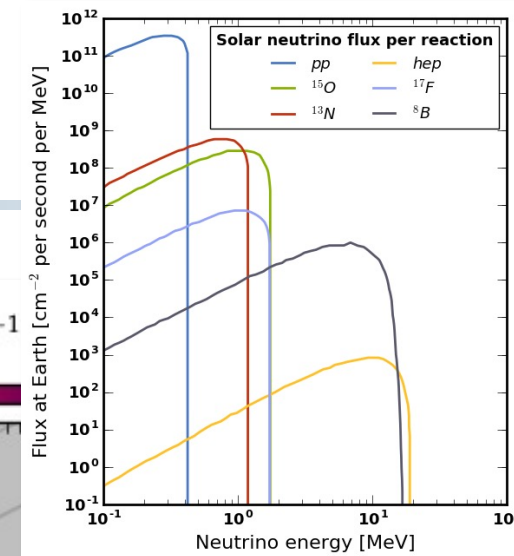
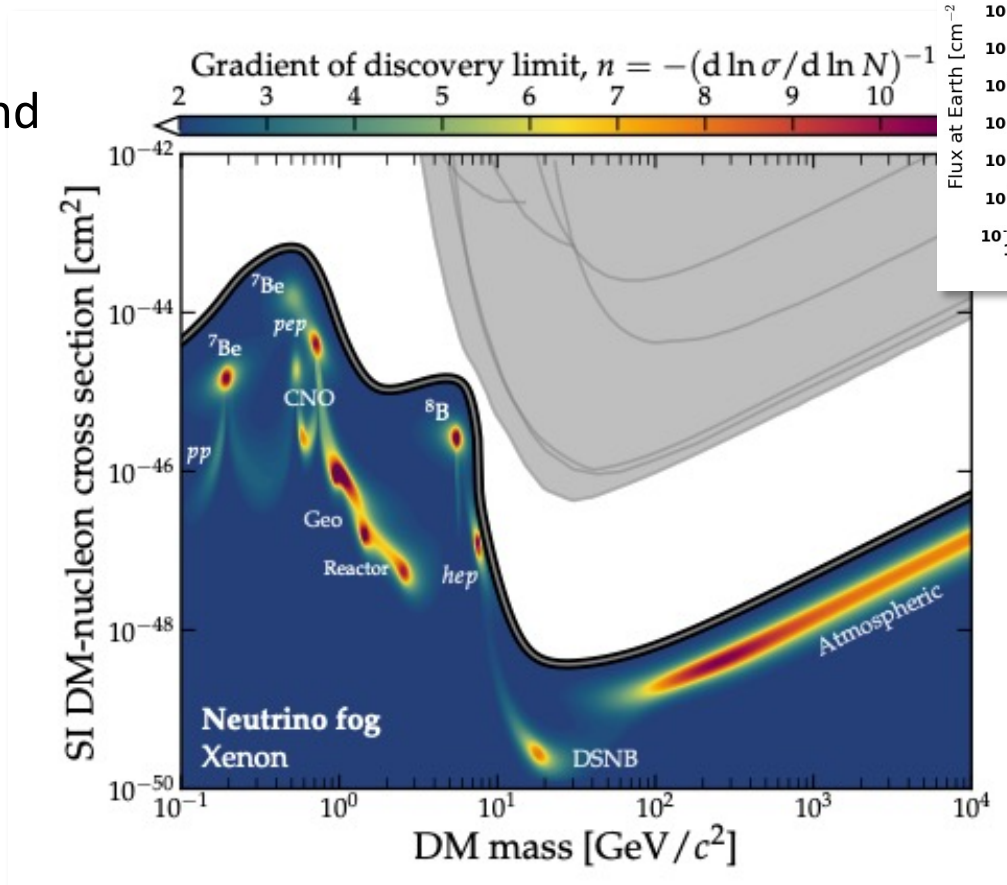
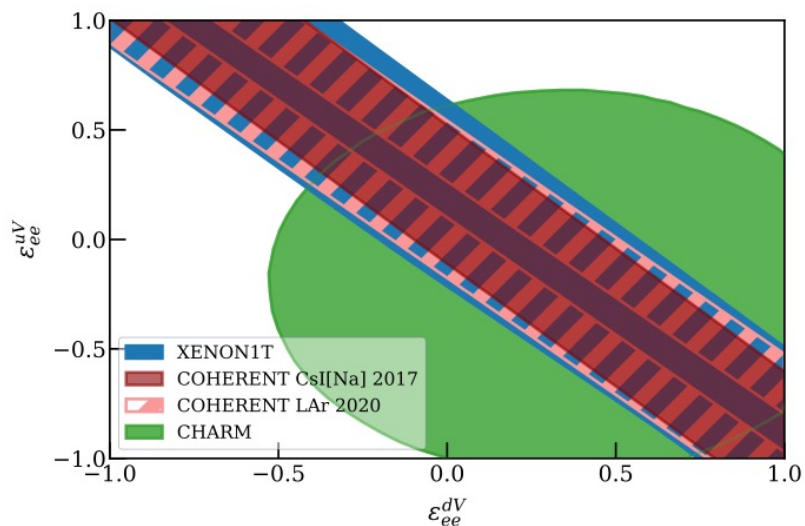

$$\sigma \sim (M^{-1/n})$$

$n < 2$ : bck free

$n = 2$ : Possion

$n > 2$ : saturation by bck

Plot from [arXiv:2203.07361](https://arxiv.org/abs/2203.07361) [hep-ph],

Original work: C. A. J. O'Hare, *Phys. Rev. Lett.* 127, 251802 (2021)