

A single volume neutron scatter camera A work in progress

Jason Nattress

ORNL is managed by UT-Battelle LLC for the US Department of Energy

Project Team



- Project title: “**Single-Volume Scatter Camera Development**”
- Participants: Six institutions
 - **SNL/CA (lead)**: [E. Brubaker](#), [M. Sweany](#), [J. Brown](#), J. Steele, B. Cabrera-Palmer, et al.
 - **ORNL**: [P. Hausladen](#), K. Ziock, M. Febbraro, M. Folsom, J. Nattress, et al.
 - **ANL**: J. Elam, [A. Mane](#), M. Gebhard, A. Letorneau
 - **U Hawaii**: [K. Nishimura](#), J. Learned, A. Druetzler, A. Galindo Tellez, R. Dorrill, K. Keefe, N. Kaneshige, et al.
 - **UC Berkeley/LBNL**: B. Goldblum, T. Laplace, [J. Manfredi](#), et al.
 - **NCSU**: J. Mattingly, K. Weinfurther, [M. Mishra](#), A. Moustafa

What we are (were) trying to do?

- **Specific goal:** make a neutron scatter camera both more efficient and more compact
- **General goal:** enable interaction-resolving neutron detectors (distinguishing first interaction, multiple interactions also interesting for transmission imaging, coded aperture imaging, multiplicity counting)
- **Monolithic approach:** resolve multiple neutron interactions within a monolithic scintillator volume using the **arrival times** and **locations** of scintillation photons at the surface of the scintillator
- **First prototype:** uses MAPMTs and COTS digitizers

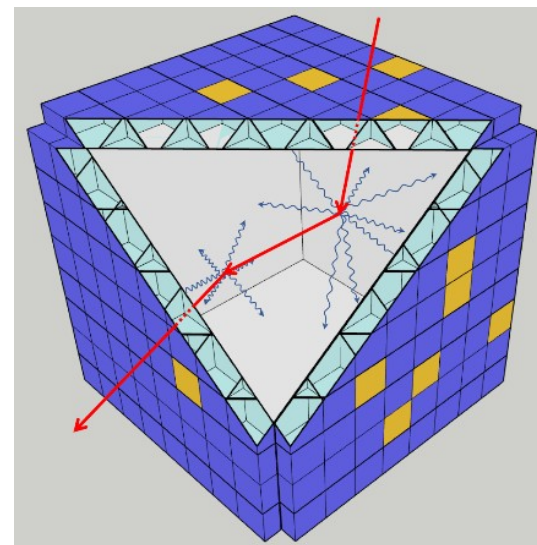
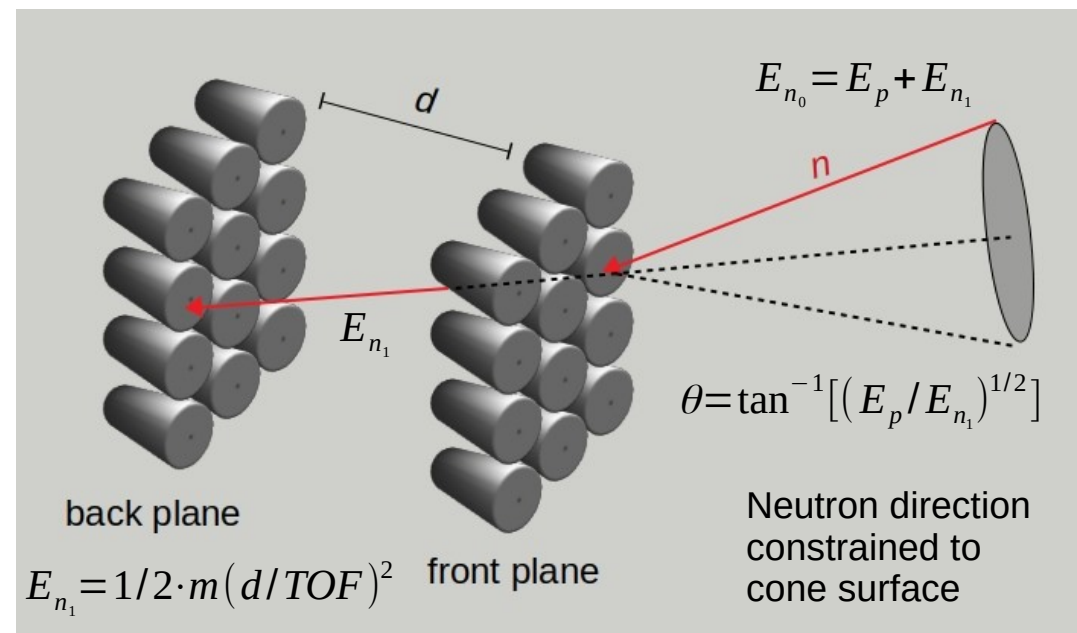

If successful:

- Spectroscopic capability
- Good per-event angular resolution
- High efficiency
- Compact form factor

Prototype Approach

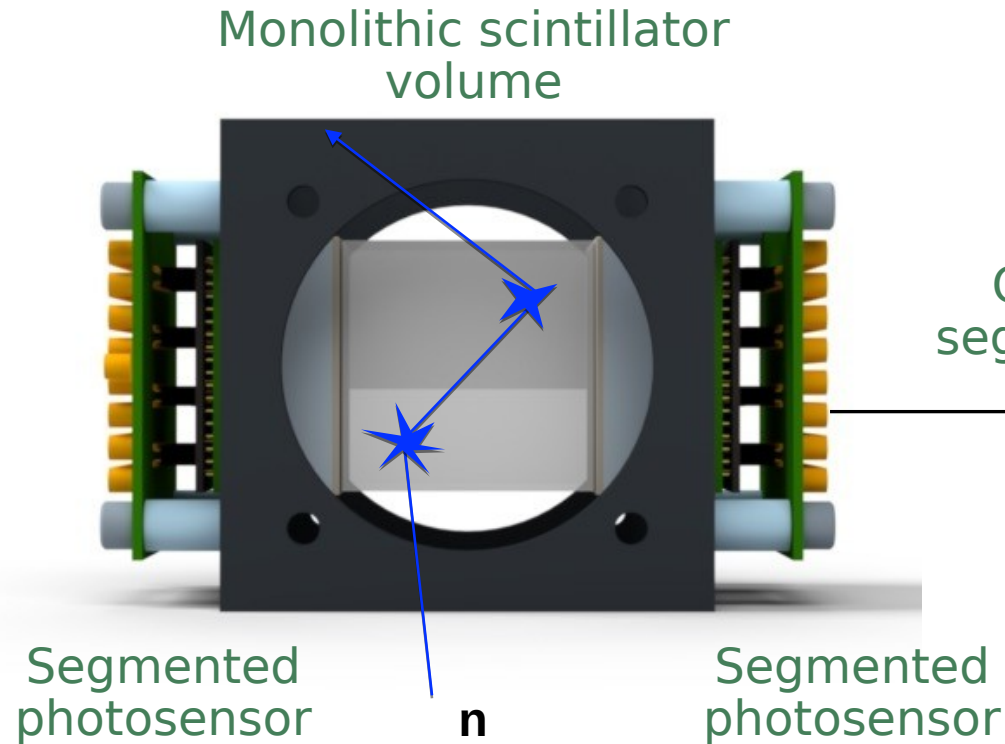

1

Photosensors:

- Position sensitive (multi anode)
- Fast timing
- Count single photoelectrons

2

Data acquisition:

- Use fast digitizers to record photosensor waveforms

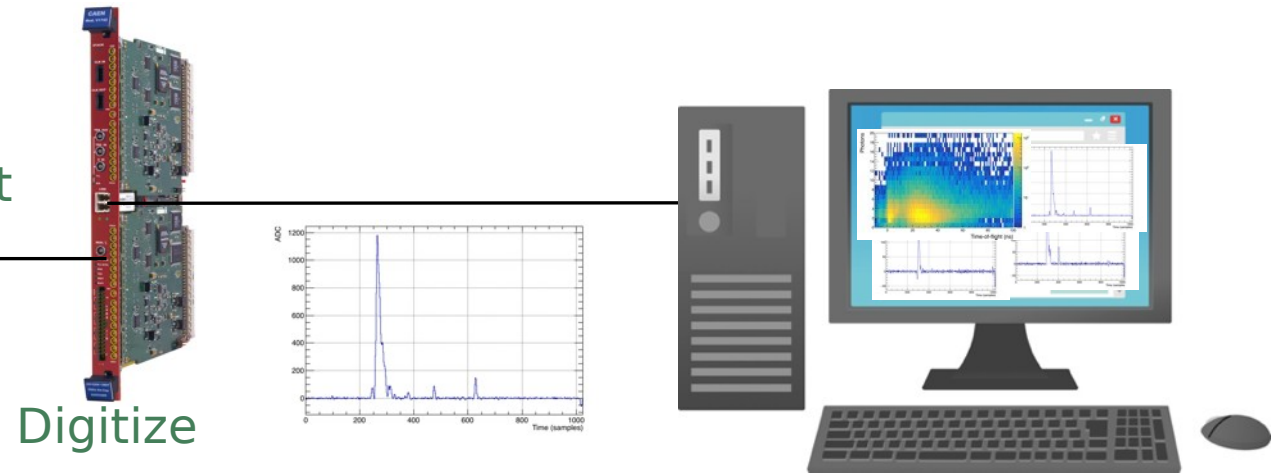

3

Analysis

- Extract PE number, locations, times
- Output to event reconstruction

4

Event reconstruction

- Maximize likelihood to identify interaction positions, times
- Image double scatters

The monolithic approach

Hamamatsu
H12700 64-
anode PMTs

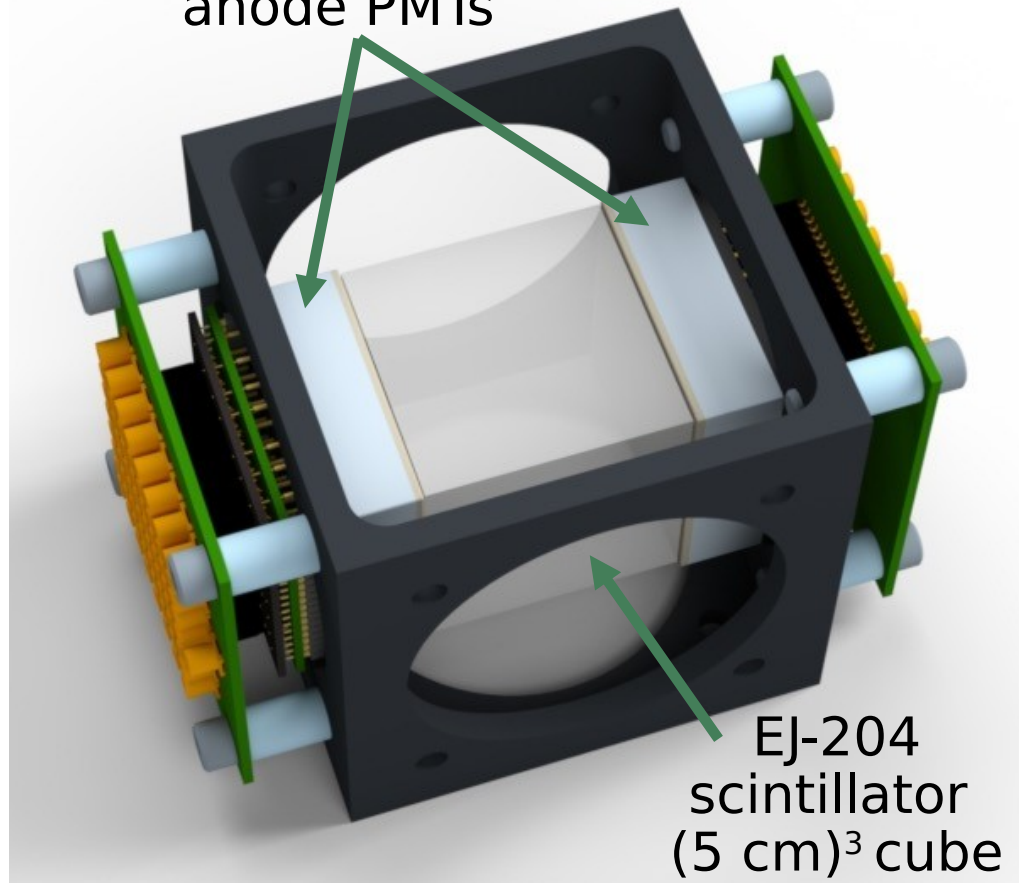

EJ-204
scintillator
(5 cm)³ cube

Scintillator
and PMTs

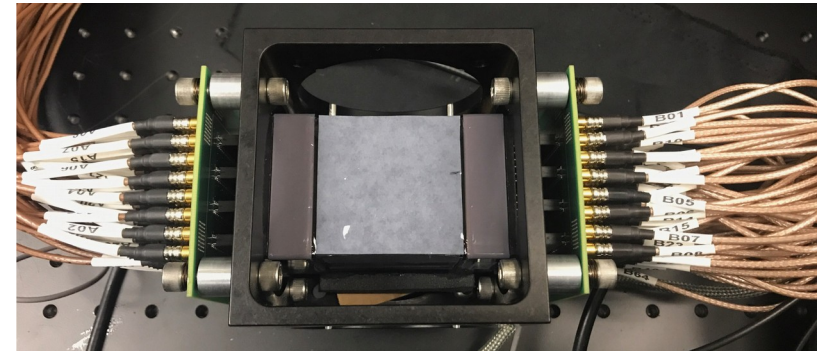

4 CAEN V1742
32-channel,
5 GSs⁻¹, 12 bit
digitizers
(DRS-4 chip)



Dell 7920 16-
core
workstation +
CAEN A3818
optical interface

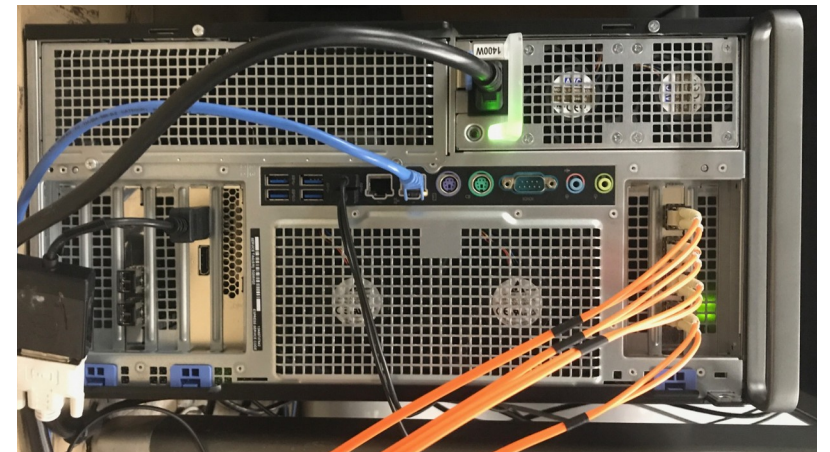

Challenge 1: crosstalk

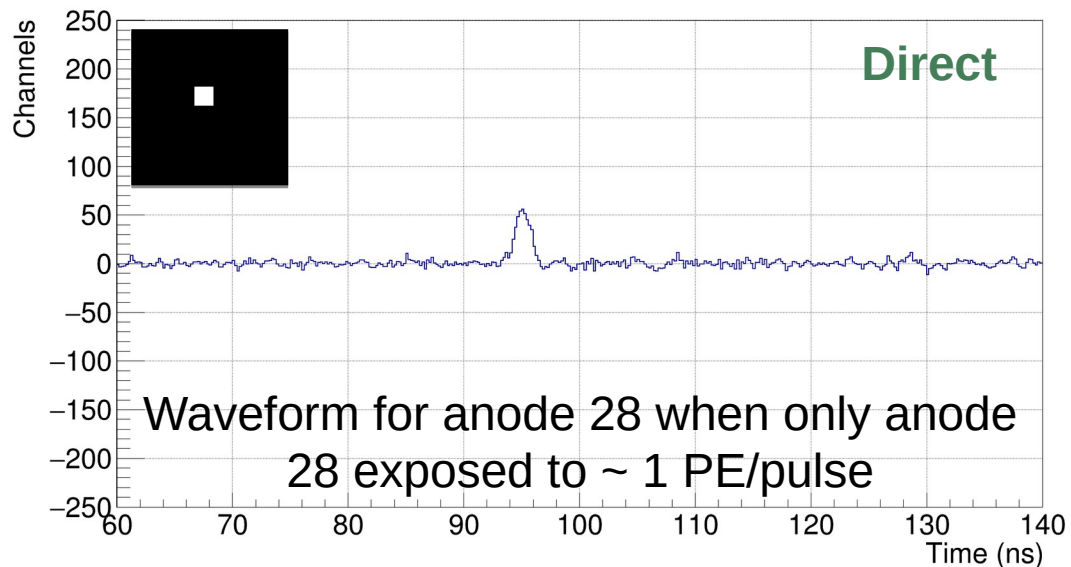

+

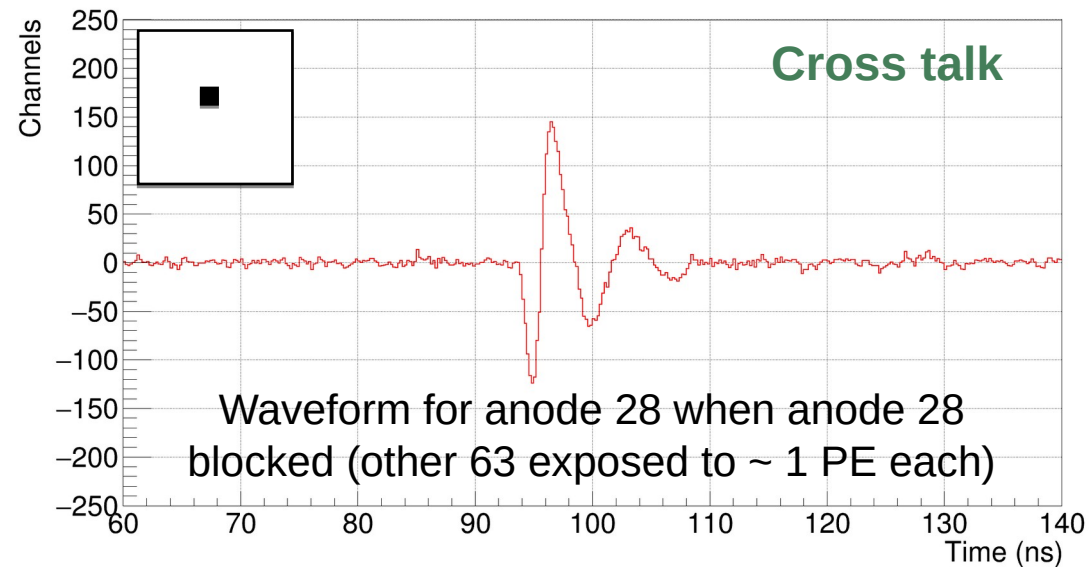

=

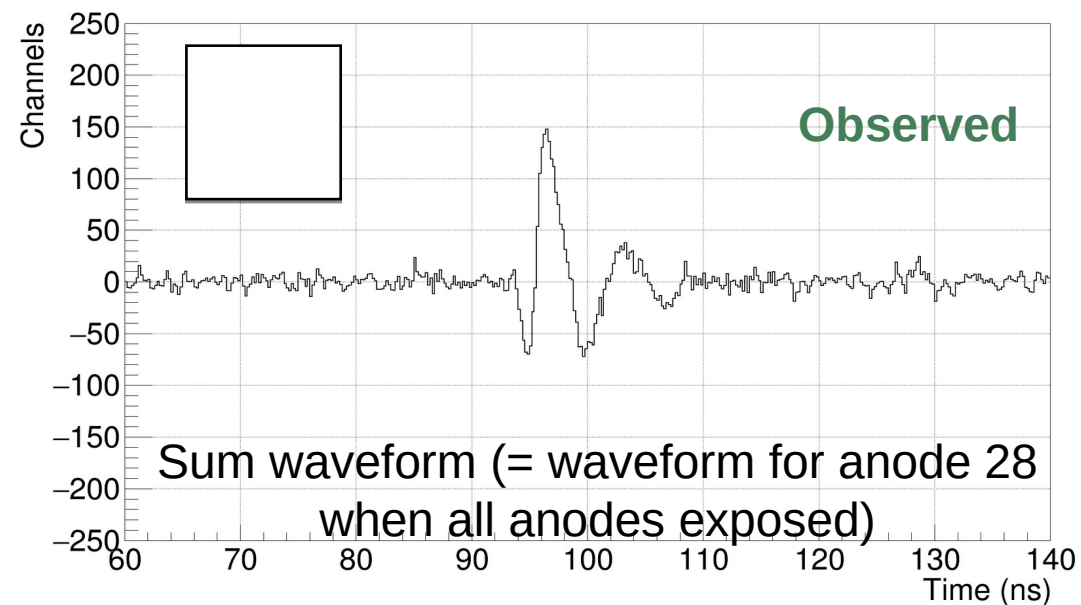

Uniformly exposed PMT to ~ 1pe/anode using laser and diffuser. Each anode gets ~1/64th of total.

Signal in one anode induces a few percent cross talk in every other anode due to coupling of anode pixel through common dynode

Challenge 2: calibrations

Experimental setup to measure single PE quantities

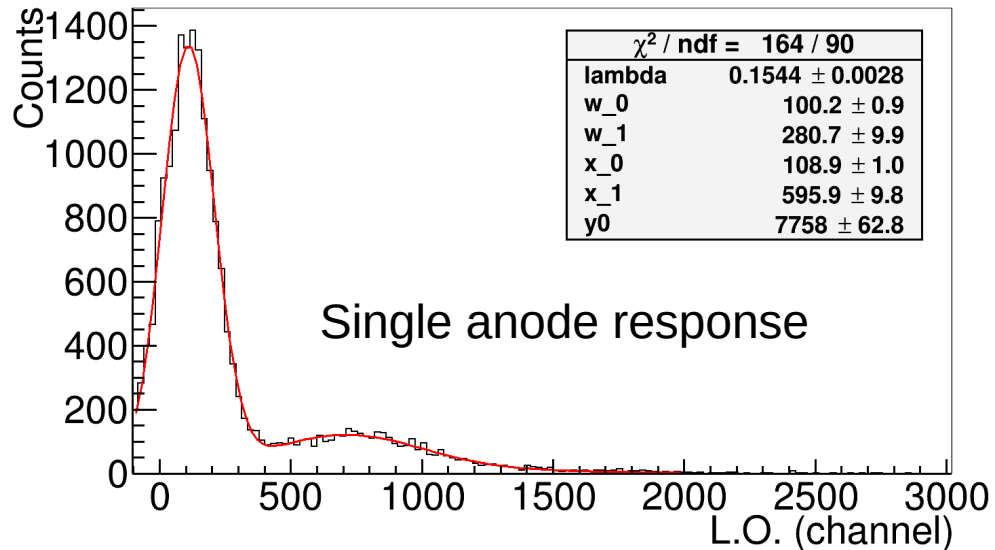
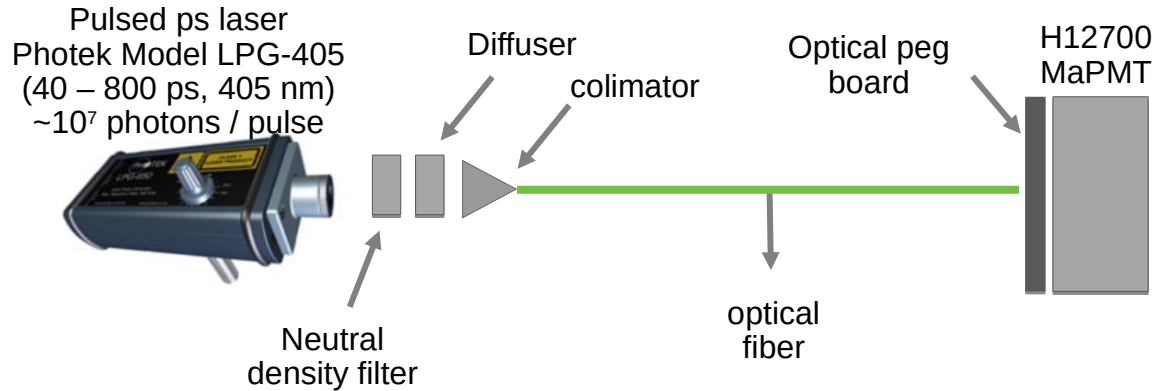

$$S(x) = N \sum_{n=0}^5 \frac{\lambda^n e^{-\lambda}}{n!} \cdot \frac{\Delta x}{\sqrt{2\pi \cdot (w_0^2 + nw_1^2)}}$$

n = number of pe
 λ = mean from Poisson distribution
 w_0 = width of zero
 w_1 = width of 1 pe
 x_0 = position of 0 pe
 x_1 = position of 1 pe
 Δx = bin width

$$\exp\left(\frac{-\frac{1}{2}(x - (x_0 + nx_1))^2}{(w_0^2 + nw_1^2)}}\right)$$

$$\sigma^2 = N_A \left(1 + \left(\frac{\sigma_{pe}}{\mu_{pe}}\right)^2\right) + \alpha N_T$$

N_A = number of pe in an anode
 N_T = total number of pe in a single PMT
 $\sigma_{pe} = w_1$
 $\mu_{pe} = x_1$
 α = x-talk contribution

Challenge 3: uncertainty

We need accurate errors on anodes with “no” PEs

We isolated pixels where there is little to no direct signal (mostly crosstalk) and see how it scales with the number of PE

0	1	2	3	4	5	6	7
8	9	10	11	12	13	14	15
16	17	18	19	20	21	22	23
24	25	26	27	28	29	30	31
32	33	34	35	36	37	38	39
40	41	42	43	44	45	46	47
48	49	50	51	52	53	54	55
56	57	58	59	60	61	62	63

Event selection (units in mm):

- $z > -5$ & $z < 5$
- $x > 16$ & $x < 21$
- $(pmtb_r/pmtb) > .4$
- $(pmtb_r/pmtb) < .6$
- $y > 0$ && $y < 4$

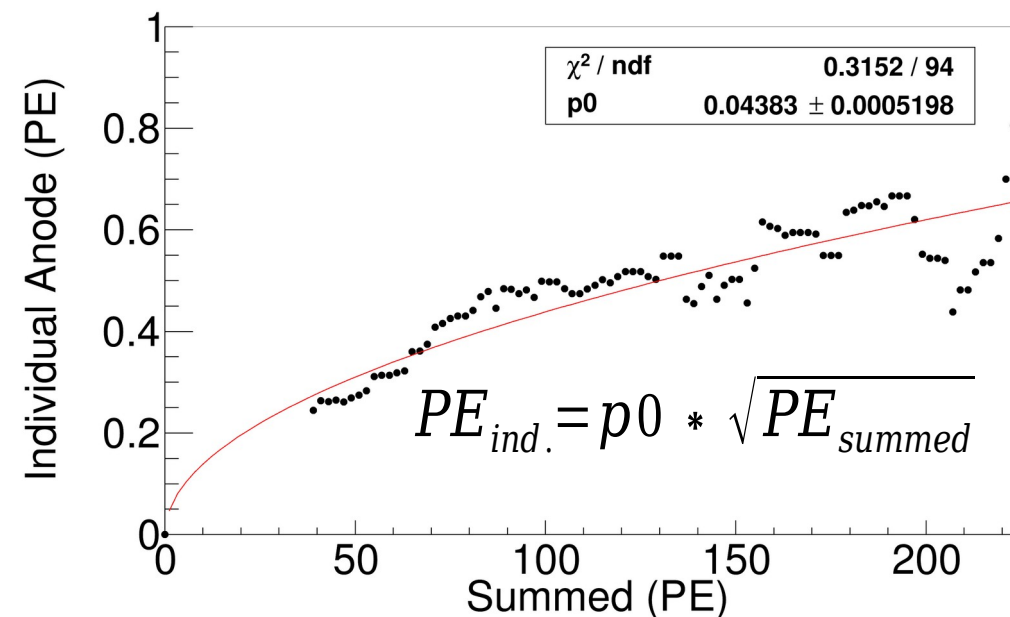
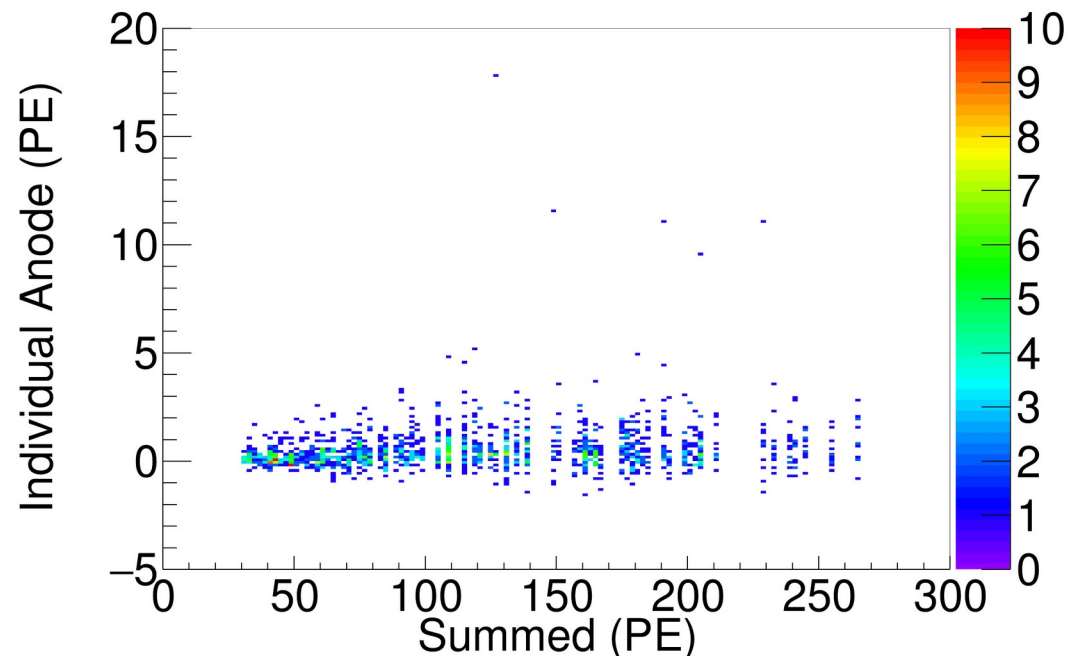
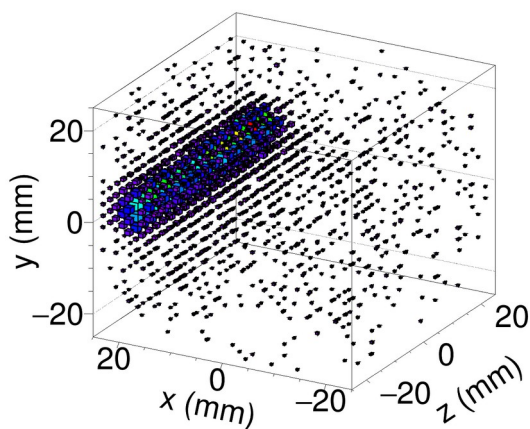

Challenge 4: reflections

Approach: Geant4 to simulate a few positions with high accuracy to reproduce data

Use simulation results to build an analytical response model including reflections

Calculate probability of a photon emitted from a voxel, i , being detected at an anode, j , for n number of reflections

$$P_{i,j,n} = QE_j e^{-r/\lambda} R_{pmt}^{n_x} R_{side}^{n_y} R_{side}^{n_z} d\Omega(\vec{r})$$

Voxel size: 1 mm² (voxels)

Fit hit pattern with 4 (8 for double) free parameters (x, y, z, and number of photons), interpolating the response between precalculated mesh points

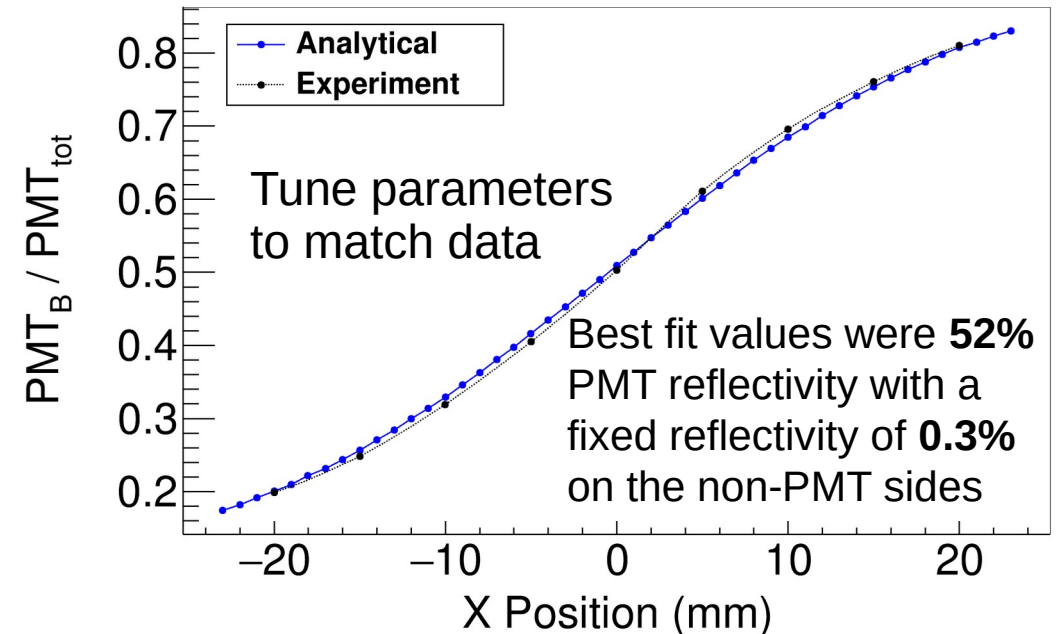
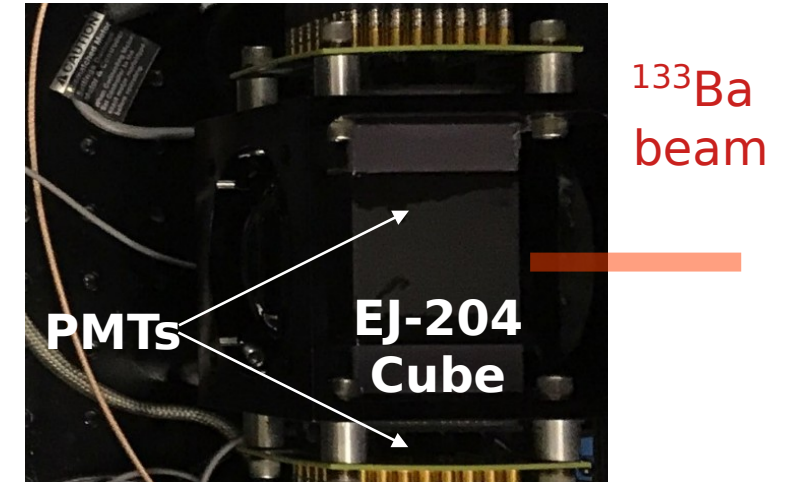

Challenge 5: after-pulsing

Long electron orbits give pulses that look much like a second interaction for about 10% of pulses

Study to evaluate the time dependence of PMT anode signals originating from scintillation light from scattering events in the 52 mm × 52 mm × 52 mm cube of EJ-204

Scintillation pulses were induced by 662 keV gamma rays from a ^{137}Cs source and coincident waveforms were recorded by a Rhode and Schwarz RTO 1024 2 GHz 10GSs⁻¹ digitizing oscilloscope.

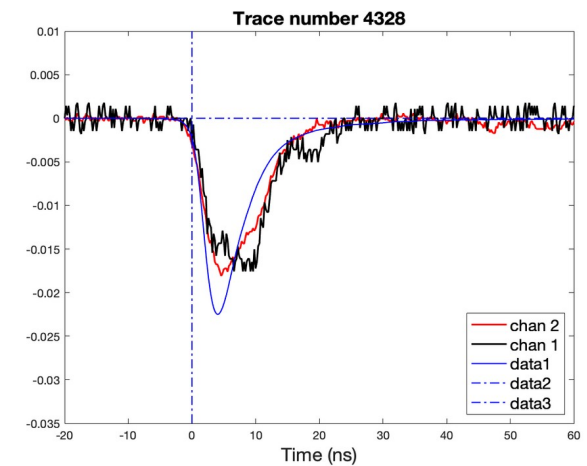
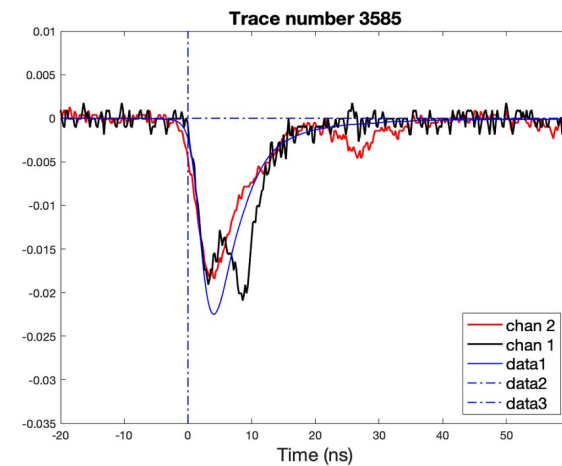
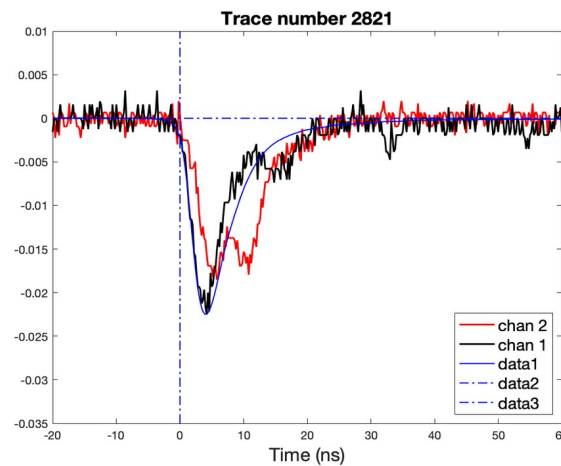
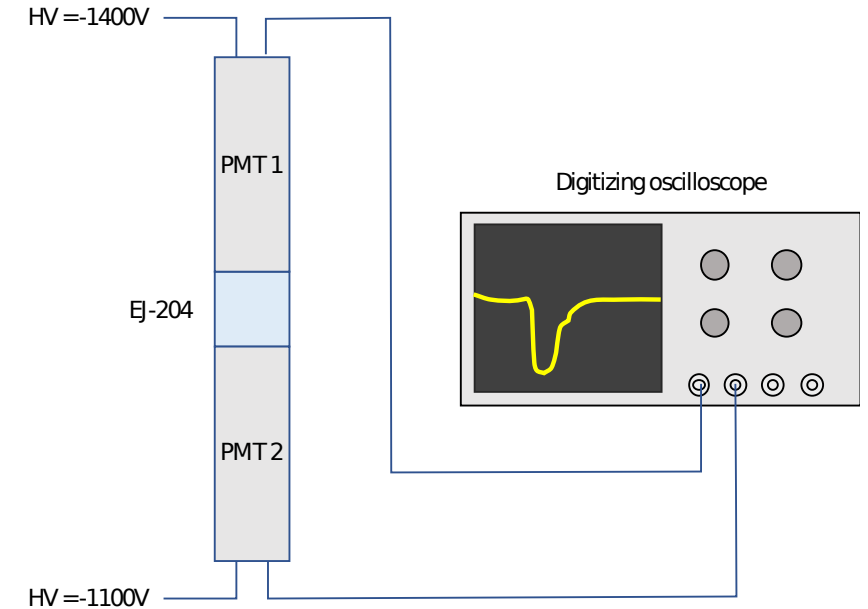
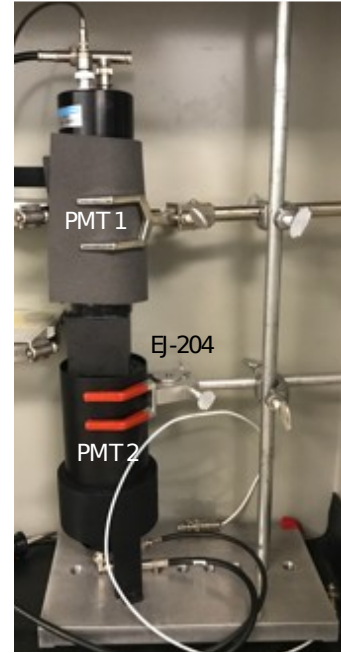

We reconstructed single-site events

- Collimated ^{133}Ba beam
- Single-site event fit
- 10 data sets of 1000 events
- Fit: Reduced χ^2 (ROOT Minuit2) 4 free parameters seeded with “best fit” voxel

^{137}Cs energy reconstruction is in good agreement with the scintillation properties of EJ-204

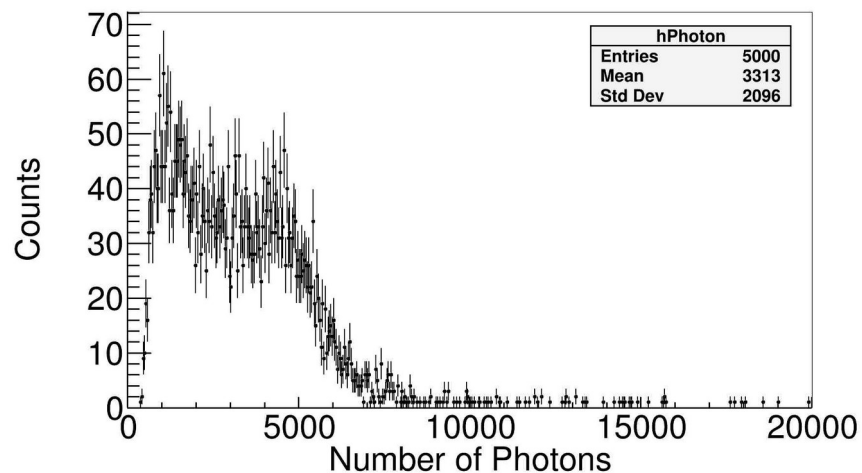

Reconstructed kinematic edge of DT-neutrons in the monolithic cube using single-site fit algorithm

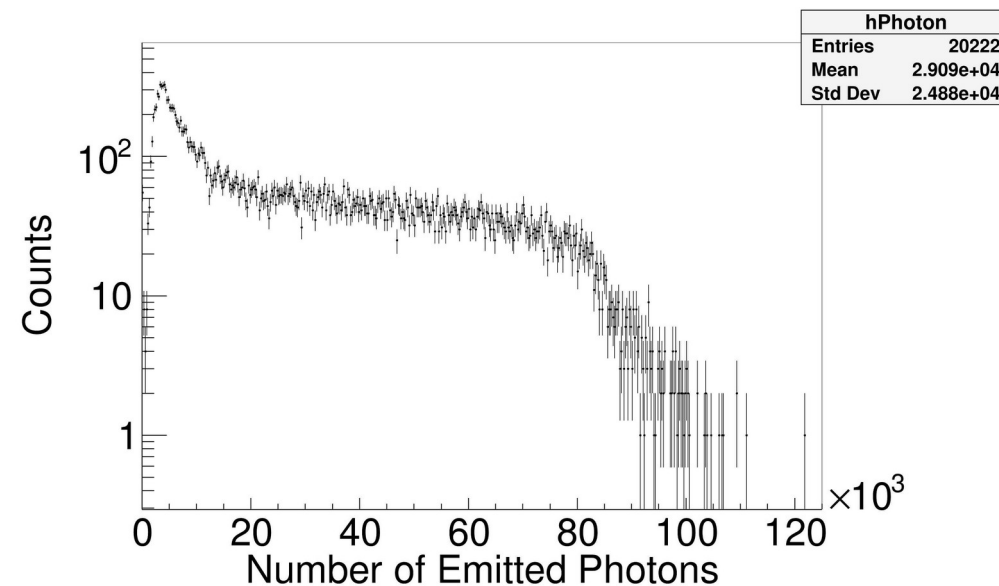
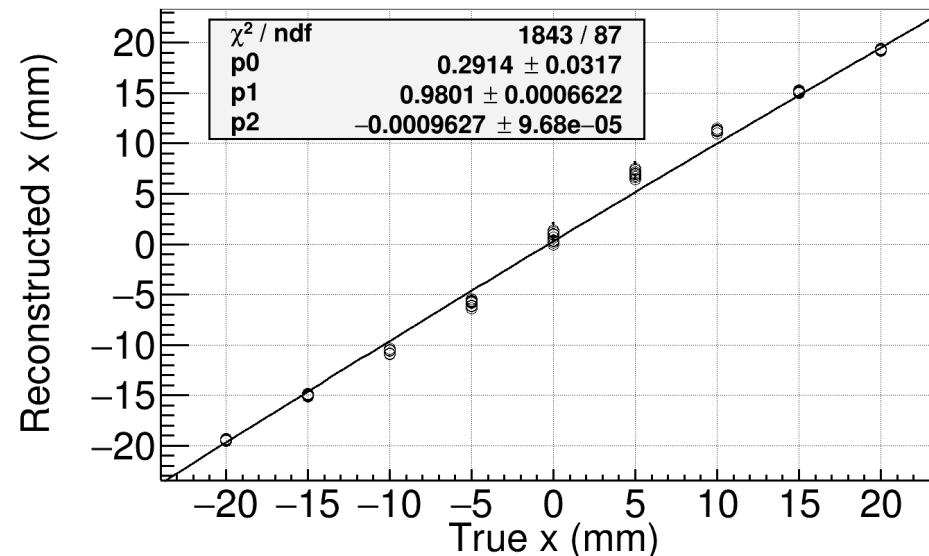

Moving on to double-site events

1) Select and record data enriched in double scatters

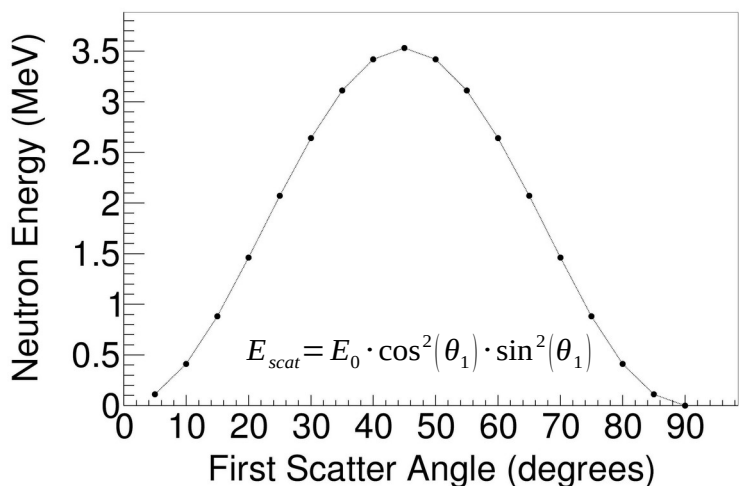
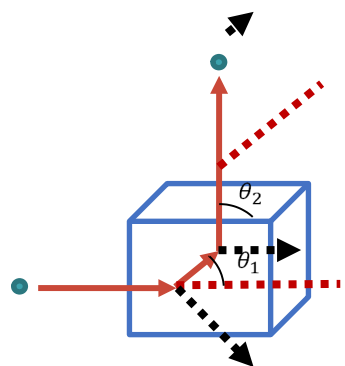

$E_{\text{dep}} > 10$ MeV in cube,
 $E_{\text{dep}} > 1$ MeV in scatter detector

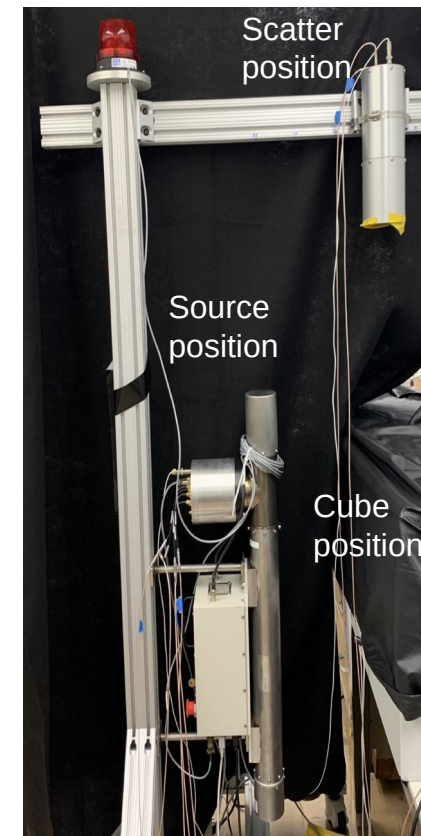
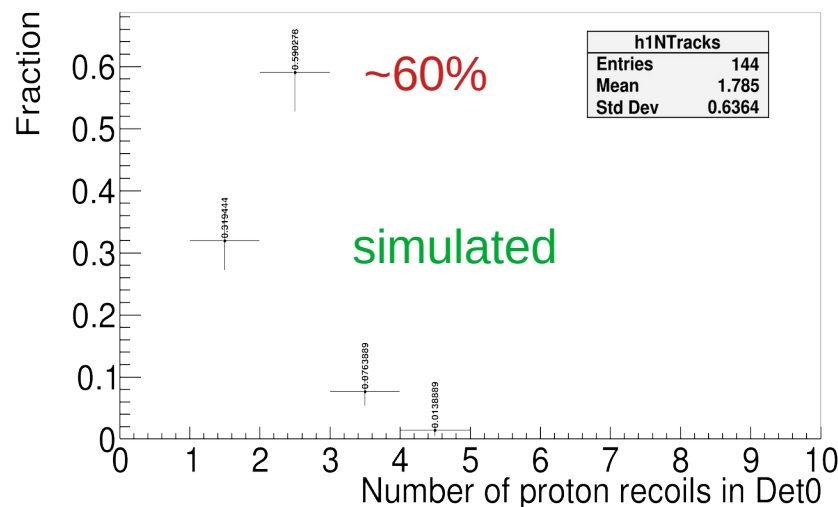

2) Reconstruct events as both single and double hits and select those with better “fitted” result

Reduced χ^2 calculation on simulated 2-site events with single and double site algorithm

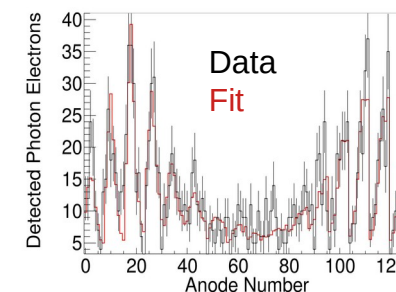
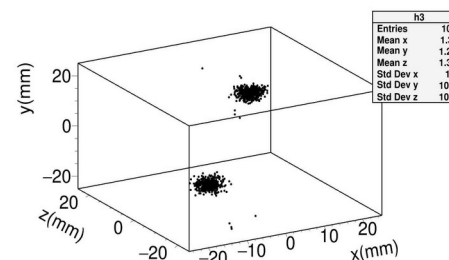
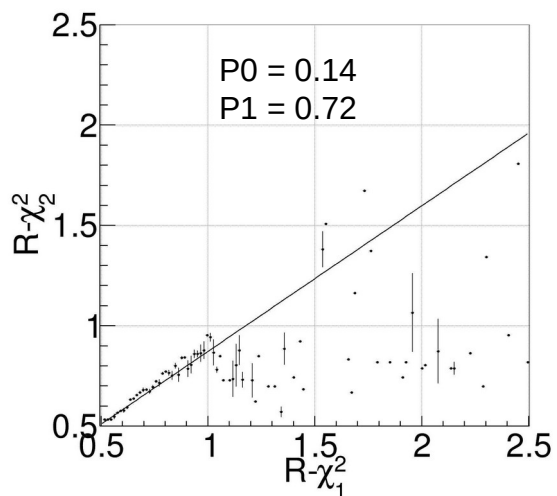

3) Check that everything agrees (reconstructed energy, distance between points, and angle)

Current results

- Single-site position reconstruction was successful, reconstructing both the number of photons emitted and (x,y,z)
- Developed a model which includes reflections at the boundaries and achieved good agreement to single-site experimental data
- Uncertainty quantification of recorded hit distributions for individual anodes was calculated accounting for observed crosstalk in the optical sensor
- Double-site fitting algorithm was applied to enriched neutron double interaction site data
- Preliminary results indicate that our method works for the right 2-site data, but also will “work” for data that are not true 2-site events

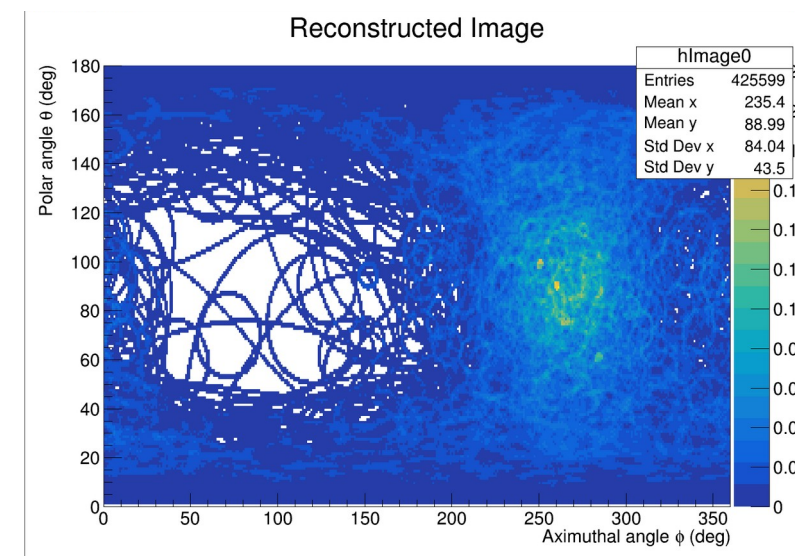
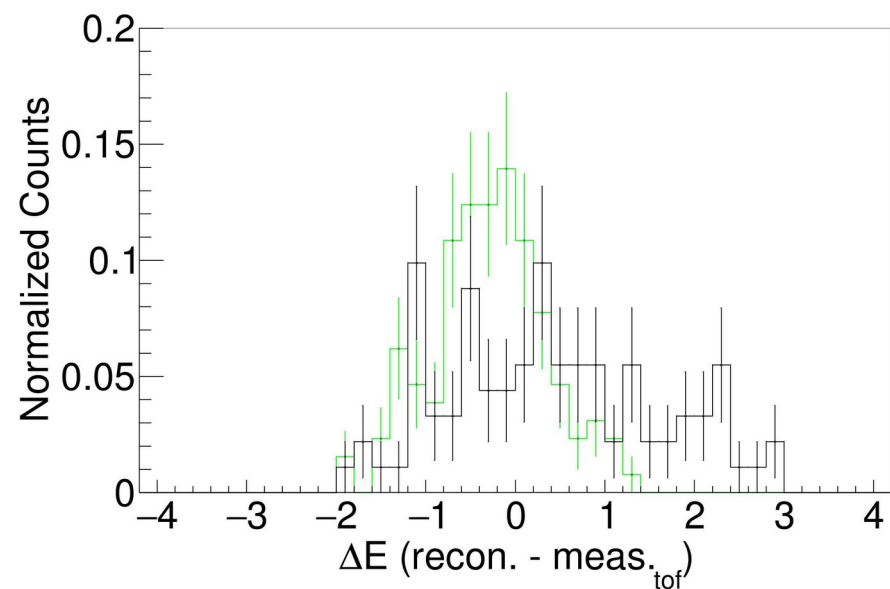
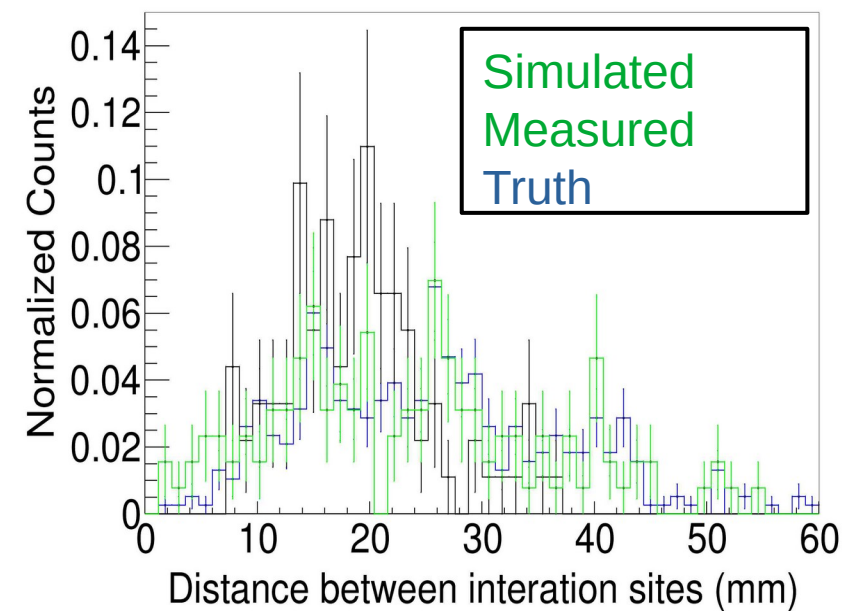
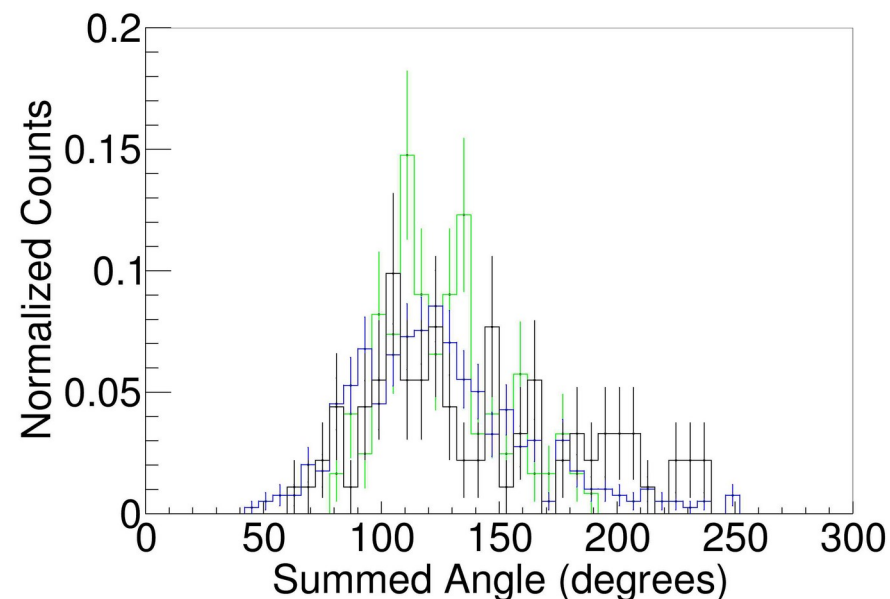

Simple backprojection

† J. A. Brown ^a, E. Brubaker ^a, B. Cabrera-Palmer ^a, J. Carlson ^a, R. Dorrill ^b, A. Druetzler ^b, J. Elam ^c, M. Febbraro ^d, P. Feng ^a, M. Folsom ^d, A. Galino-Tellez ^b, B. L. Goldblum ^e, P. Hausladen ^d, N. Kaneshige ^b, K. Keefe ^b, T. A. Laplace ^e, J. G. Learned ^b, A. Mane ^c, J. J. Manfredi ^e, P. Marleau ^a, J. Mattingly ^f, M. Mishra ^f, A. Moustafa ^f, J. Nattress ^d, K. Nishimura ^b, J. Steele ^a, M. Sweany ^a, K. Weinfurther ^f, K. Ziock ^d

^aSandia National Laboratory, Livermore, CA 94550, USA

^bUniversity of Hawai'i at Manoa, Honolulu, HI 96822, USA

^cArgonne National Laboratory, Lemont, IL 60439, USA

^dOak Ridge National Laboratory, Oak Ridge, TN 37831, USA

^eUniversity of California, Berkeley, CA 94720, USA

^fNorth Carolina State University, Raleigh, NC 27695, USA