

# Searching for sub- $\mu\text{eV}$ axions with DMRadio

Nicholas Rapidis

Stanford University – Irwin Group

ORNL – June 4<sup>th</sup> 2026

# The Standard Model of Particle Physics

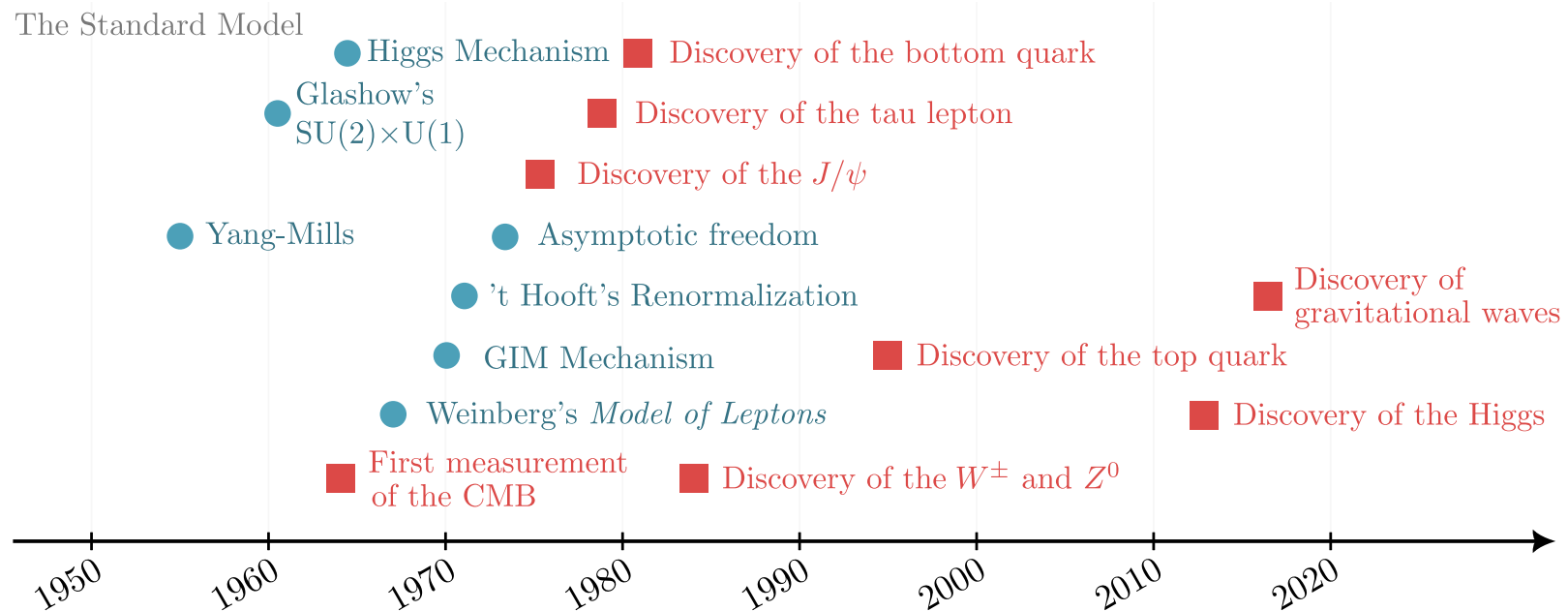

# The Standard Model of Particle Physics and its problems

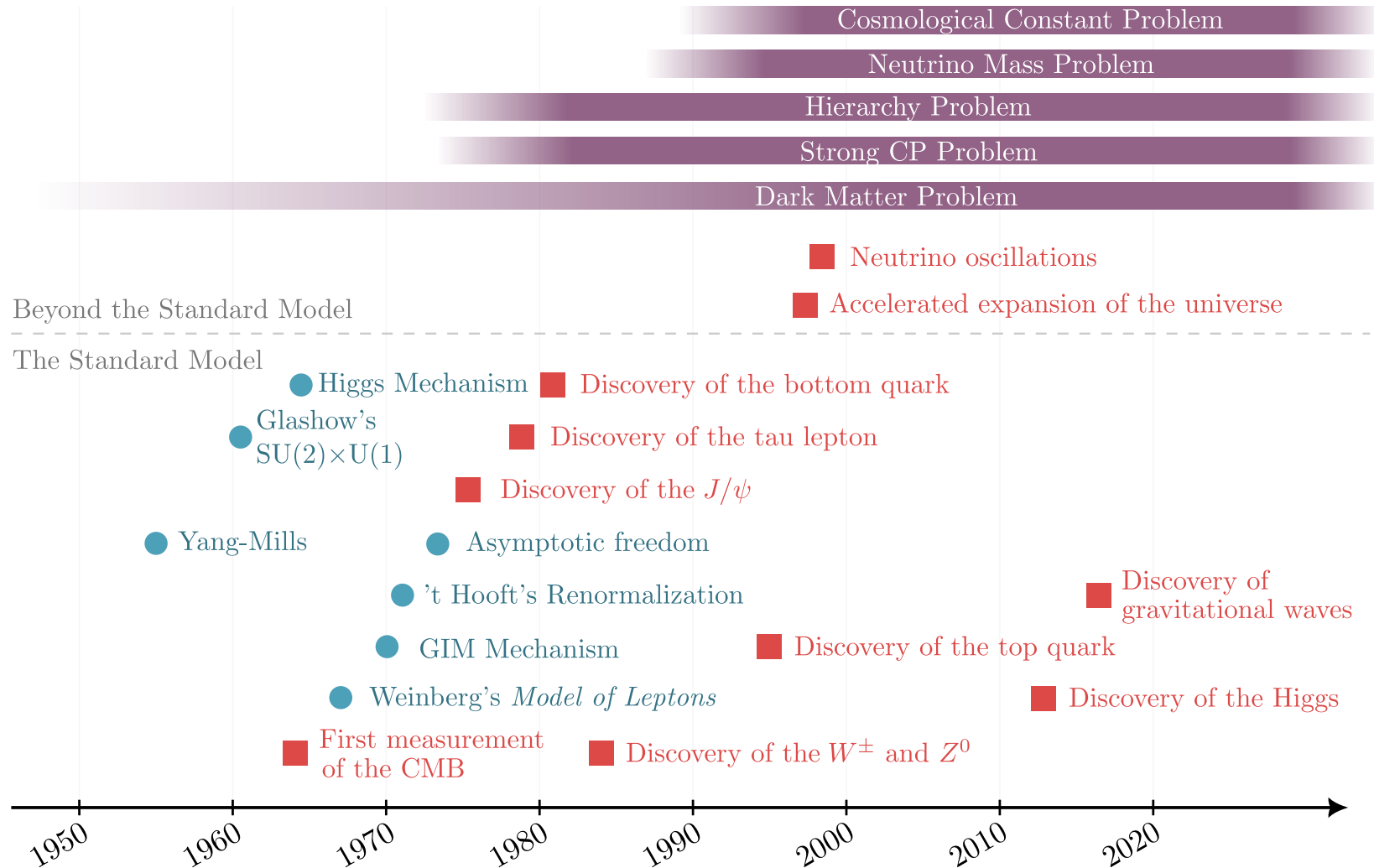

# The Standard Model of Particle Physics and its problems



*“dark matter axions”*

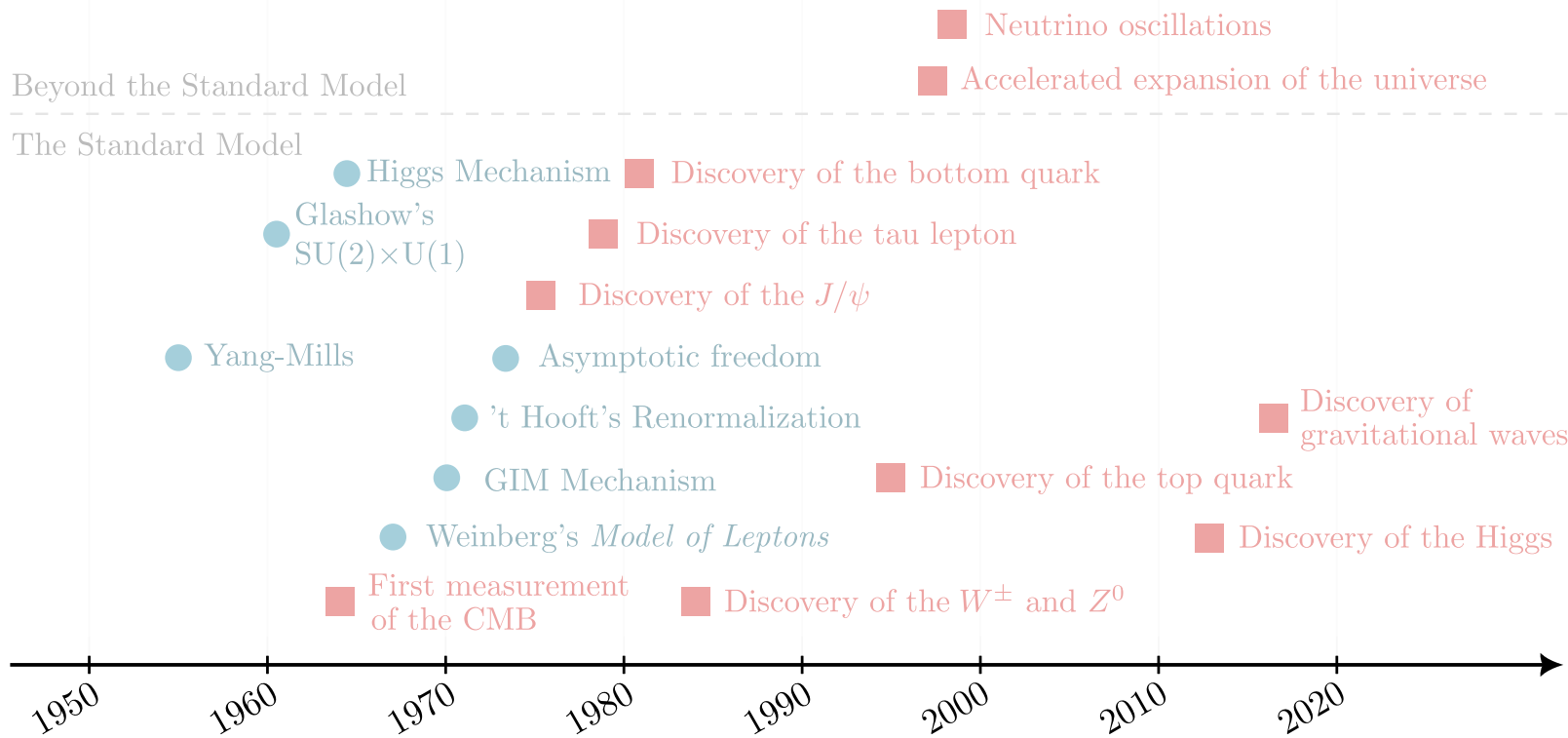

# Outline

Strong CP problem

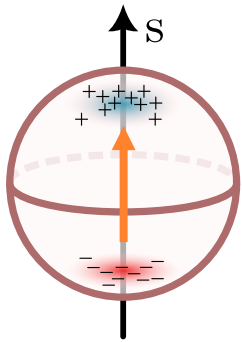

Dark matter



Dark matter axions

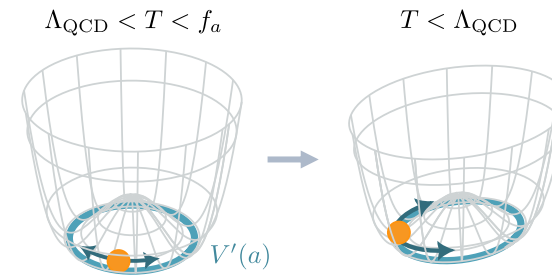

Axion-Standard Model interactions

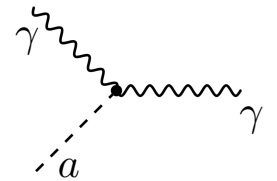

## DMRadio

Ongoing implementation

Designs of next generation

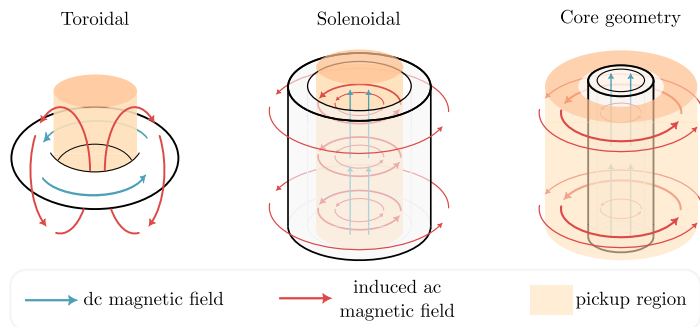

DMRadio-50L

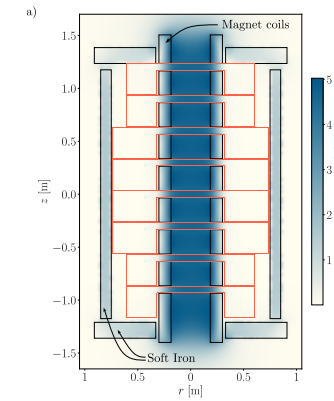
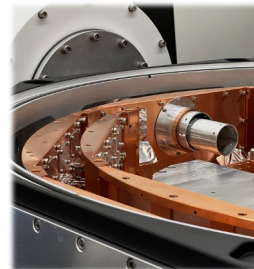

DMRadio-Core, DMRadio-GUT

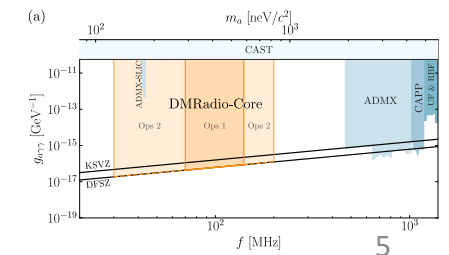

# Outline

Strong CP problem

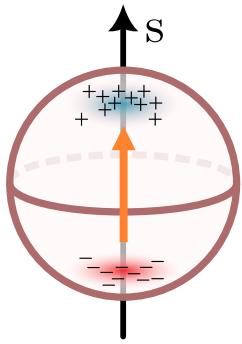

Dark matter



Dark matter axions

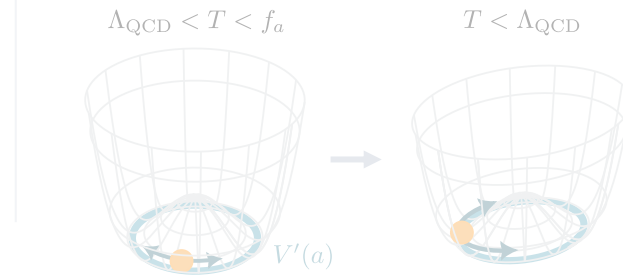

Axion-Standard Model interactions

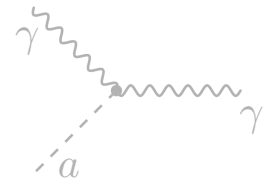

DMRadio

Ongoing implementation

Designs of next generation

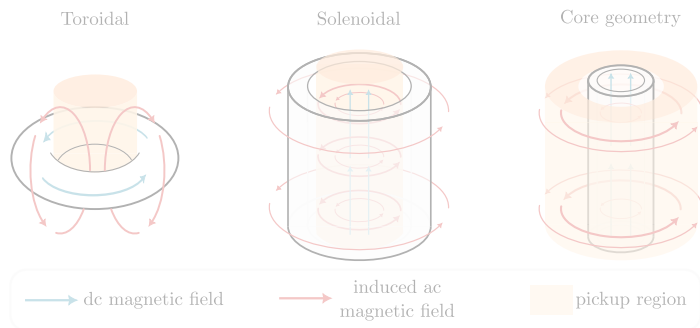

DMRadio-50L

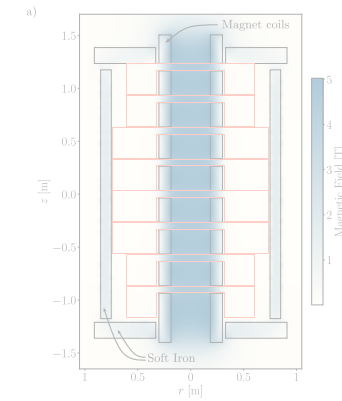
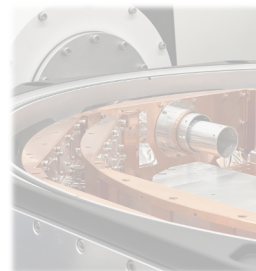

DMRadio-Core, DMRadio-GUT

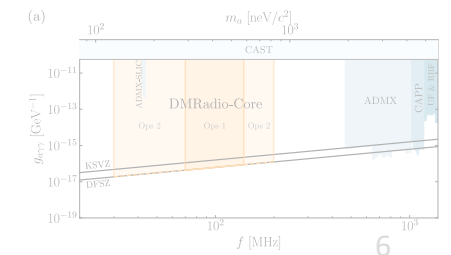

# Strong CP problem

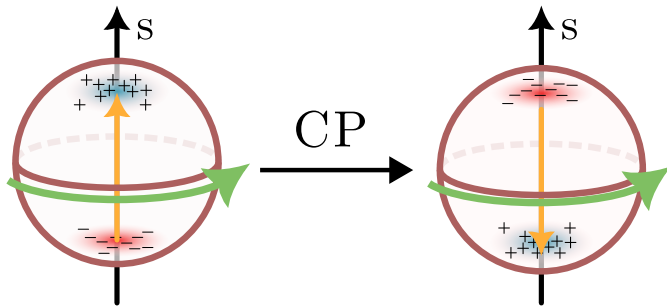

The neutron can have an *electric dipole moment (edm)*.

Under a charge (C) and parity flip (P), the neutron no longer looks the same for a non-zero edm.

# Strong CP problem

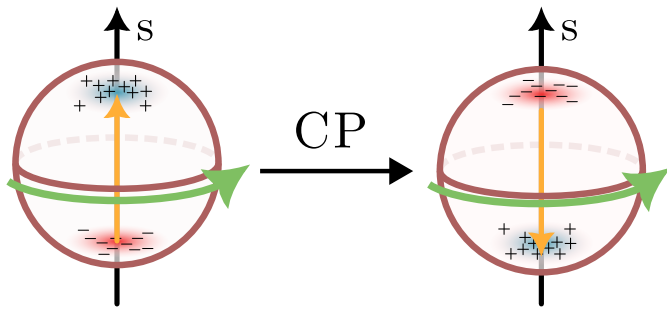

The neutron can have an *electric dipole moment (edm)*.

Under a charge (C) and parity flip (P), the neutron no longer looks the same for a non-zero edm.

The neutron edm is quantified by  $\bar{\theta}$ . This is a free parameter in the standard model

Expect:  $0 \leq \bar{\theta} < 2\pi$



# Strong CP problem

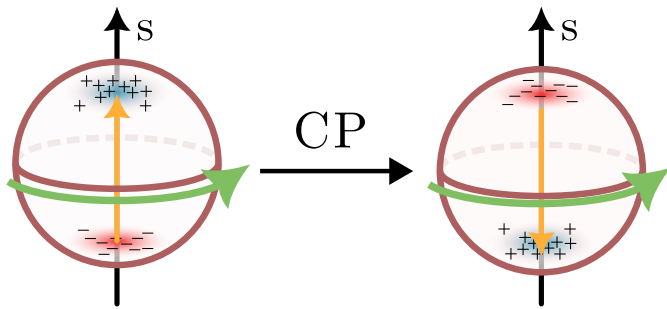

The neutron can have an *electric dipole moment (edm)*.

Under a charge (C) and parity flip (P), the neutron no longer looks the same for a non-zero edm.

The neutron edm is quantified by  $\bar{\theta}$ . This is a free parameter in the standard model

$$\text{Expect: } 0 \leq \bar{\theta} < 2\pi$$



$$\text{Measurement: } \bar{\theta} \lesssim 10^{-10}$$

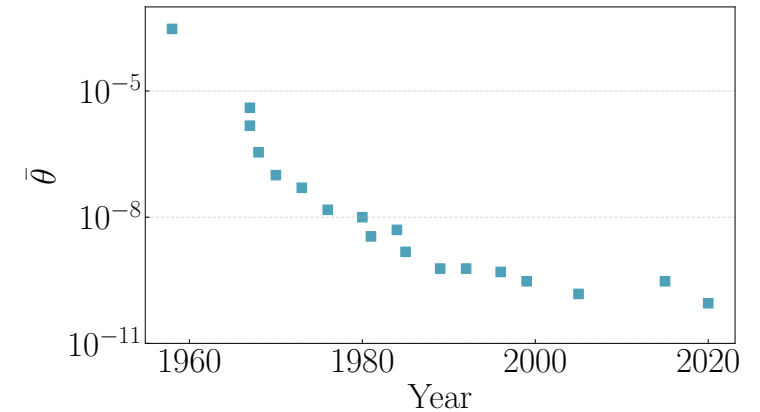

The theory has no reason to prefer  $\bar{\theta} = 0$ . We end up in a universe that has no CP violation in the strong sector.

This is a fine tuning

**The Strong CP problem**

This cannot be solved with anthropics!

# Outline

Strong CP problem

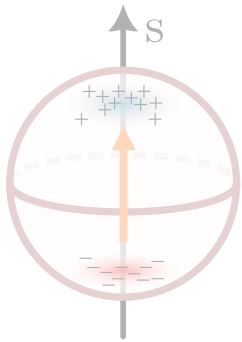

Dark matter



Dark matter axions

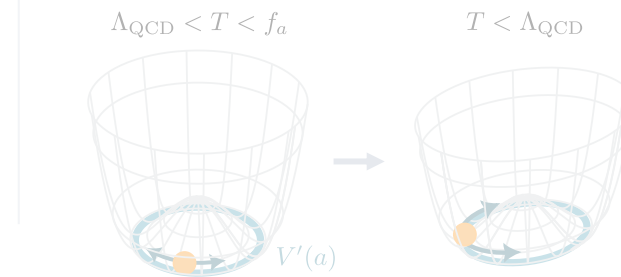

Axion-Standard Model interactions

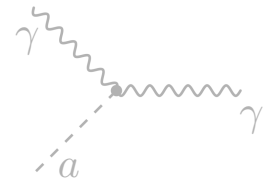

DMRadio

Ongoing implementation

Designs of next generation

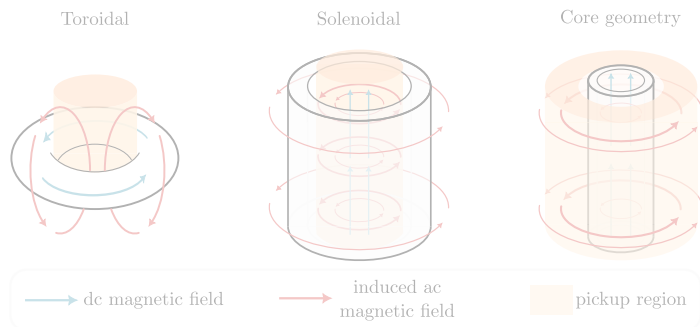

DMRadio-50L

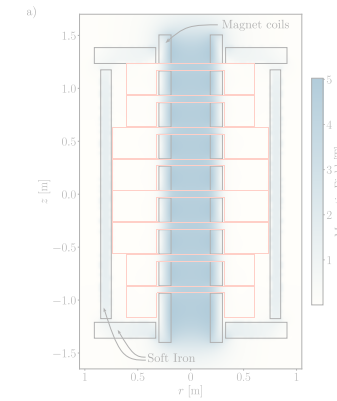
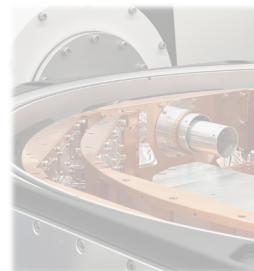

DMRadio-Core, DMRadio-GUT

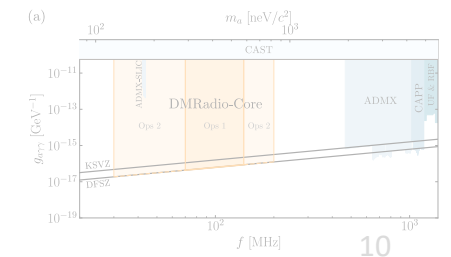

# Dark matter

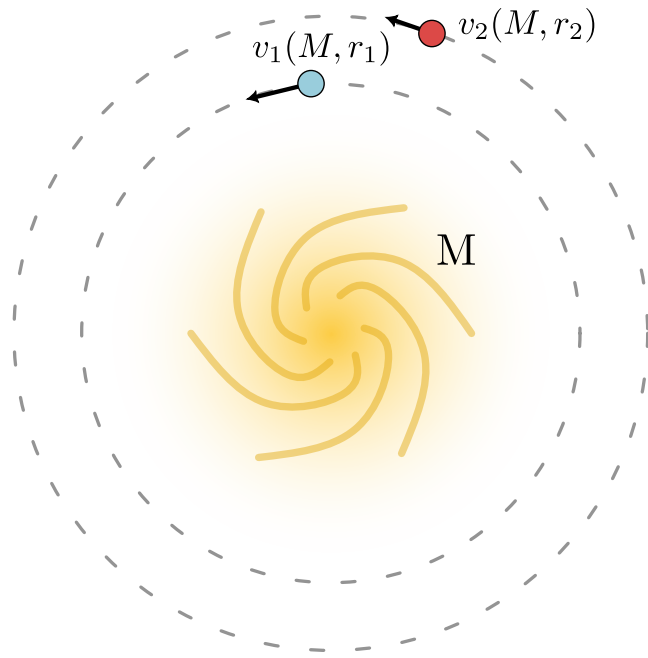

Newtonian mechanics predicts:

$$\left. \begin{aligned} F_g &= G \frac{Mm}{r^2} \\ F_c &= \frac{mv^2}{r} \end{aligned} \right\} v \sim 1/\sqrt{r}$$

# Dark matter

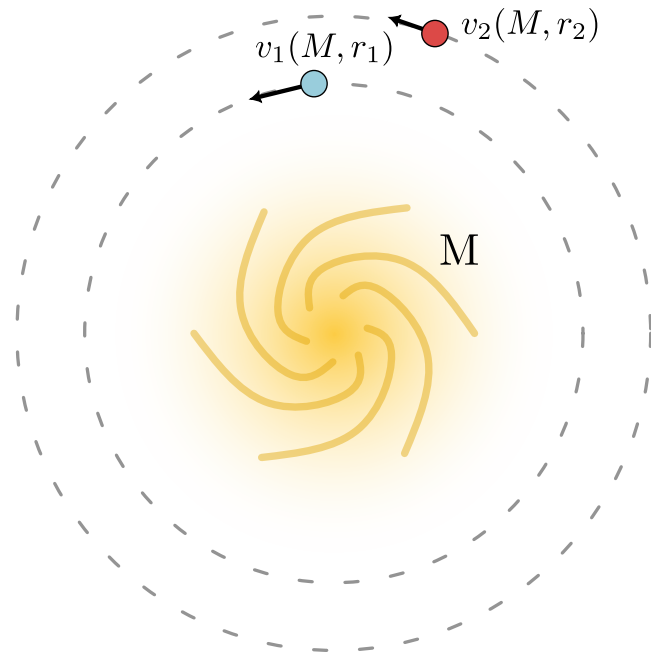

Expectation:

UGC11455 galaxy, figure modified from Wikipedia

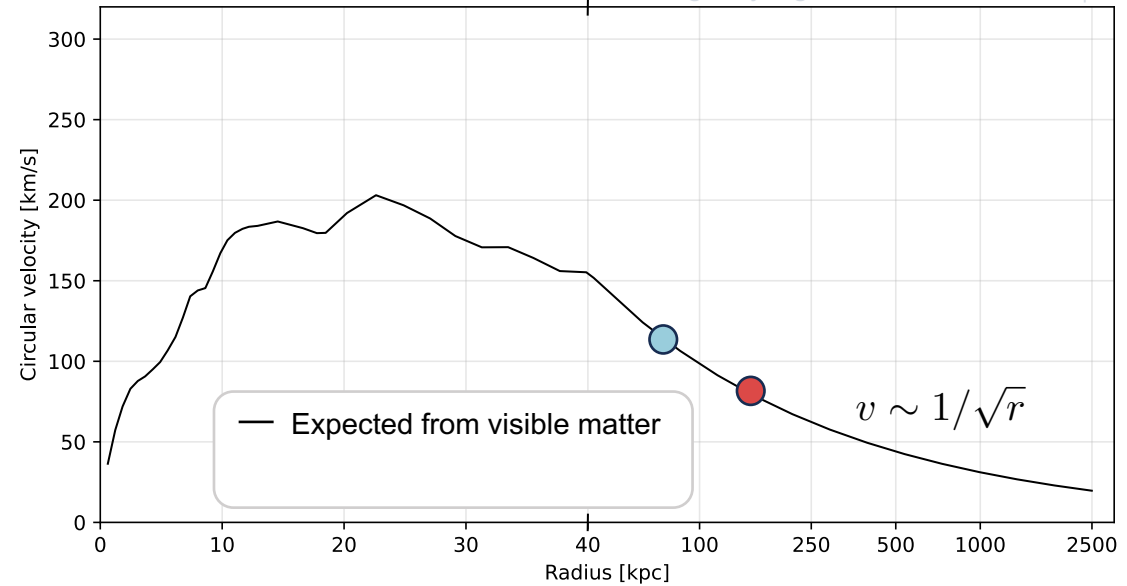

Newtonian mechanics predicts:

$$\left. \begin{aligned} F_g &= G \frac{Mm}{r^2} \\ F_c &= \frac{mv^2}{r} \end{aligned} \right\} v \sim 1/\sqrt{r}$$

# Dark matter

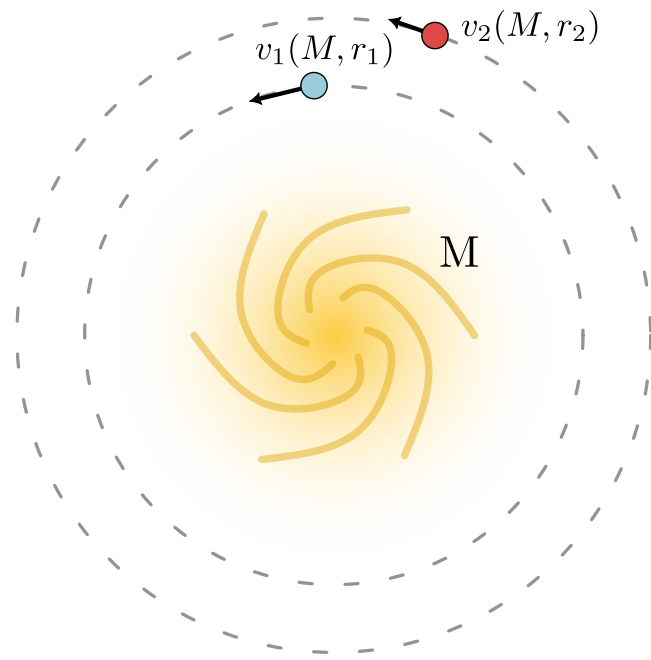

Newtonian mechanics predicts:

$$\left. \begin{aligned} F_g &= G \frac{Mm}{r^2} \\ F_c &= \frac{mv^2}{r} \end{aligned} \right\} v \sim 1/\sqrt{r}$$

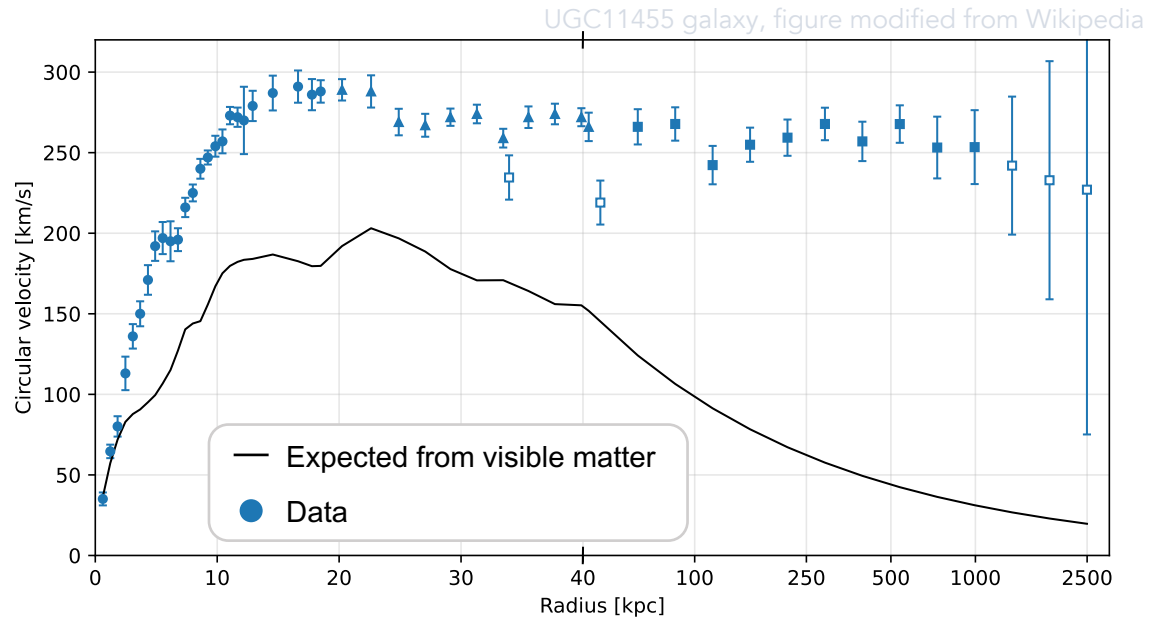

Galaxies spin much faster than they should, given amount of visible matter!

Solutions:

Newtonian dynamics are inaccurate at large distances

There's undetected **dark matter** in the galaxy

# Dark matter

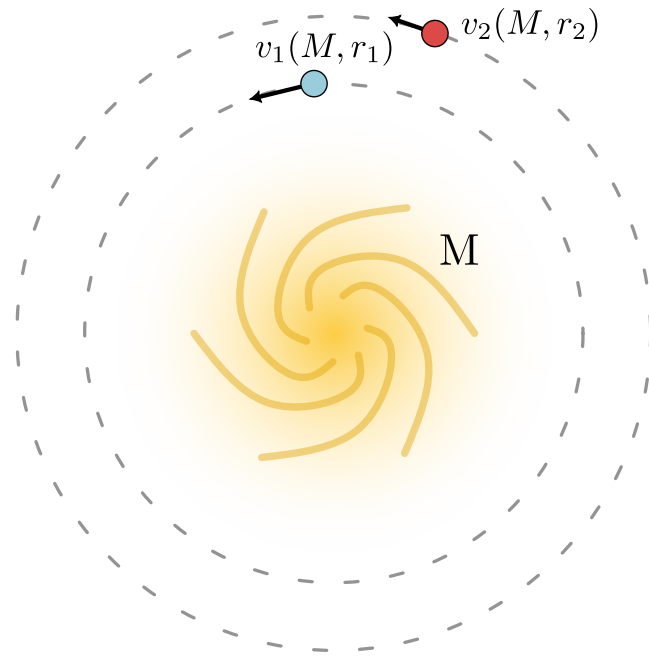

Newtonian mechanics predicts:

$$\left. \begin{aligned} F_g &= G \frac{Mm}{r^2} \\ F_c &= \frac{mv^2}{r} \end{aligned} \right\} v \sim 1/\sqrt{r}$$

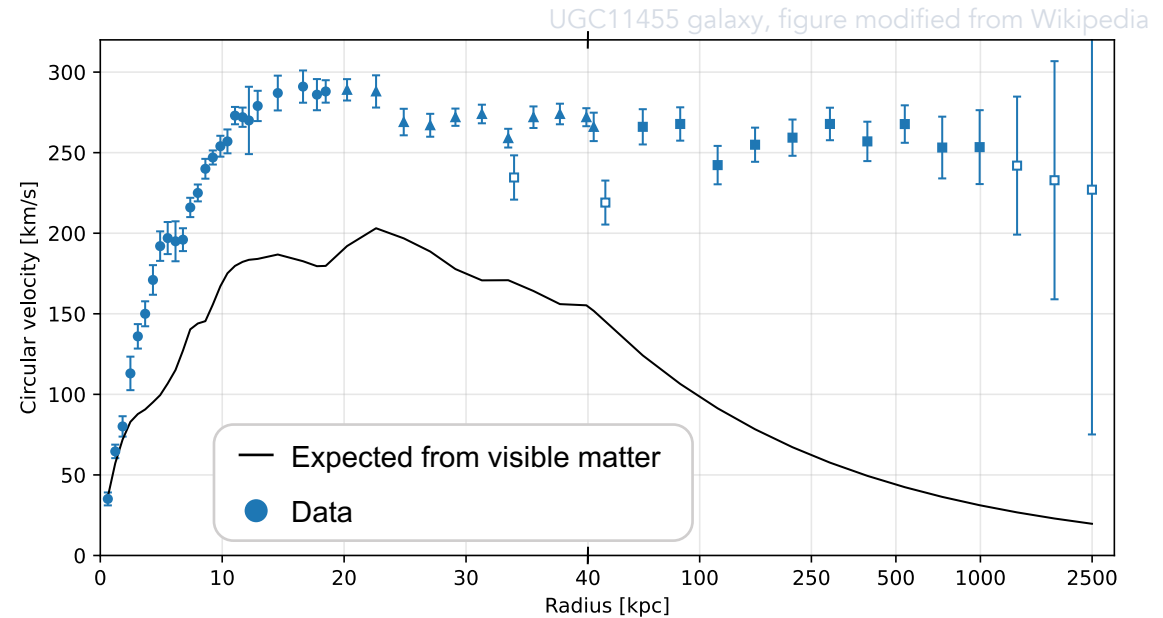

Galaxies spin much faster than they should, given amount of visible matter!

Solutions:

~~Newtonian dynamics are inaccurate at large distances~~

There's undetected **dark matter** in the galaxy

# Further proof of dark matter

Bullet cluster:

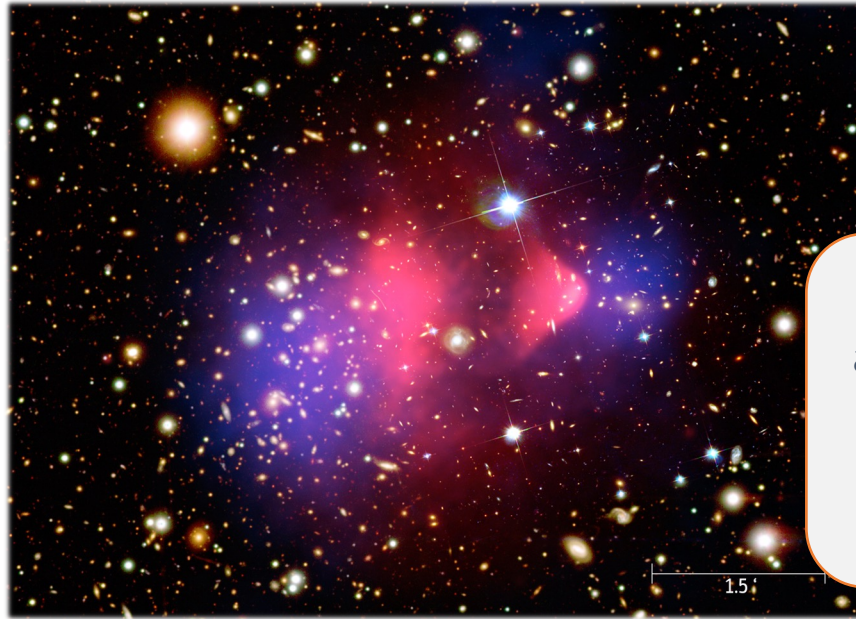

Bullet Cluster, NASA

mass density, x-ray density

Dark matter exists in universe and is very weakly interacting!

It is ~80% of the mass in the universe!

Galaxy clusters collided. Ordinary matter interacted and produced x-rays, dark matter streamed through

CMB power spectrum:

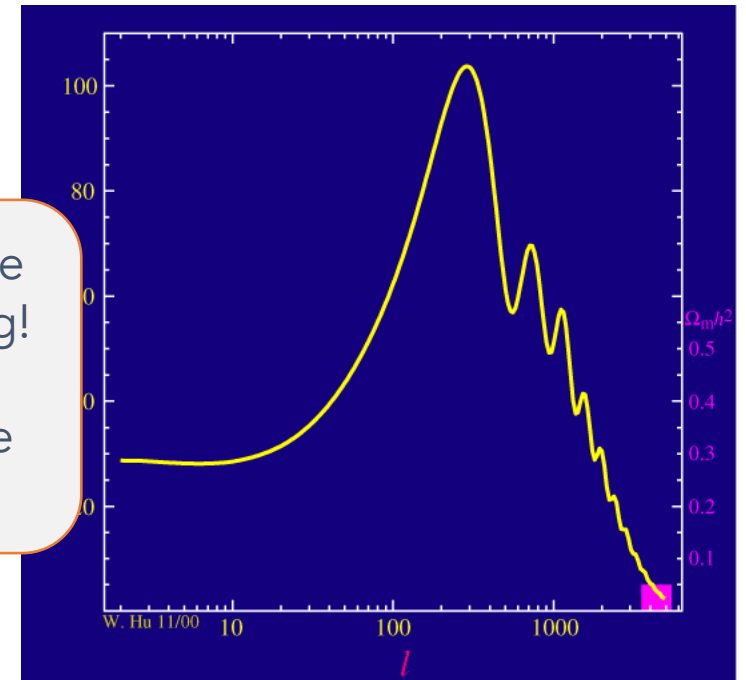

Wayne Hu, <https://background.uchicago.edu/~whu/animbut/anim2.html>

Additional non-baryonic matter must be introduced to explain CMB power spectrum

# Outline

Strong CP problem

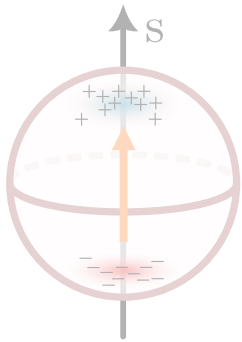

Dark matter



Dark matter axions

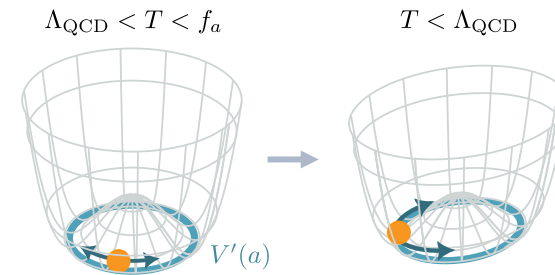

Axion-Standard Model interactions

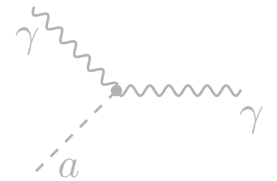

DMRadio

Ongoing implementation

Designs of next generation

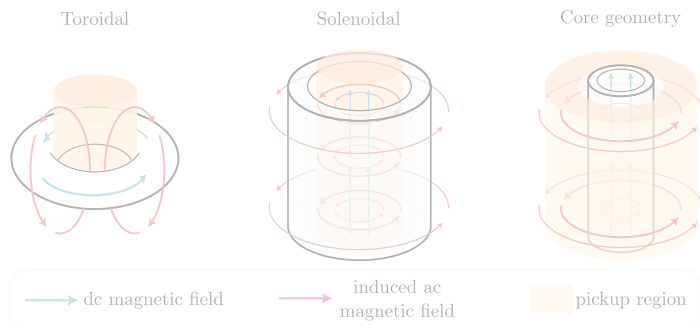

DMRadio-50L

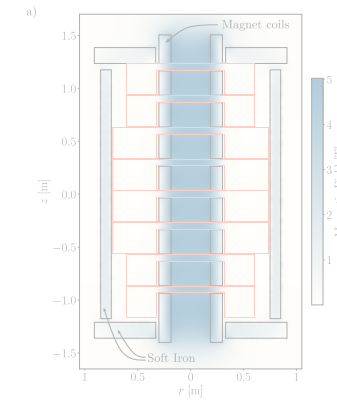
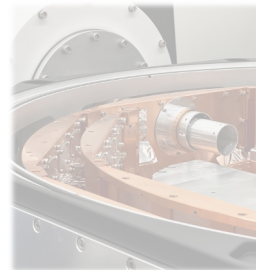

DMRadio-Core, DMRadio-GUT

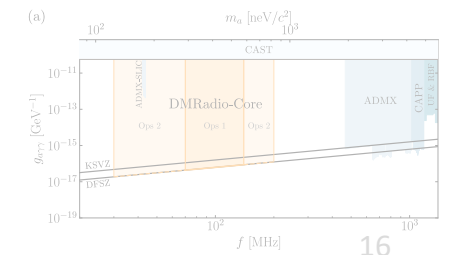

# Solution to the strong CP problem

Strong CP problem is introduced by:

$$\mathcal{L}_{\text{CP}} = \frac{\bar{\theta}}{32\pi^2} G_{\mu\nu}^a \tilde{G}^{a\mu\nu}$$

# Solution to the strong CP problem

Strong CP problem is introduced by:

$$\mathcal{L}_{\text{CP}} = \frac{\bar{\theta}}{32\pi^2} G_{\mu\nu}^a \tilde{G}^{a\mu\nu}$$

Introduce a new U(1) symmetry that is broken at a scale  $f_a$ .

This introduces a new particle, **the axion**, which couples as:

$$\mathcal{L}_{\text{CP}} = \frac{1}{32\pi^2} \left( \bar{\theta} + \frac{a}{f_a} \right) G_{\mu\nu}^a \tilde{G}^{a\mu\nu}$$

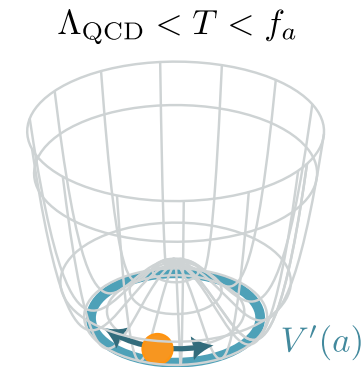

Peccei, Quinn (1977)  
Weinberg, Wilczek (1978)

# Solution to the strong CP problem

Strong CP problem is introduced by:

$$\mathcal{L}_{\text{CP}} = \frac{\bar{\theta}}{32\pi^2} G_{\mu\nu}^a \tilde{G}^{a\mu\nu}$$

Introduce a new U(1) symmetry that is broken at a scale  $f_a$ .

This introduces a new particle, **the axion**, which couples as:

$$\mathcal{L}_{\text{CP}} = \frac{1}{32\pi^2} \left( \bar{\theta} + \frac{a}{f_a} \right) G_{\mu\nu}^a \tilde{G}^{a\mu\nu}$$

Below,  $\Lambda_{\text{QCD}}$ , axion develops **potential**, becomes massive, and solves strong CP problem

$$\left( \bar{\theta} + \frac{a}{f_a} \right) = 0$$

$$\Lambda_{\text{QCD}} < T < f_a$$

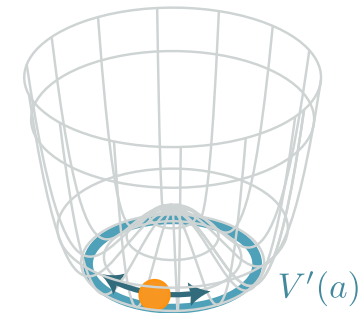

Peccei, Quinn (1977)  
Weinberg, Wilczek (1978)

$$T < \Lambda_{\text{QCD}}$$

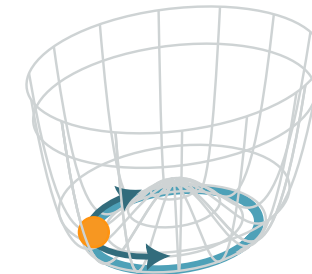

# Cosmological properties of axions

Symmetry breaking happens at high energies so axion **must be produced** in the early universe

# Cosmological properties of axions

Symmetry breaking happens at high energies so axion **must be produced in the early universe**

Axions must be produced athermally, so they **must be non-relativistic (cold)**

# Cosmological properties of axions

Symmetry breaking happens at high energies so axion **must be produced in the early universe**

Axions must be produced athermally, so they **must be non-relativistic (cold)**

Axions can be **produced in abundance**

# Cosmological properties of axions

Symmetry breaking happens at high energies so axion **must be produced in the early universe**

Axions must be produced athermally, so they **must be non-relativistic (cold)**

Axions can be **produced in abundance**

Axions can **couple weakly to standard model particles**

# Cosmological properties of axions

Symmetry breaking happens at high energies so axion **must be produced in the early universe**

Axions must be produced athermally, so they **must be non-relativistic (cold)**

Axions can be **produced in abundance**

Axions can **couple weakly to standard model particles**

**This is dark matter**

# Cosmological properties of axions

Symmetry breaking happens at high energies so axion **must be produced in the early universe**

Axions must be produced athermally, so they **must be non-relativistic (cold)**

Axions can be **produced in abundance**

Axions can **couple weakly to standard model particles**

**This is dark matter**

## Pre-inflationary PQ symmetry breaking

Fluctuations during inflation provide non-zero  $\theta_{\text{eff}}$  after inflation

$$m_a \text{ as low as } < \text{neV}$$

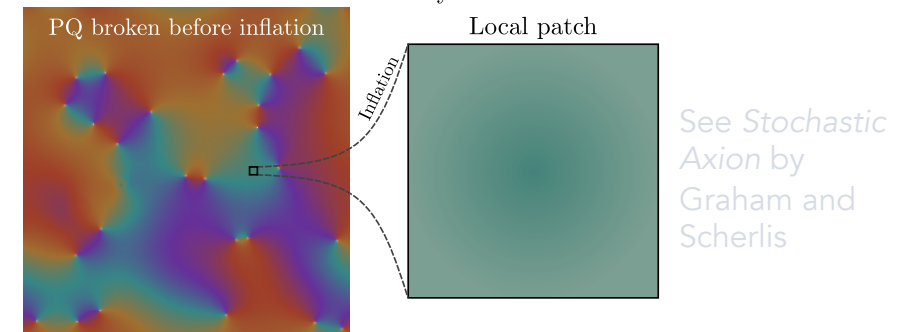

## Post-inflationary PQ symmetry breaking

$\theta_{\text{QCD}}$  is random between causally disconnected patches; strings (and domain walls) form

$$1 \mu\text{eV} \lesssim m_a \lesssim 1 \text{meV}$$

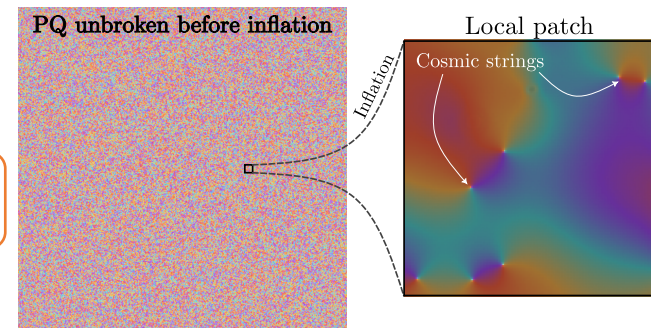

# Axions locally, today

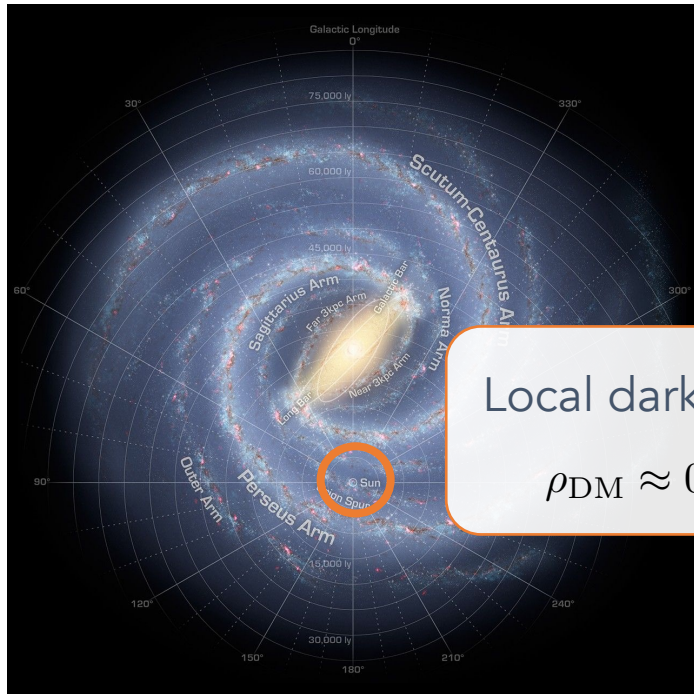

Local dark matter density

$$\rho_{\text{DM}} \approx 0.45 \text{ GeV cm}^{-3}$$

$$n_a \sim 10^{14} \left( \frac{1 \mu\text{eV}}{m_a} \right) \text{ cm}^{-3} \gg 1 \text{ per quantum state}$$

# Axions locally, today

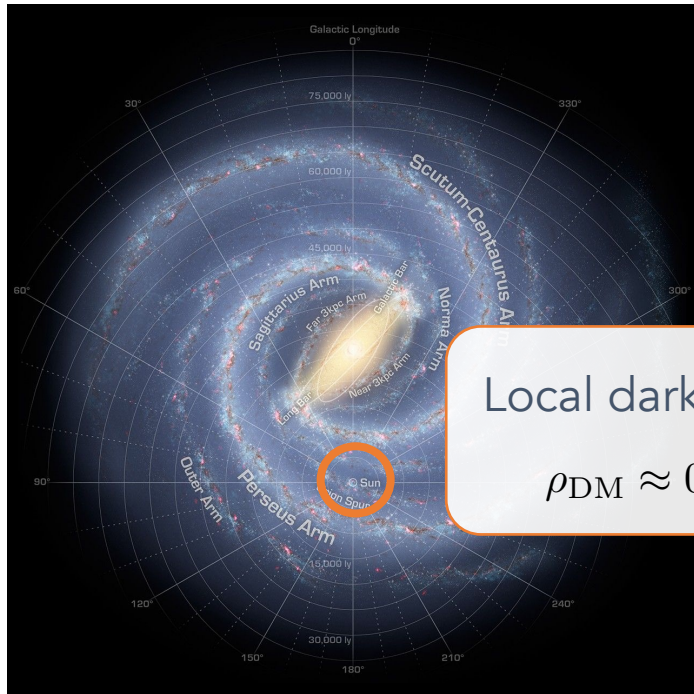

Local dark matter density

$$\rho_{\text{DM}} \approx 0.45 \text{ GeV cm}^{-3}$$

Axion can be modeled as **classical wave** whose:

- Amplitude is set by local dark matter density
- Frequency is set by its mass ( $\nu_a = m_a c^2 / h$ )
- Phase set by dark matter dynamics

$$n_a \sim 10^{14} \left( \frac{1 \mu\text{eV}}{m_a} \right) \text{ cm}^{-3} \gg 1 \text{ per quantum state}$$

# Outline

Strong CP problem

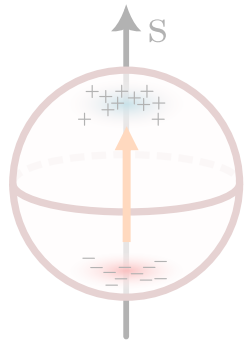

Dark matter



Dark matter axions

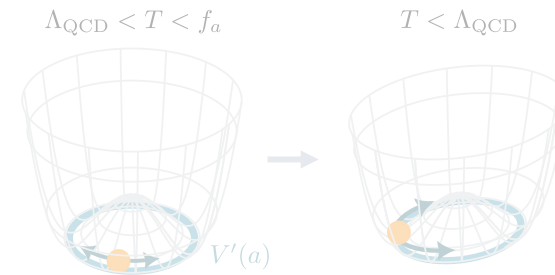

Axion-Standard Model interactions

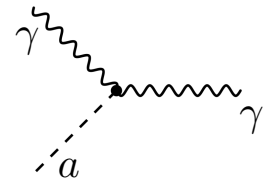

DMRadio

Ongoing implementation

Designs of next generation

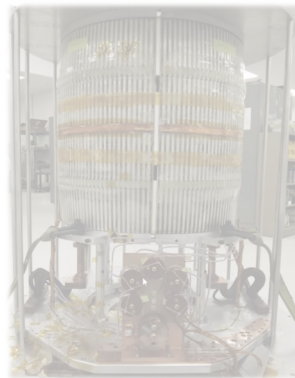
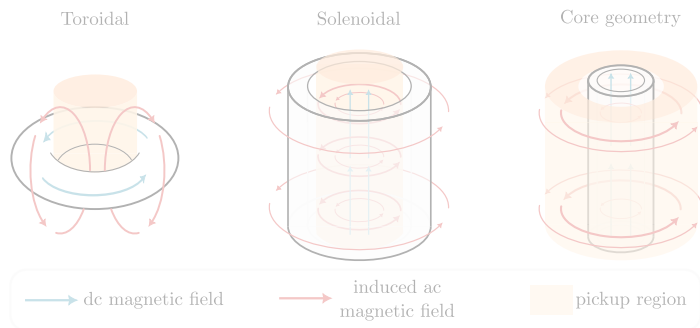

DMRadio-50L

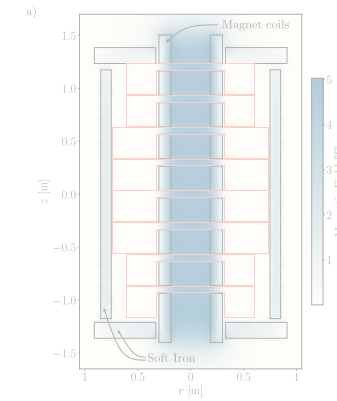
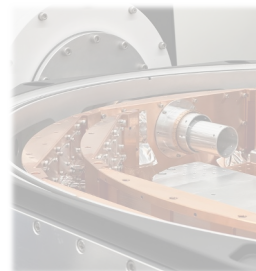

DMRadio-Core, DMRadio- $m^3$ , DMRadio-GUT

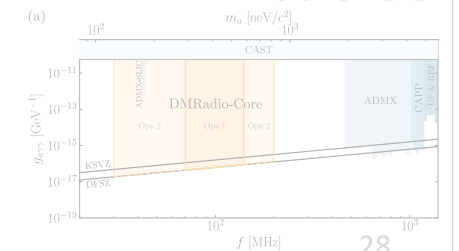

# Axion electrodynamics

Axions modify Maxwell's equations:

$$\nabla \cdot \vec{E} = 0$$

$$\nabla \cdot \vec{B} = 0$$

$$\nabla \times \vec{E} = -\partial_t \vec{B}$$

$$\nabla \times \vec{B} = \partial_t \vec{E} + g_{a\gamma\gamma} \partial_t a \vec{B}$$

(source free)

Applied dc  
magnetic field

$$\mathcal{L}_{\text{int}} \sim g_{a\gamma\gamma} a F_{\mu\nu} \tilde{F}^{\mu\nu}$$

# Axion electrodynamics

Axions modify Maxwell's equations:

$$\nabla \cdot \vec{E} = 0$$

$$\nabla \cdot \vec{B} = 0$$

$$\nabla \times \vec{E} = -\partial_t \vec{B}$$

$$\nabla \times \vec{B} = \partial_t \vec{E} + g_{a\gamma\gamma} \partial_t a \vec{B}$$

(source free)

Applied dc  
magnetic field

$$\mathcal{L}_{\text{int}} \sim g_{a\gamma\gamma} a F_{\mu\nu} \tilde{F}^{\mu\nu}$$

This acts as an effective current density:

$$\vec{J}_{\text{eff}}(\mathbf{x}, t) = g_{a\gamma\gamma} \sqrt{2\rho_{\text{DM}}} \cos(m_a t) \vec{B}_{\text{dc}}(\mathbf{x})$$

↙ Axion mass is  
unknown

# Axion electrodynamics

Axions modify Maxwell's equations:

$$\nabla \cdot \vec{E} = 0$$

$$\nabla \cdot \vec{B} = 0$$

$$\nabla \times \vec{E} = -\partial_t \vec{B}$$

$$\nabla \times \vec{B} = \partial_t \vec{E} + g_{a\gamma\gamma} \partial_t a \vec{B}$$

(source free)

Applied dc  
magnetic field

$$\mathcal{L}_{\text{int}} \sim g_{a\gamma\gamma} a F_{\mu\nu} \tilde{F}^{\mu\nu}$$

This acts as an effective current density:

$$\vec{J}_{\text{eff}}(\mathbf{x}, t) = g_{a\gamma\gamma} \sqrt{2\rho_{\text{DM}}} \cos(m_a t) \vec{B}_{\text{dc}}(\mathbf{x})$$

↙ Axion mass is  
unknown

This is the experimental signature!  
We're looking for signals induced by this  
effective current

# Outline

Strong CP problem

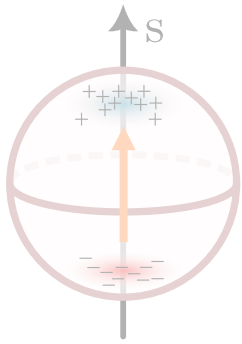

Dark matter



Dark matter axions

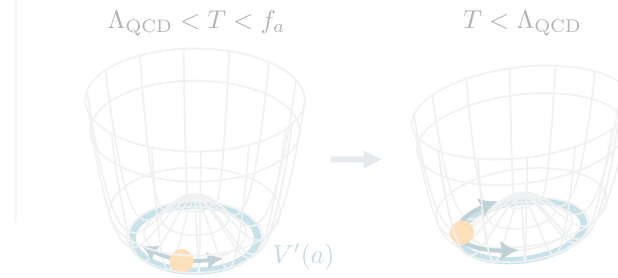

Axion-Standard Model interactions

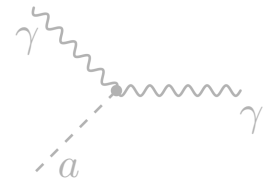

## DMRadio

Ongoing implementation

Designs of next generation

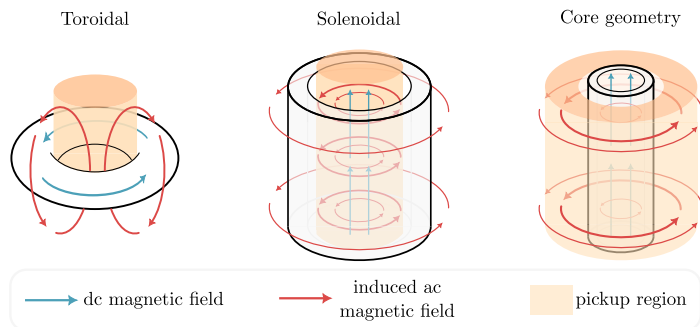

DMRadio-50L

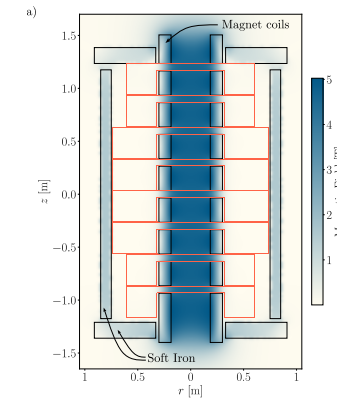
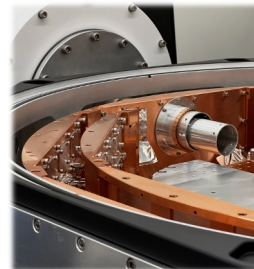

DMRadio-Core, DMRadio-GUT

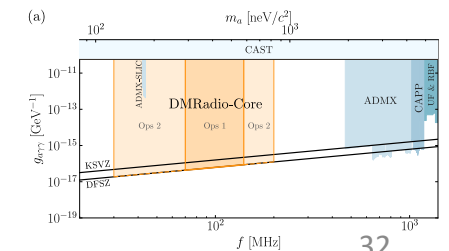

# DMRadio collaboration

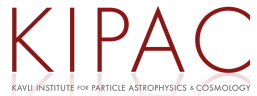

BERKELEY LAB



U.S. DEPARTMENT OF ENERGY

Office of Science



HEISING-SIMONS FOUNDATION

# DMRadio basics: circuit model formalism

At frequencies where wavelength  $\gg$  size of detector (i.e. lumped element regime)

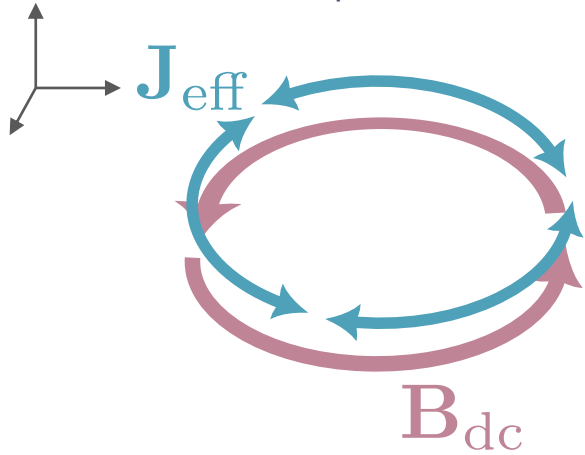

Create **dc magnetic field**, e.g. toroidal magnet

**Axion current** oscillates along magnetic field lines

$$\vec{J}_{\text{eff}}(\mathbf{x}, t) = g_{a\gamma\gamma} \sqrt{2\rho_{\text{DM}}} \cos(m_a t) \vec{B}_{\text{dc}}(\mathbf{x})$$

# DMRadio basics: circuit model formalism

At frequencies where wavelength  $\gg$  size of detector (i.e. lumped element regime)

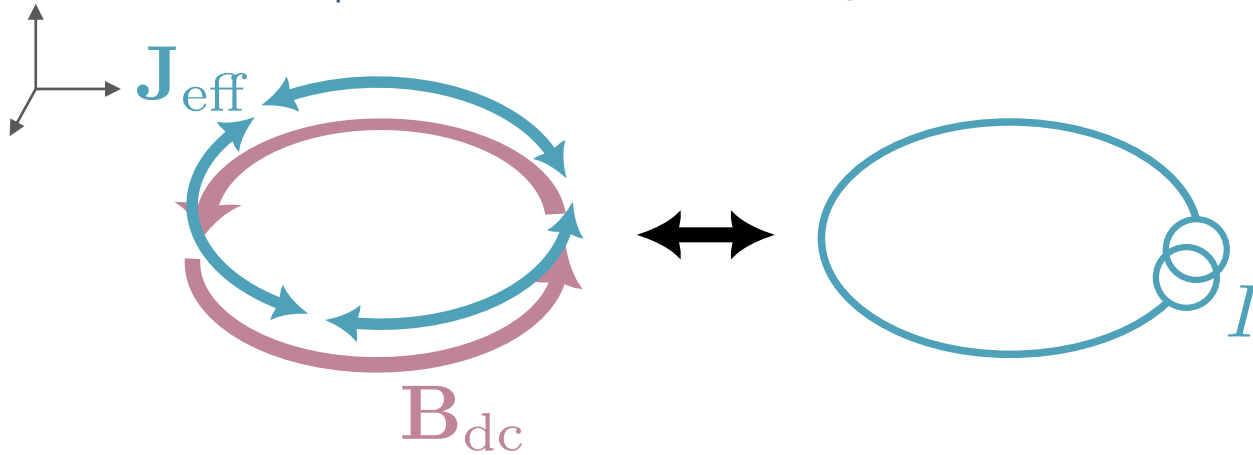

Create **dc magnetic field**, e.g. toroidal magnet

**Axion current** oscillates along magnetic field lines

$$\vec{J}_{eff}(\mathbf{x}, t) = g_{a\gamma\gamma} \sqrt{2\rho_{DM}} \cos(m_a t) \vec{B}_{dc}(\mathbf{x})$$

# DMRadio basics: circuit model formalism

At frequencies where wavelength  $\gg$  size of detector (i.e. lumped element regime)

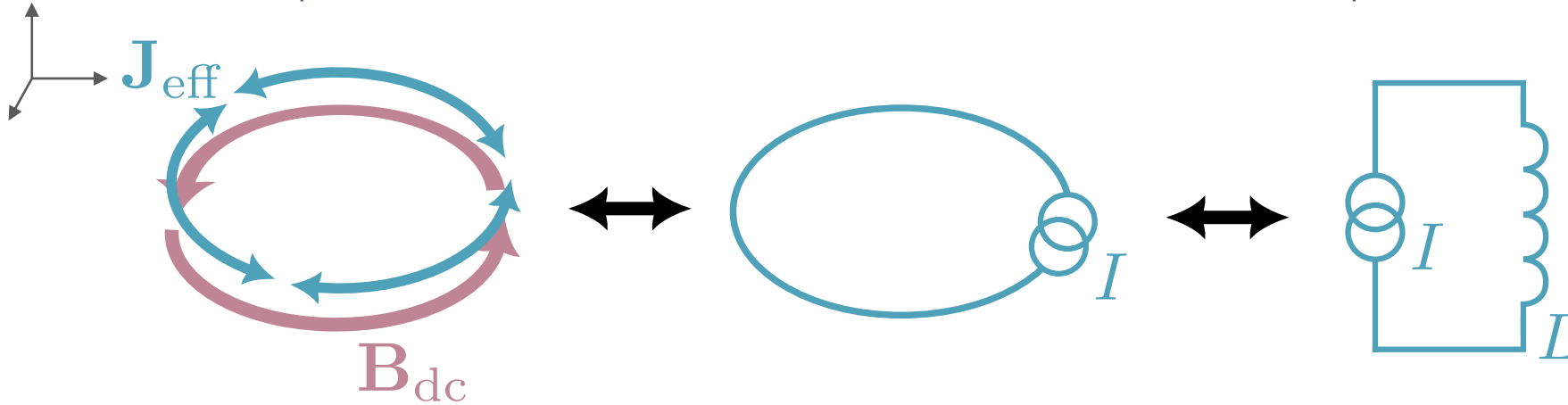

Create **dc magnetic field**, e.g. toroidal magnet

**Axion current** oscillates along magnetic field lines

$$\vec{J}_{eff}(\mathbf{x}, t) = g_{a\gamma\gamma} \sqrt{2\rho_{DM}} \cos(m_a t) \vec{B}_{dc}(\mathbf{x})$$

This acts as a current source in series with an inductor

There is no electron current flowing here, just induced fields that resemble

those of an electron current

# DMRadio basics: circuit model formalism

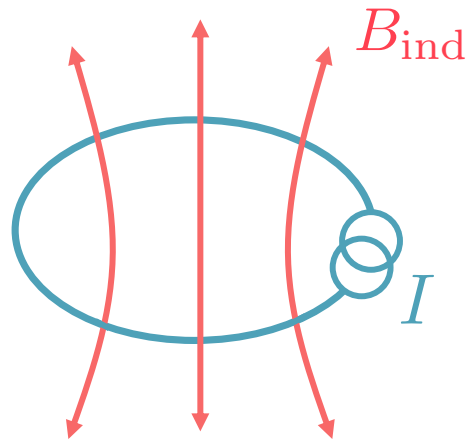

Axion current induces **ac magnetic field**

# DMRadio basics: circuit model formalism

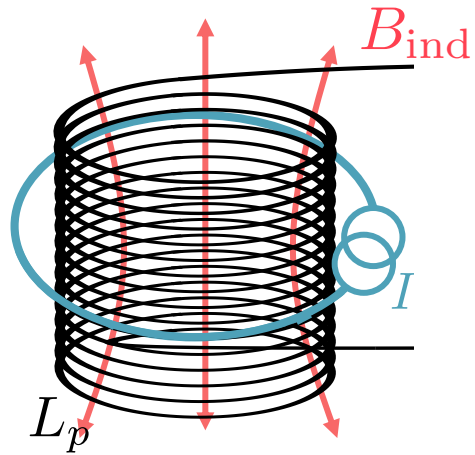

Pick up ac magnetic field using lumped inductor

# DMRadio basics: circuit model formalism

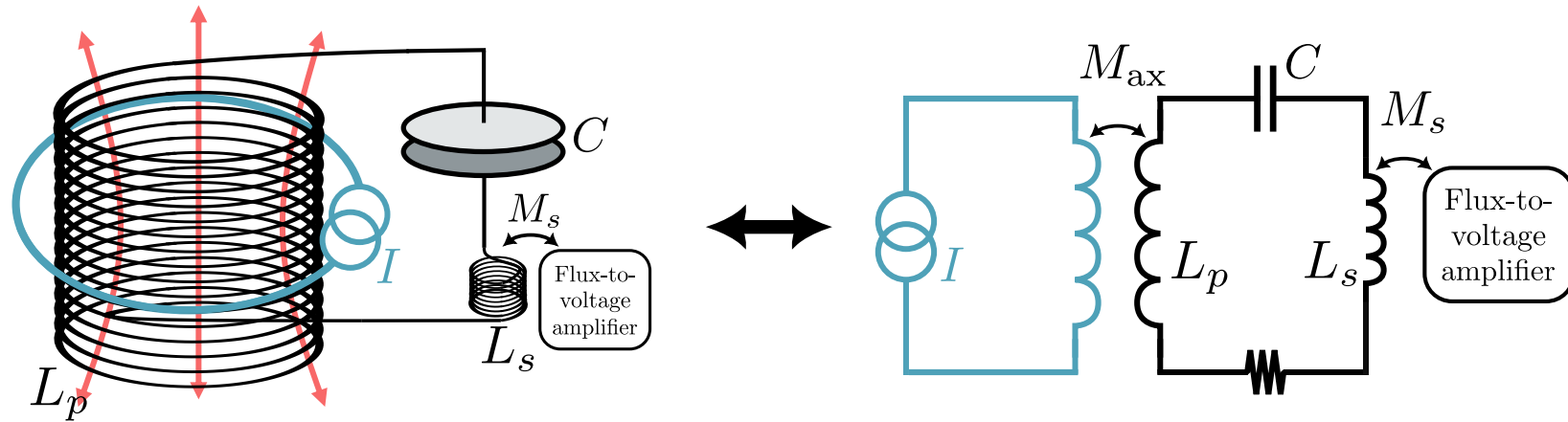

Pick up ac magnetic field using lumped inductor

Turn into LC oscillator by including capacitor in series. Current flowing in circuit enhanced by quality factor

Pick up induced current using flux-to-voltage amplifier, e.g. dc SQUID,

radiofrequency quantum upconverter

# Current state of axion searches

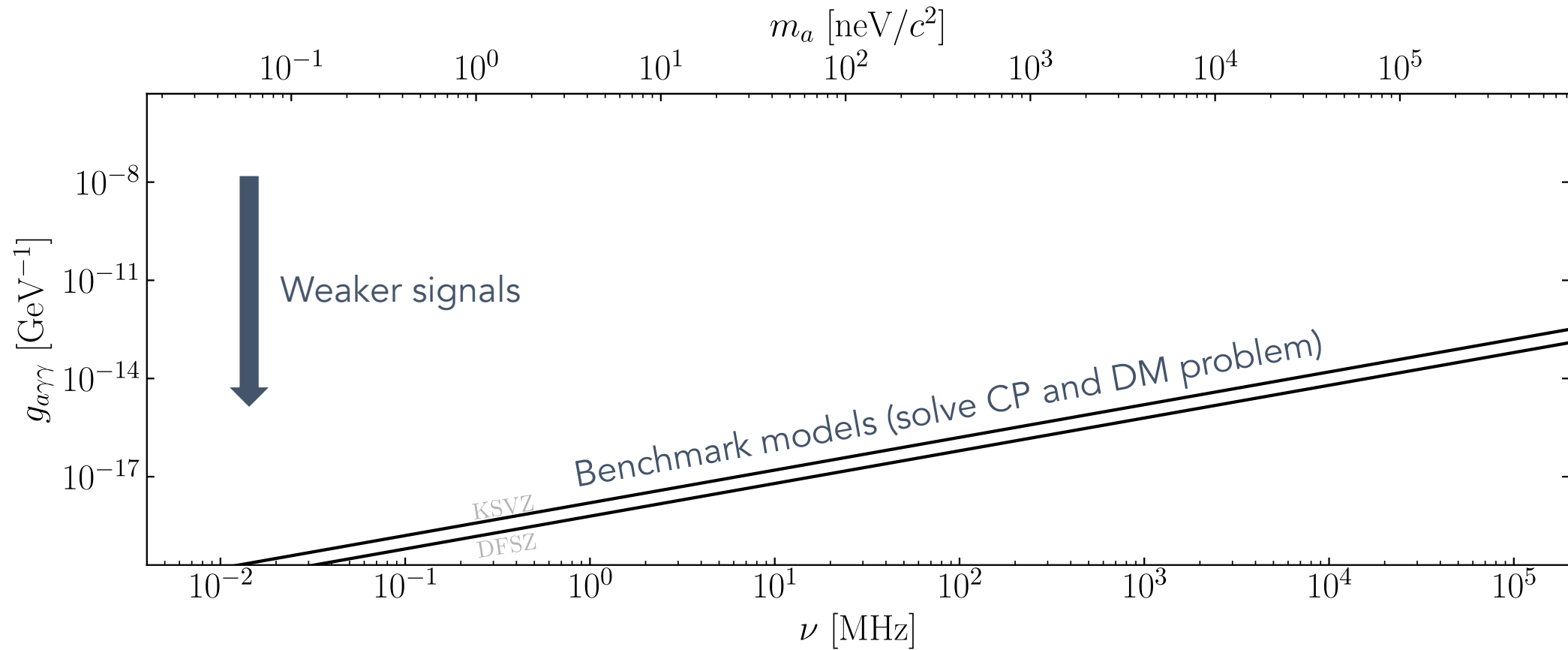

# Current state of axion searches



Direct detection does not rely  
on axions being the dark matter

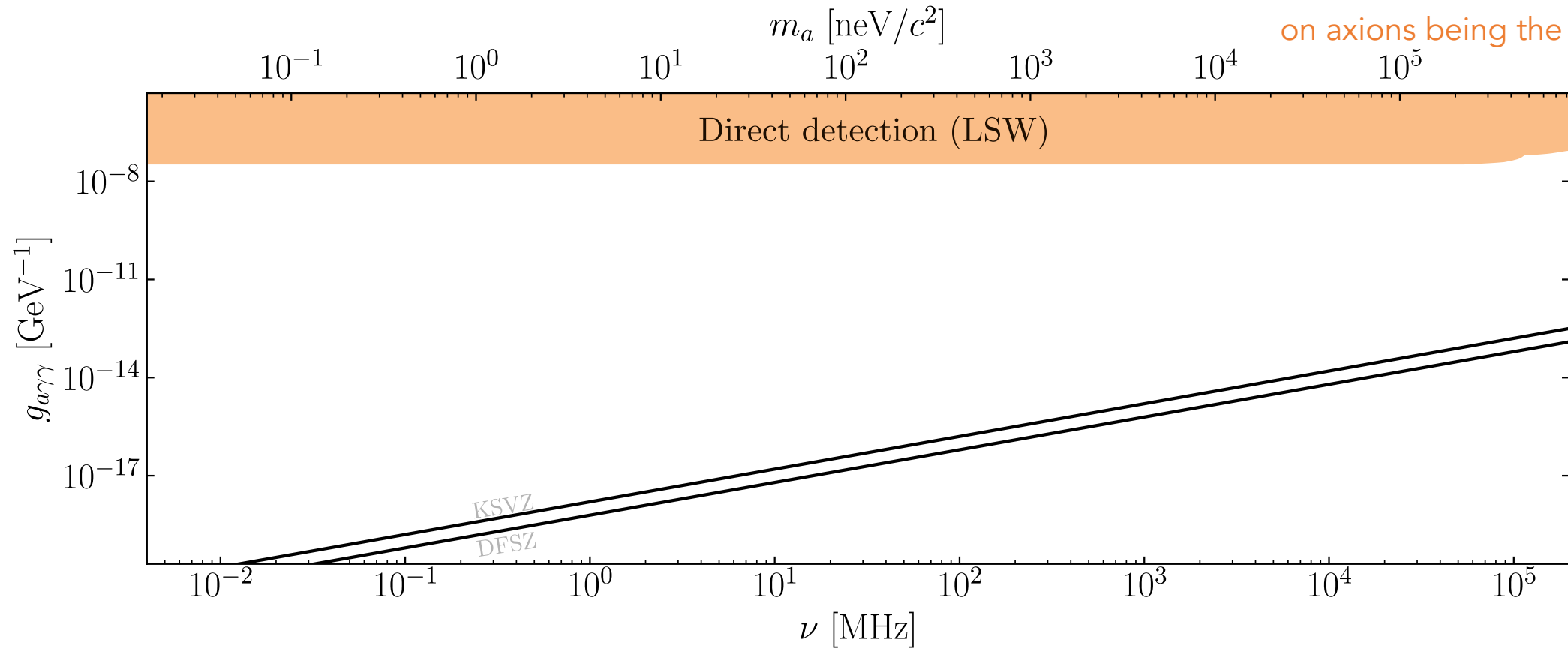

# Current state of axion searches

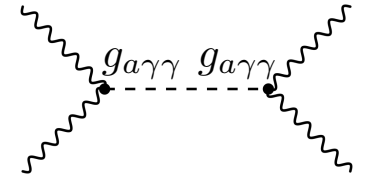

Direct detection does not rely on axions being the dark matter

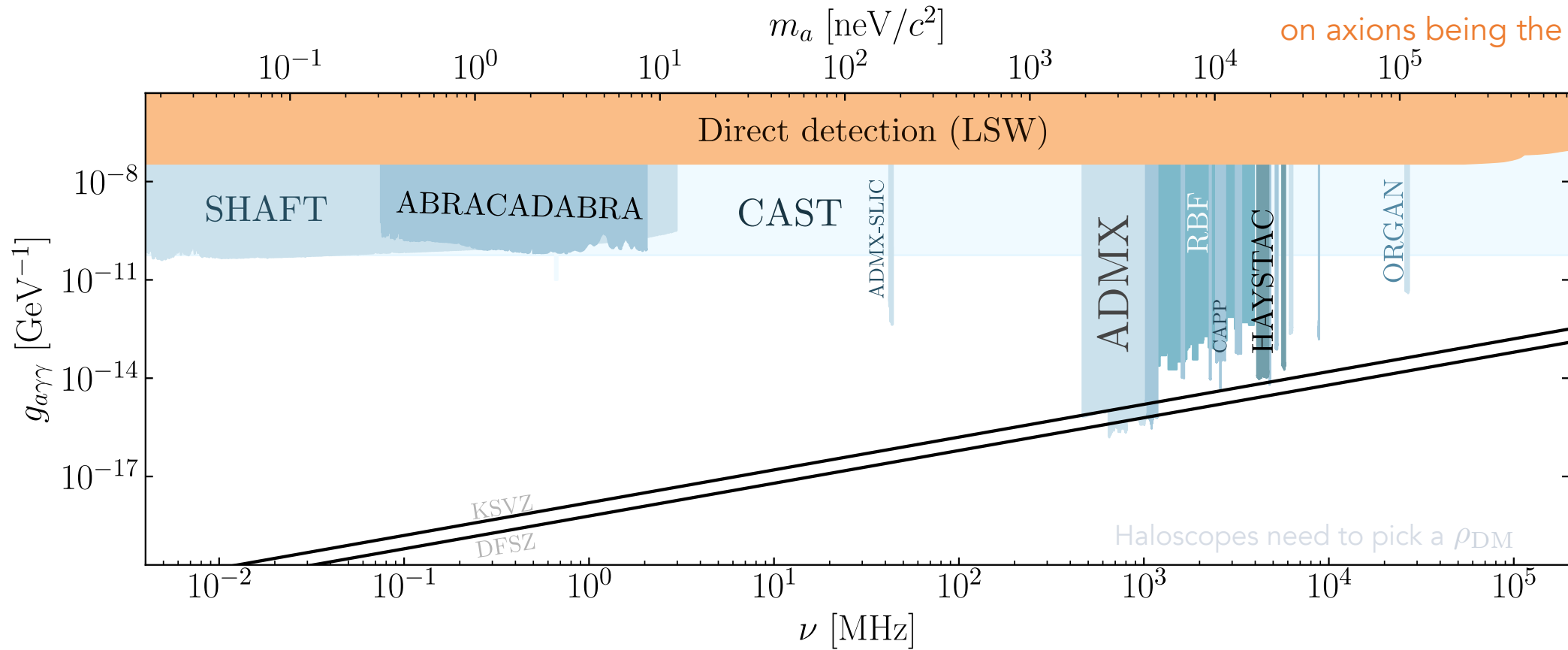

# Current state of axion searches

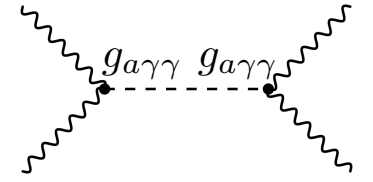

Direct detection does not rely on axions being the dark matter

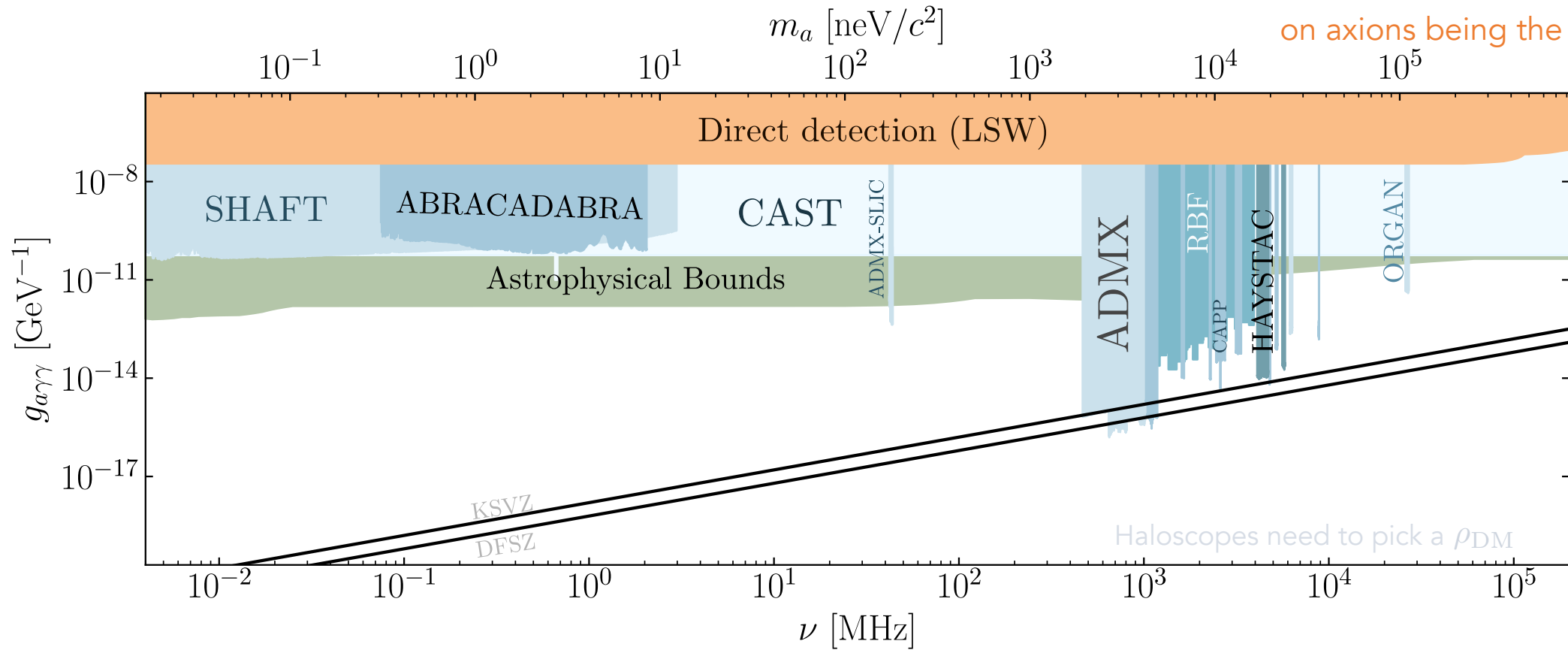

# DMRadio goals

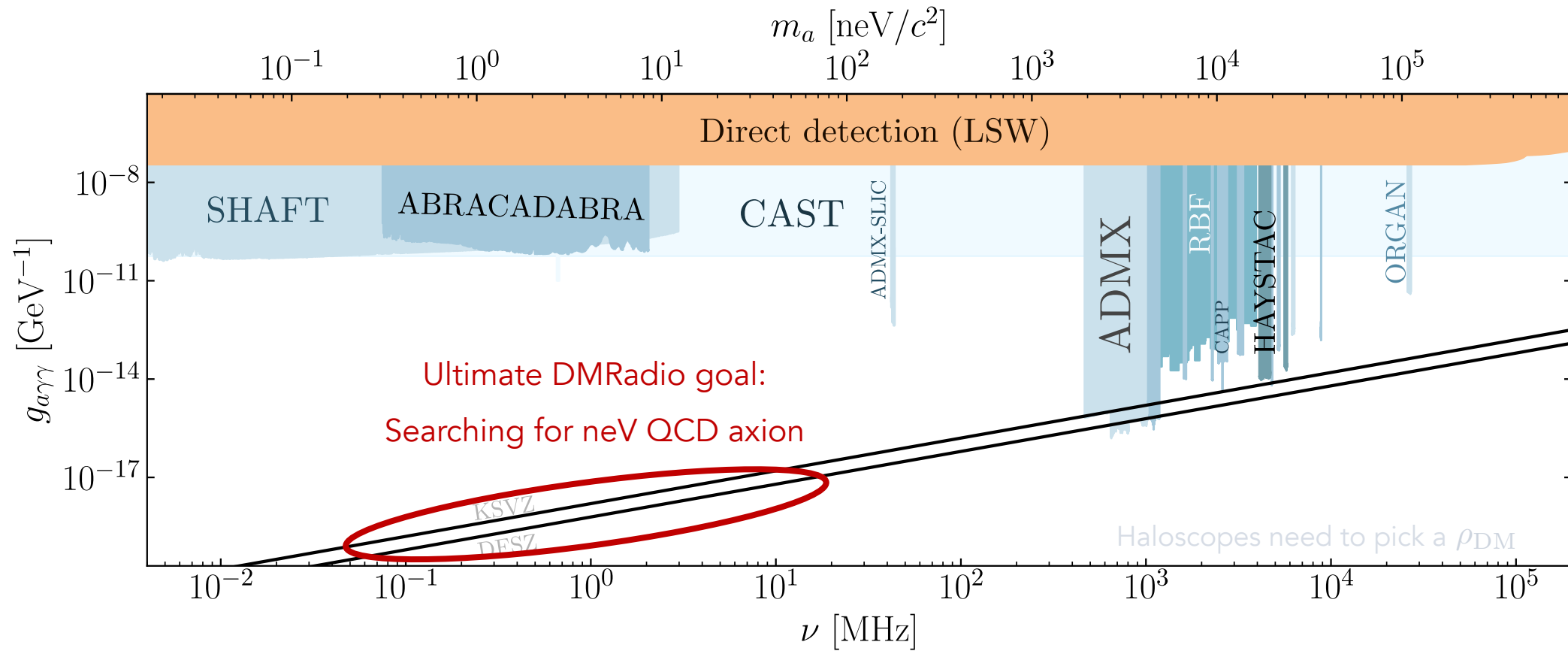

# DMRadio suite of experiments

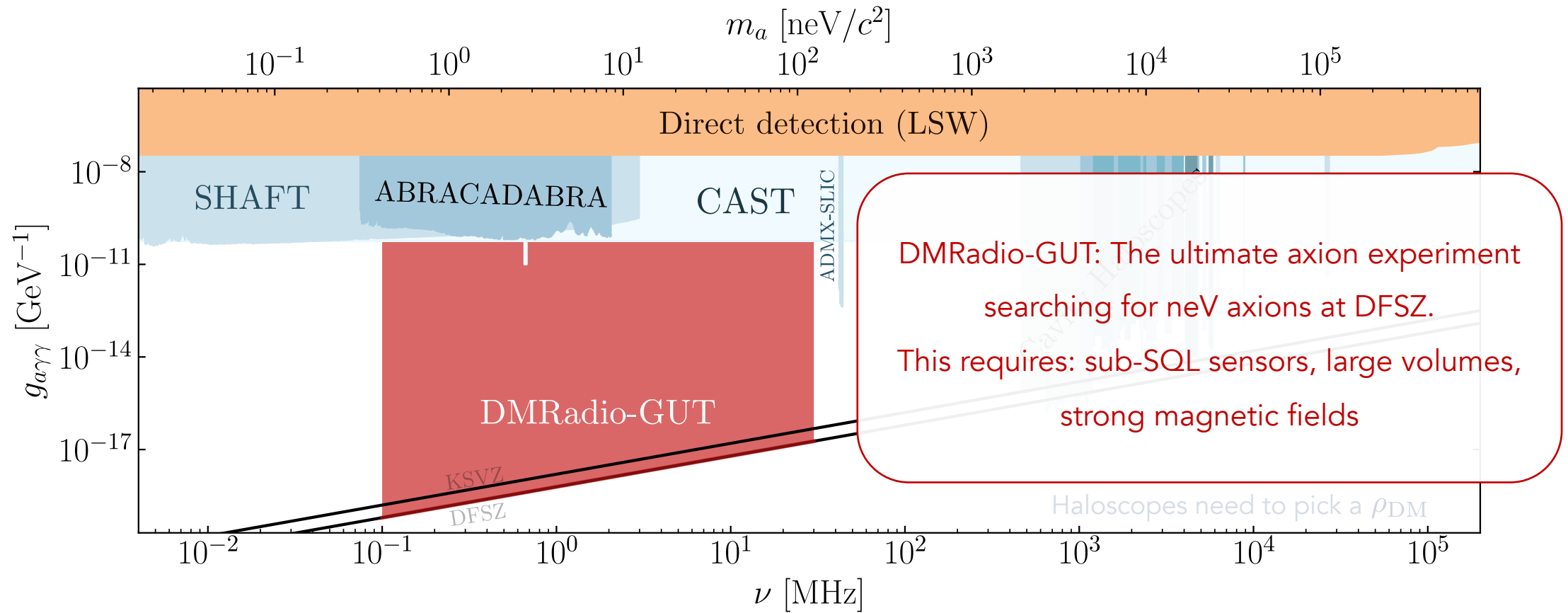

# DMRadio suite of experiments

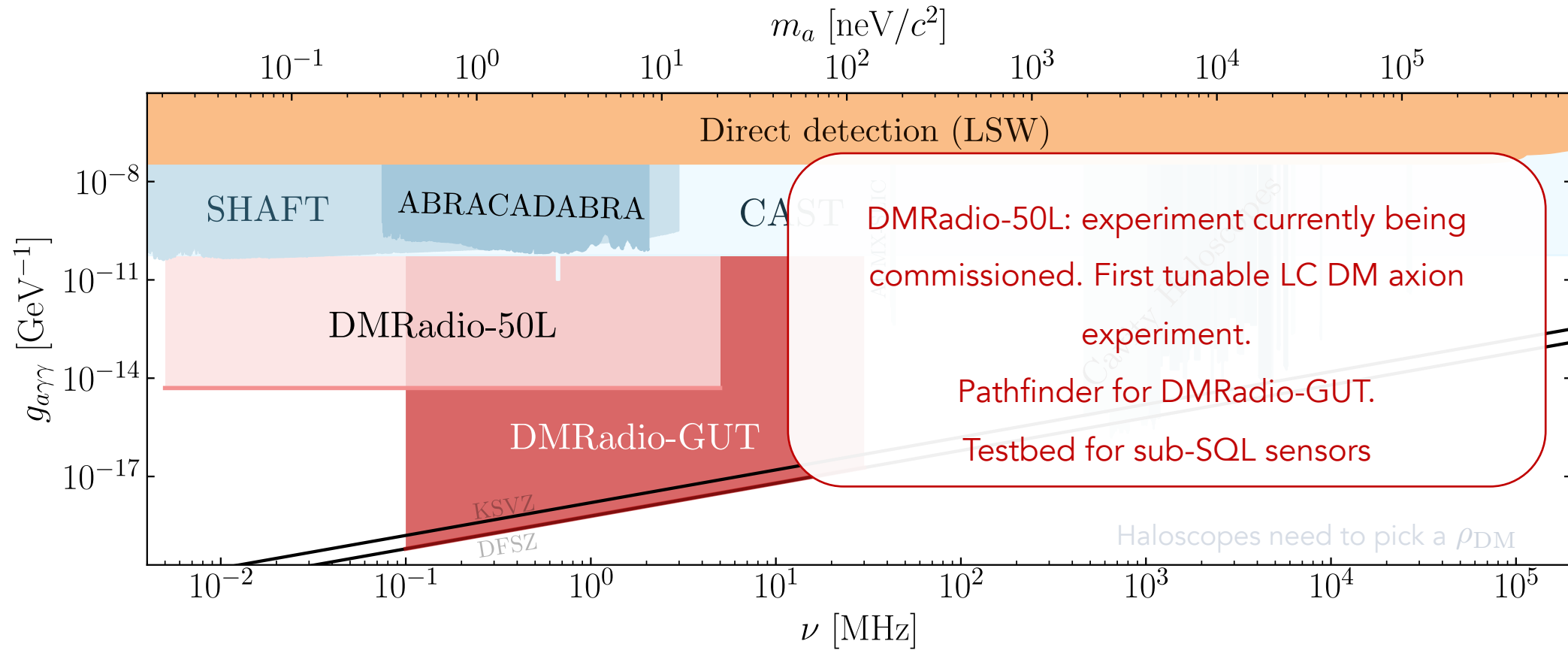

DMRadio-GUT: ultimate future  
 axion experiment

# DMRadio suite of experiments

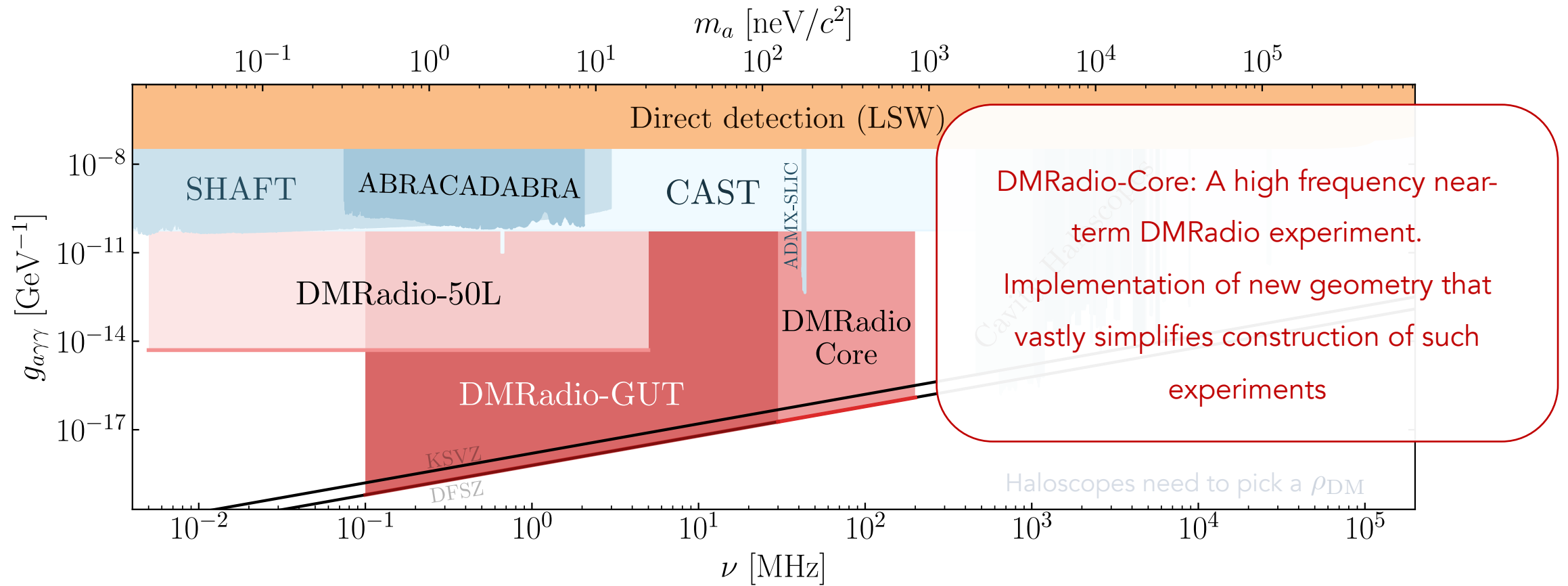

DMRadio-GUT: ultimate future axion experiment

DMRadio-50L: currently commissioning. Pathfinder for DMRadio-GUT

# Thermal occupation and quantum noise

$$h\nu = k_B T$$

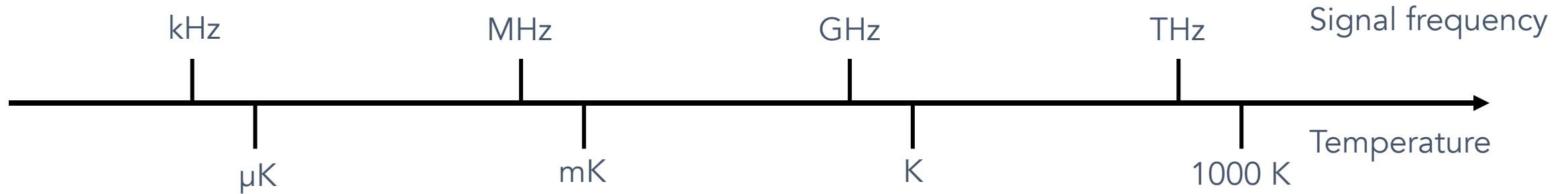

# Thermal occupation and quantum noise

$$h\nu = k_B T$$

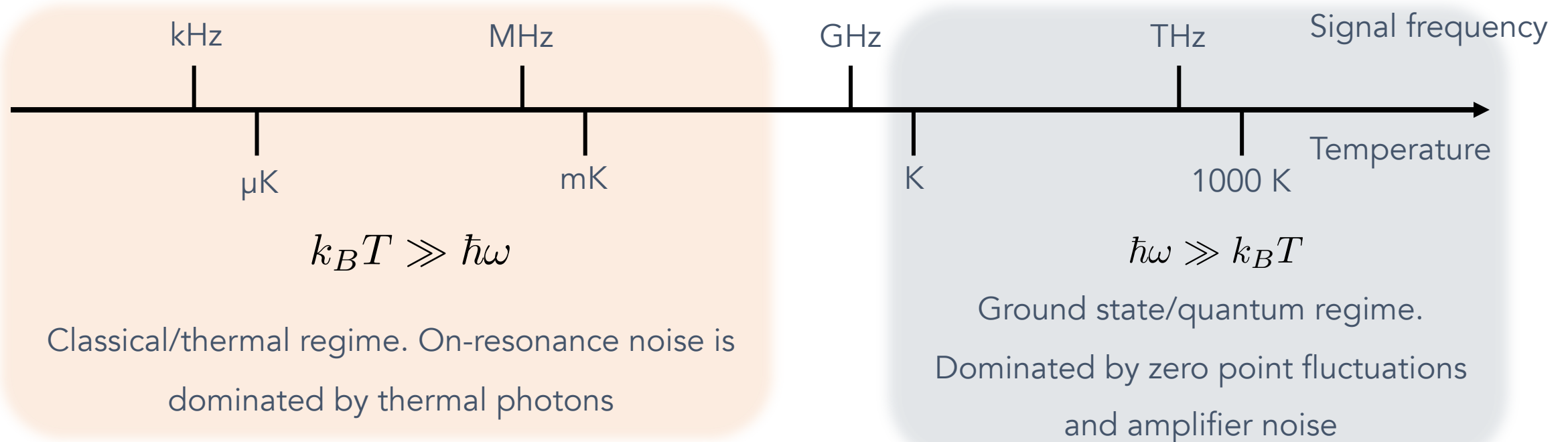

*Operating at 100 mK*

# Thermal occupation and quantum noise

$$h\nu = k_B T$$

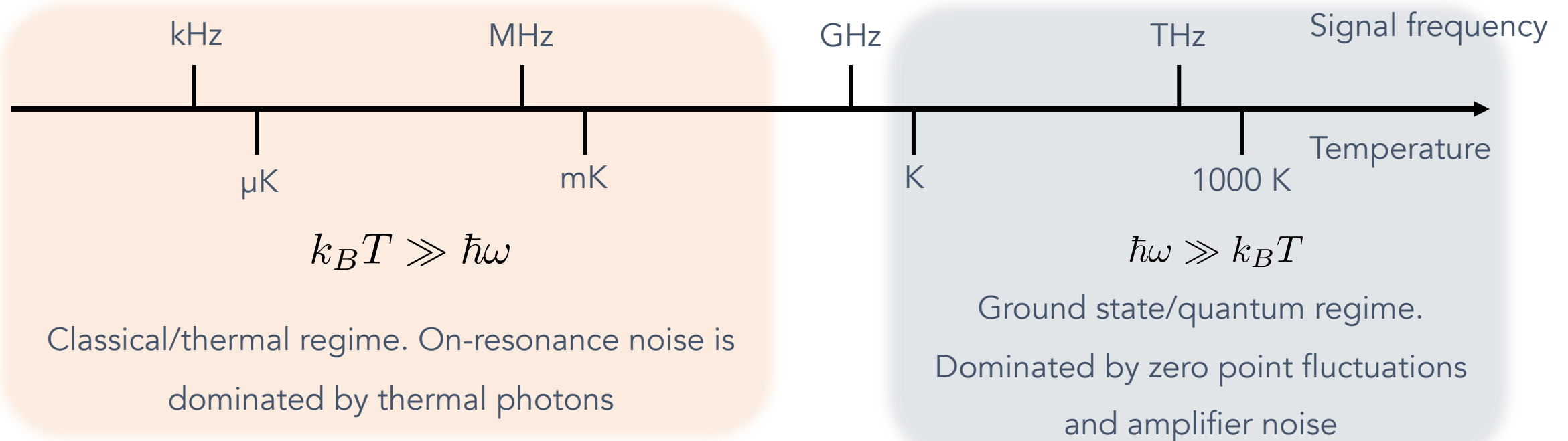

Operating at 100 mK

What role does quantum enhancement play in the thermal limit?

# DMRadio: source and noise terms

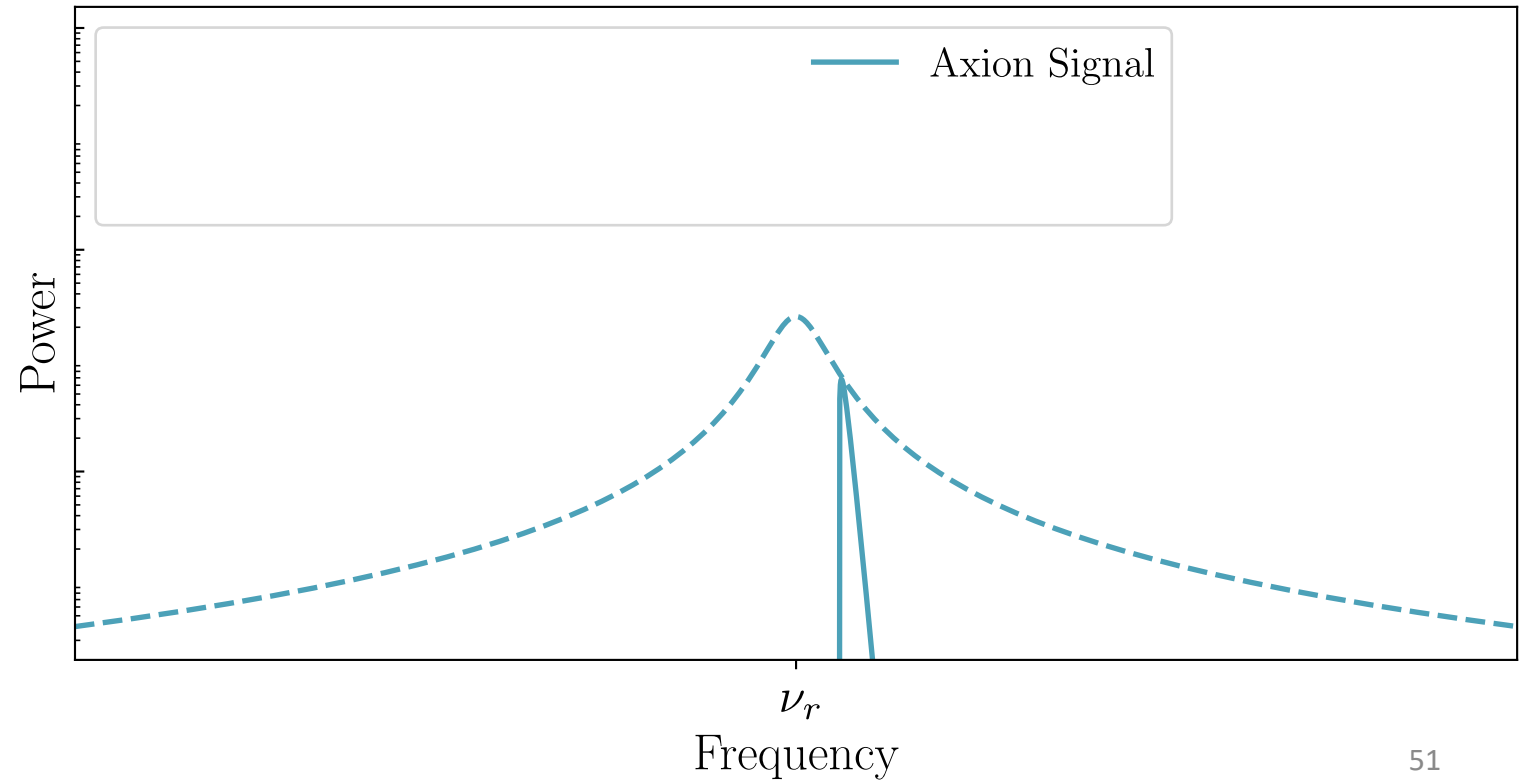
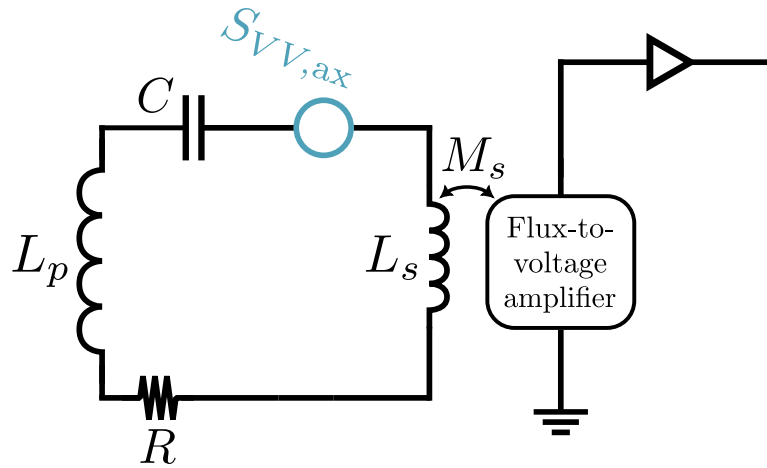

# DMRadio: source and noise terms

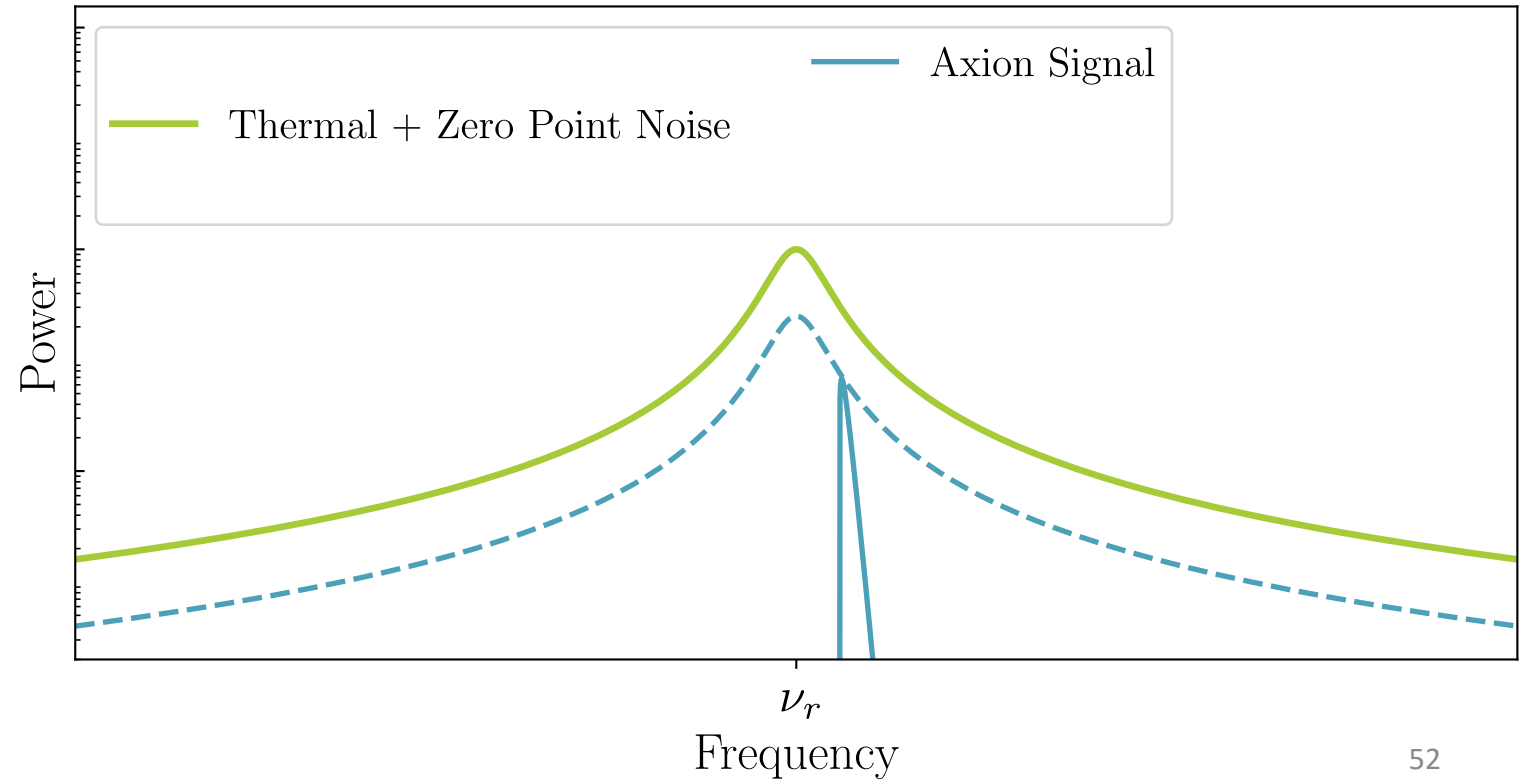
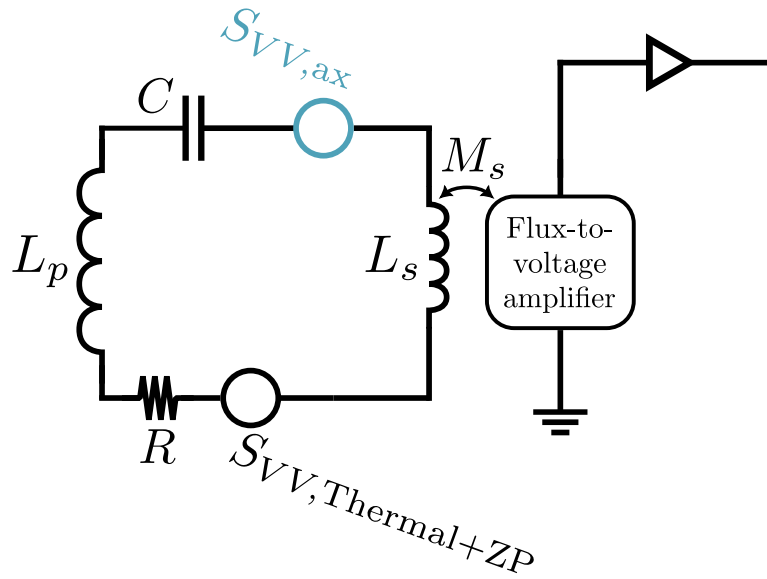

# DMRadio: source and noise terms

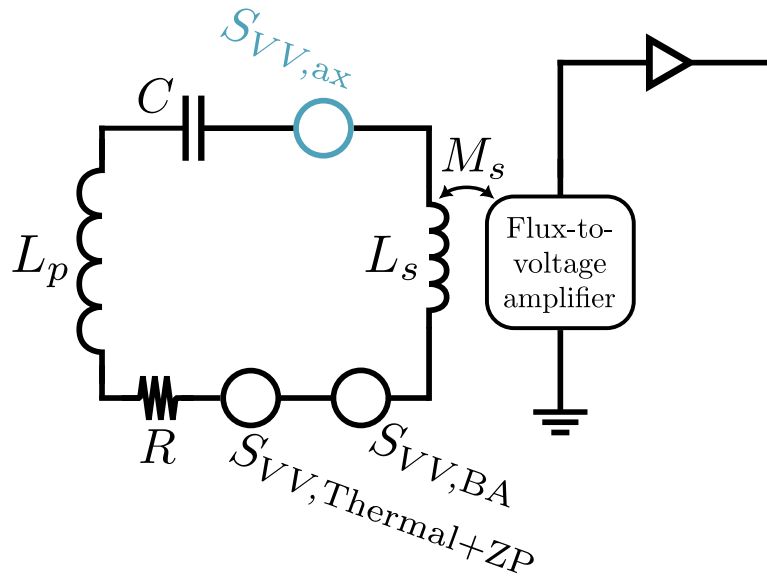

In this scenario, axion maintains constant SNR  
arbitrarily far detuned from resonance

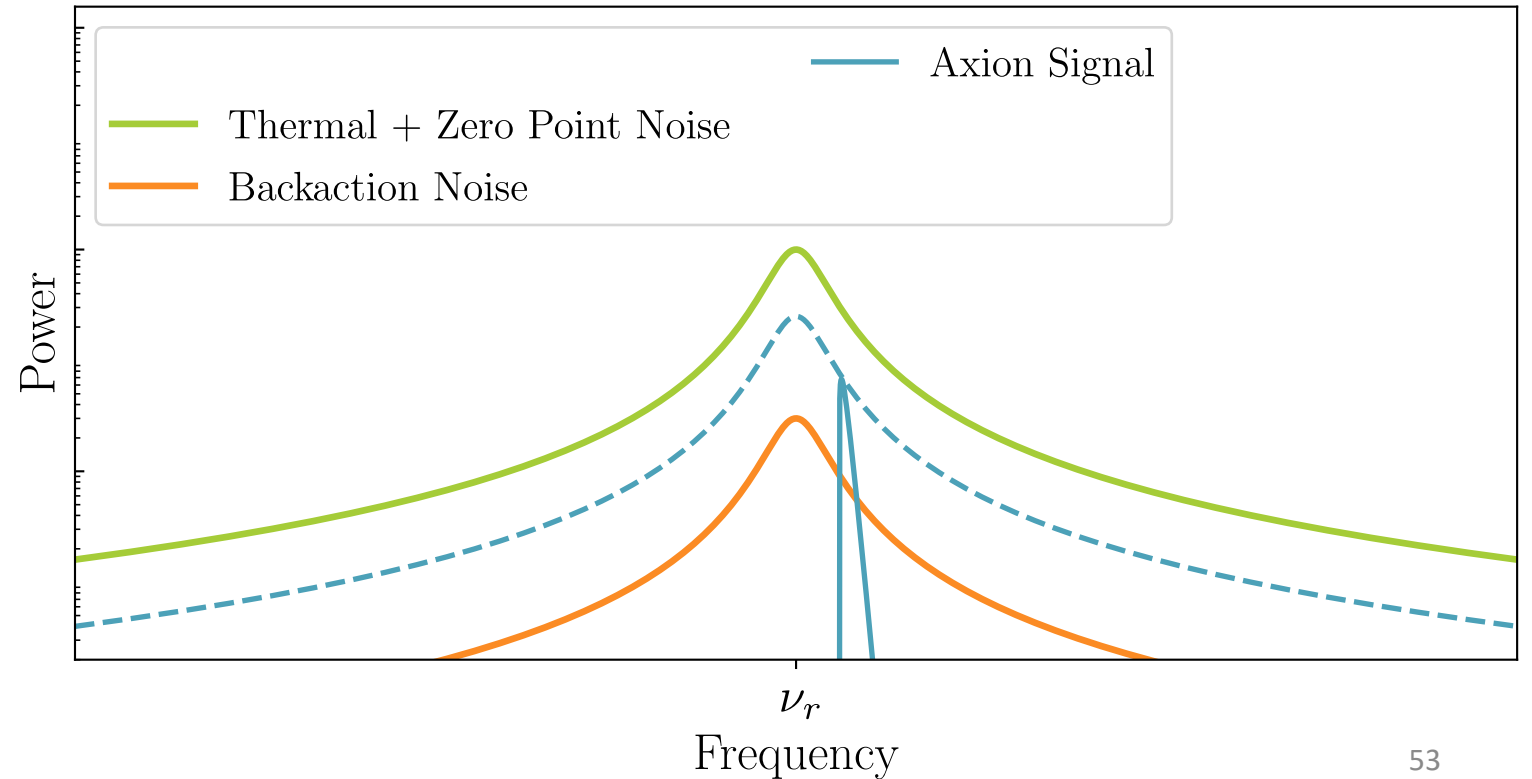

# DMRadio: source and noise terms

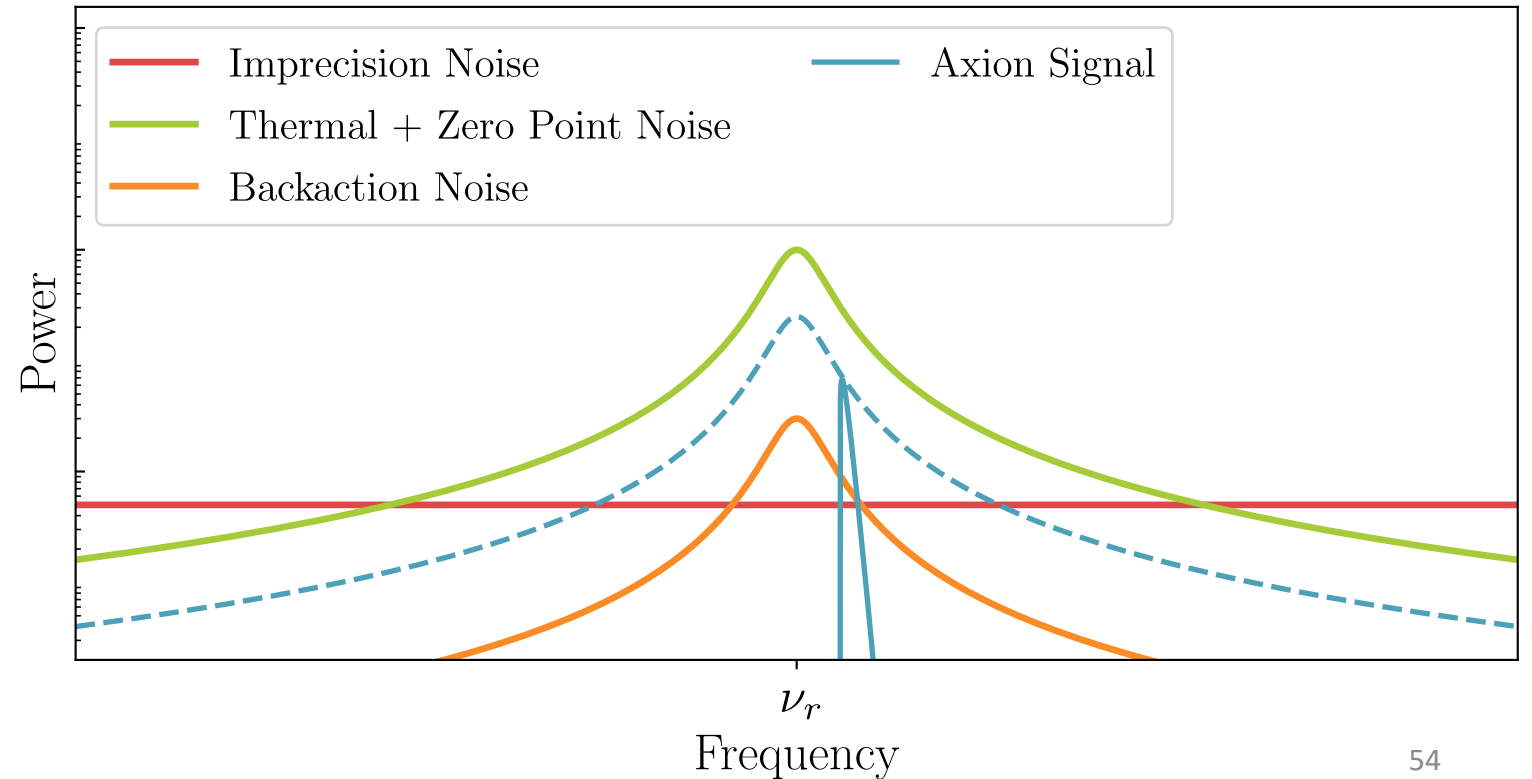
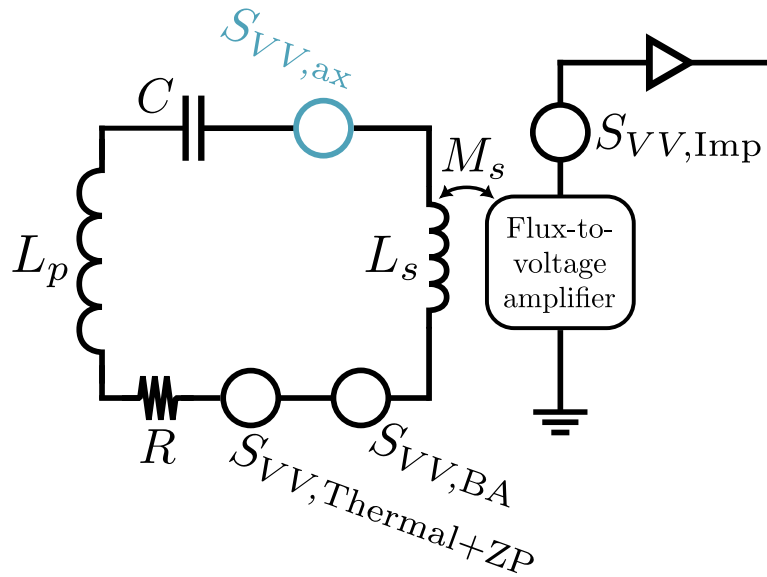

# DMRadio: source and noise terms

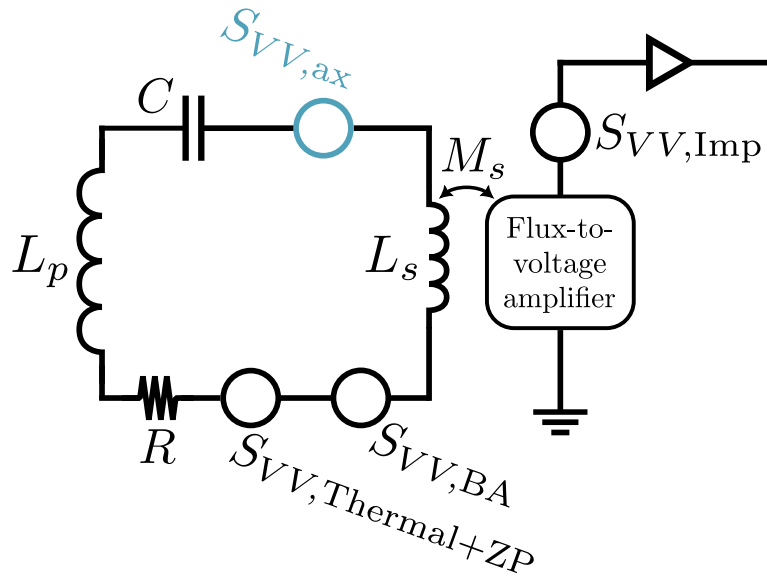

Sensitivity bandwidth  
 Beyond this bandwidth, SNR drops  
 This sets scan rate of experiment

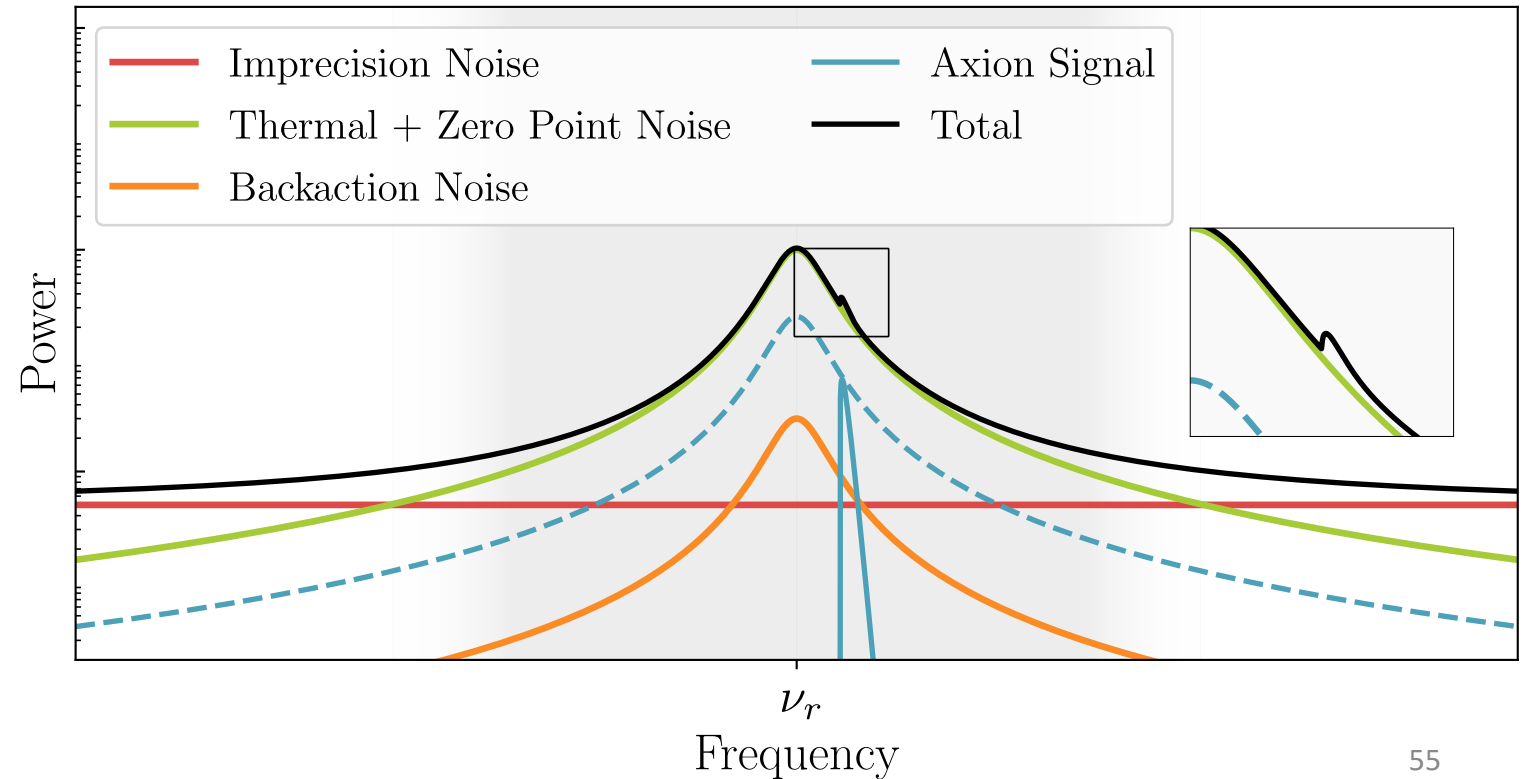

# DMRadio: source and noise terms

Resonator is in thermal limit and on-resonance noise is dominated by thermal photons

BUT

Bandwidth over which the experiment is sensitive is determined by amplifier contributions

Sensitivity bandwidth  
Beyond this bandwidth, SNR drops  
This sets scan rate of experiment

This is much larger than resonator linewidth

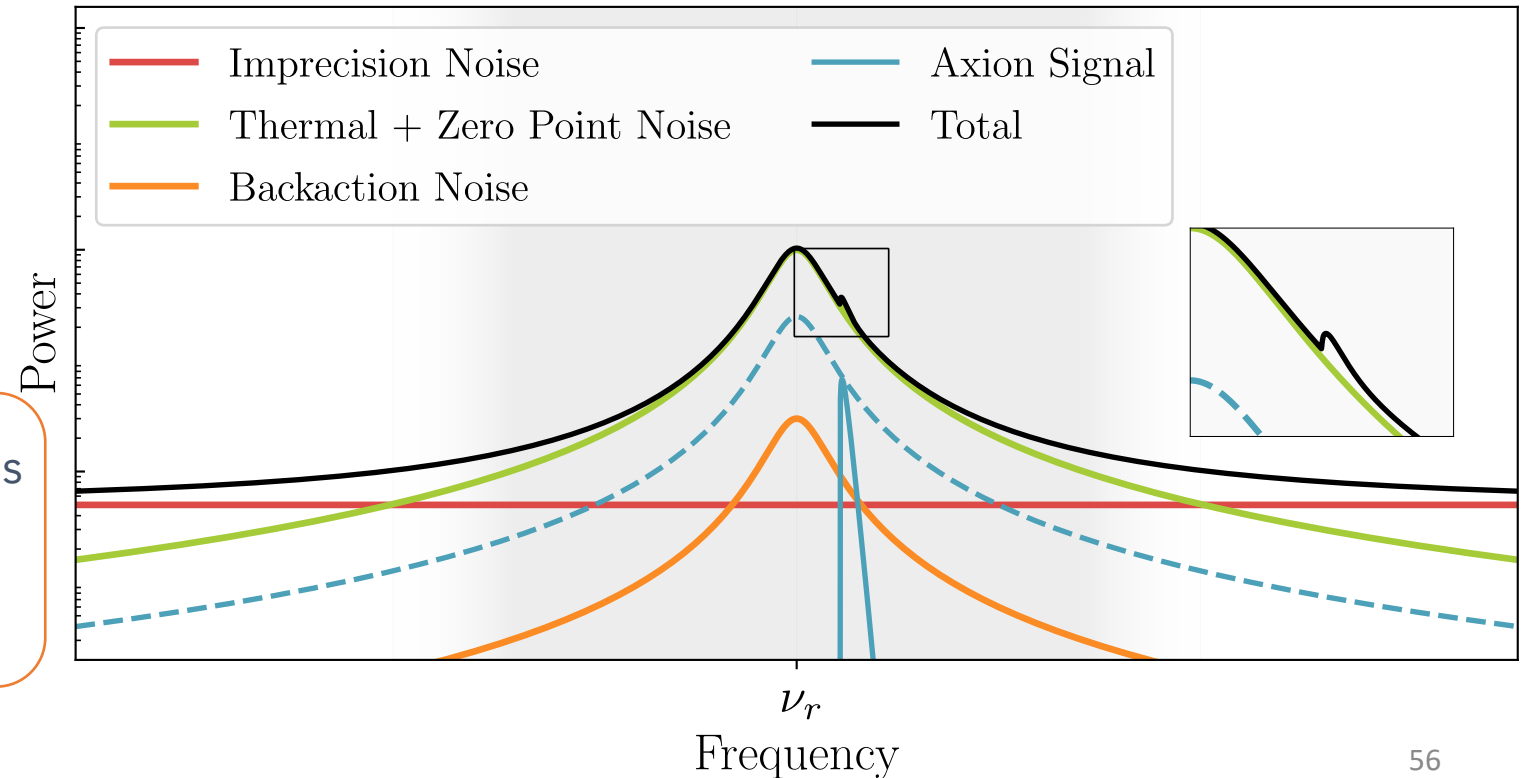

# Optimizing the sensitivity bandwidth

What if we adjust coupling between resonator and amplifier?

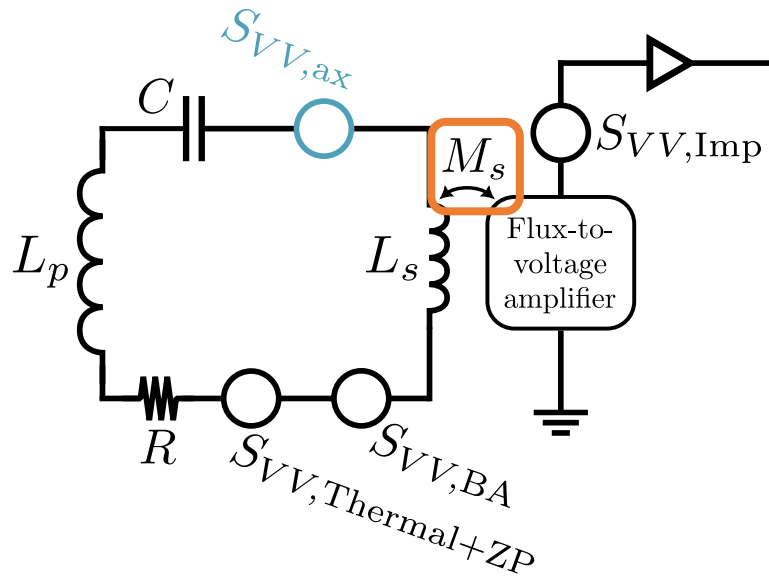

Weaker coupling:

Decreased backaction

Increased imprecision

Stronger coupling:

Increased backaction

Decreased imprecision

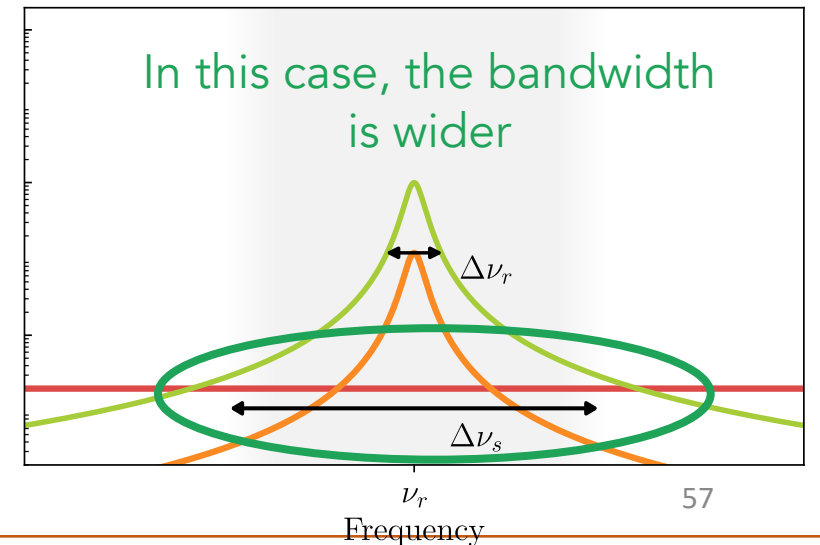
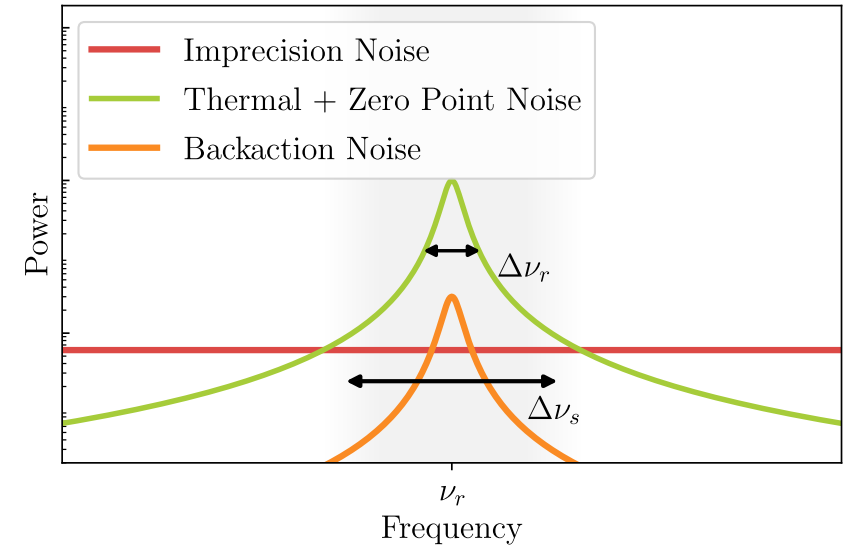

# Standard Quantum Limit

An amplifier operating at the Standard Quantum Limit obeys

$$\sqrt{S_{VV,BA} S_{II,Imp}} \geq \hbar\omega/2$$

Assuming no correlations

What techniques can we employ to evade it?

Backaction evasion

Widens sensitivity bandwidth, does not improve on-resonance SNR

# Backaction evasion

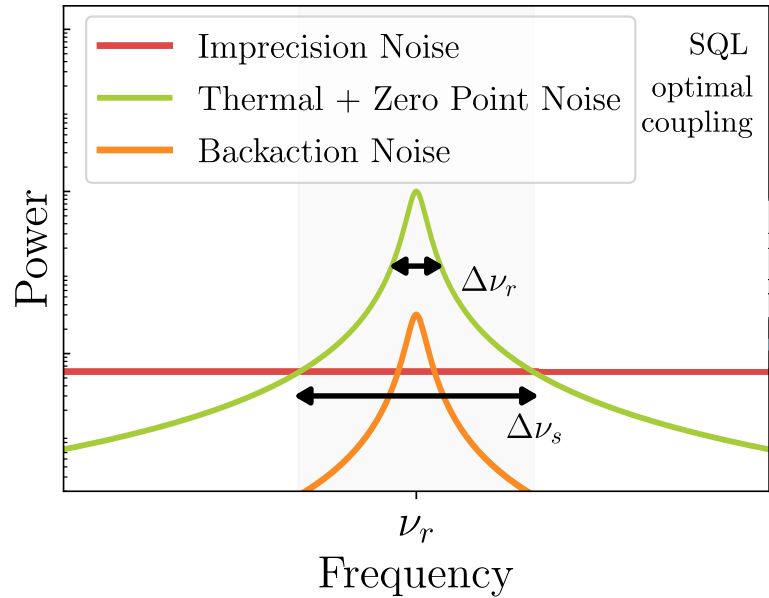

Assume optimized bandwidth  
for SQL limited:

$$\sqrt{S_{VV,BA} S_{II,Imp}} = \hbar\omega/2$$

# Backaction evasion

Only quadrature of interest is shown and being measured.  
Unmeasured quadrature has worse performance (obeying Heisenberg)

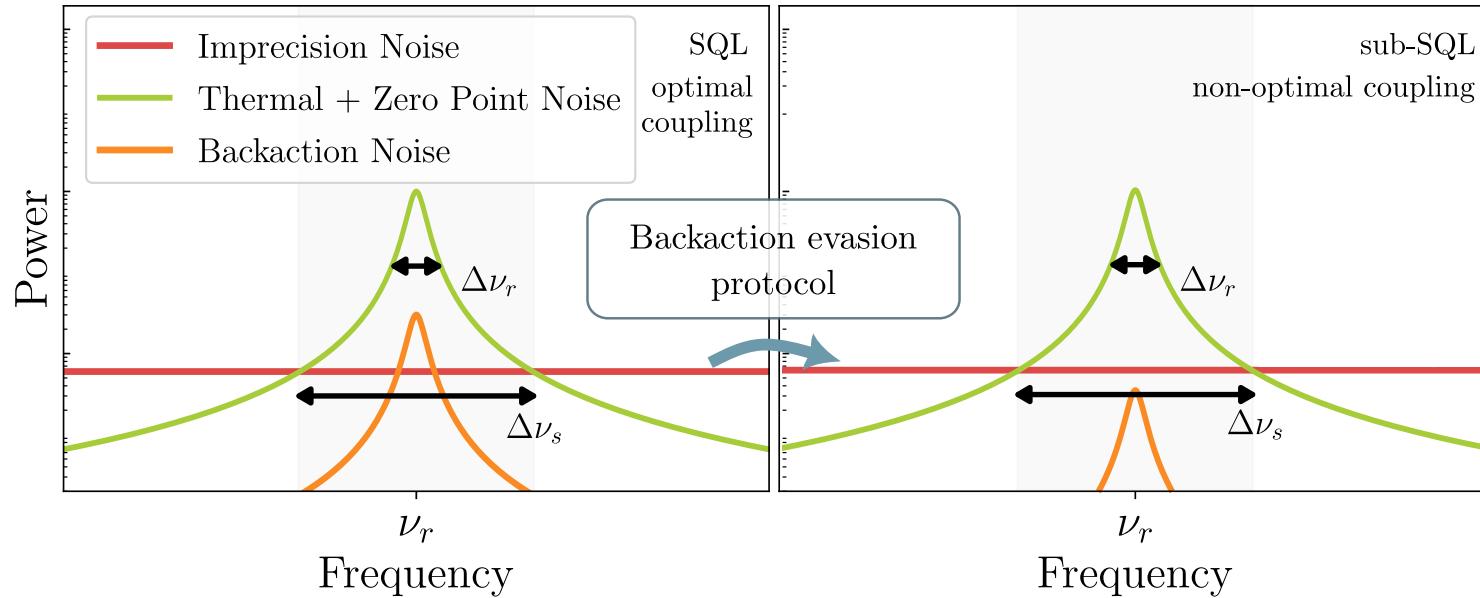

Assume optimized bandwidth for SQL limited:

$$\sqrt{S_{VV,BA} S_{II,Imp}} = \hbar\omega/2$$

Sub-SQL operation:

$$\sqrt{S_{VV,BA} S_{II,Imp}} < \hbar\omega/2$$

# Backaction evasion

Only quadrature of interest is shown and being measured.  
Unmeasured quadrature has worse performance (obeying Heisenberg)

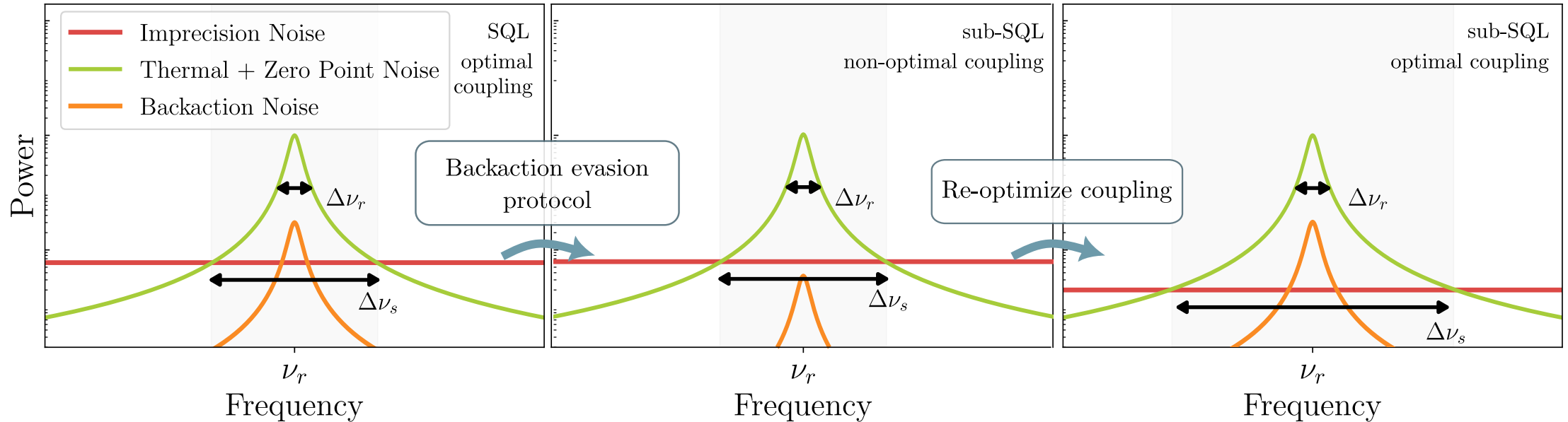

Assume optimized bandwidth for SQL limited:

$$\sqrt{S_{VV,BA} S_{II,Imp}} = \hbar\omega/2$$

Sub-SQL operation:

$$\sqrt{S_{VV,BA} S_{II,Imp}} < \hbar\omega/2$$

Sub-SQL operation and enhanced bandwidth

Radiofrequency quantum upconverters (RQUs) enable backaction evasion  
Irwin group at Stanford: *Phys.Rev.Res.* 7 (2025) 1, 013281

# Outline

Strong CP problem

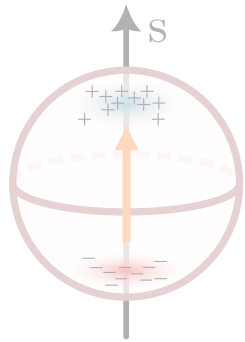

Dark matter



Dark matter axions

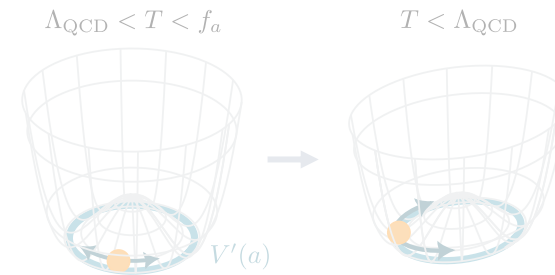

Axion-Standard Model interactions

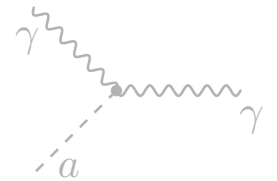

## DMRadio

Ongoing implementation

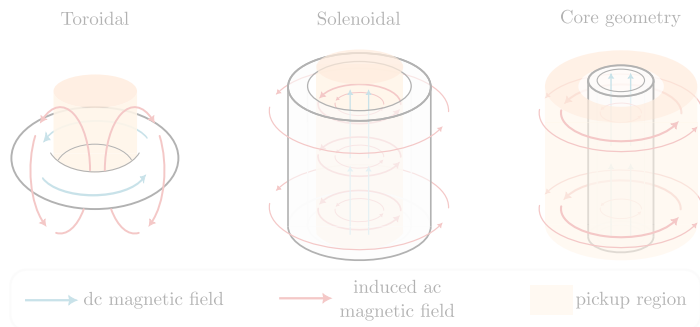

DMRadio-50L

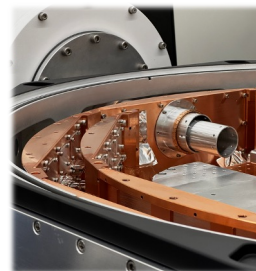

Designs of next generation

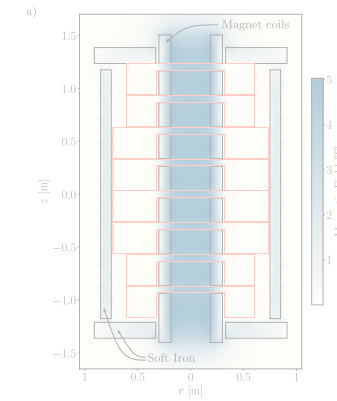

DMRadio-Core, DMRadio-GUT

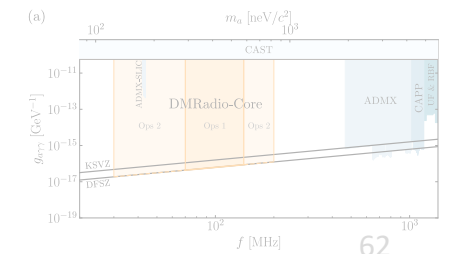

# DMRadio suite of experiments

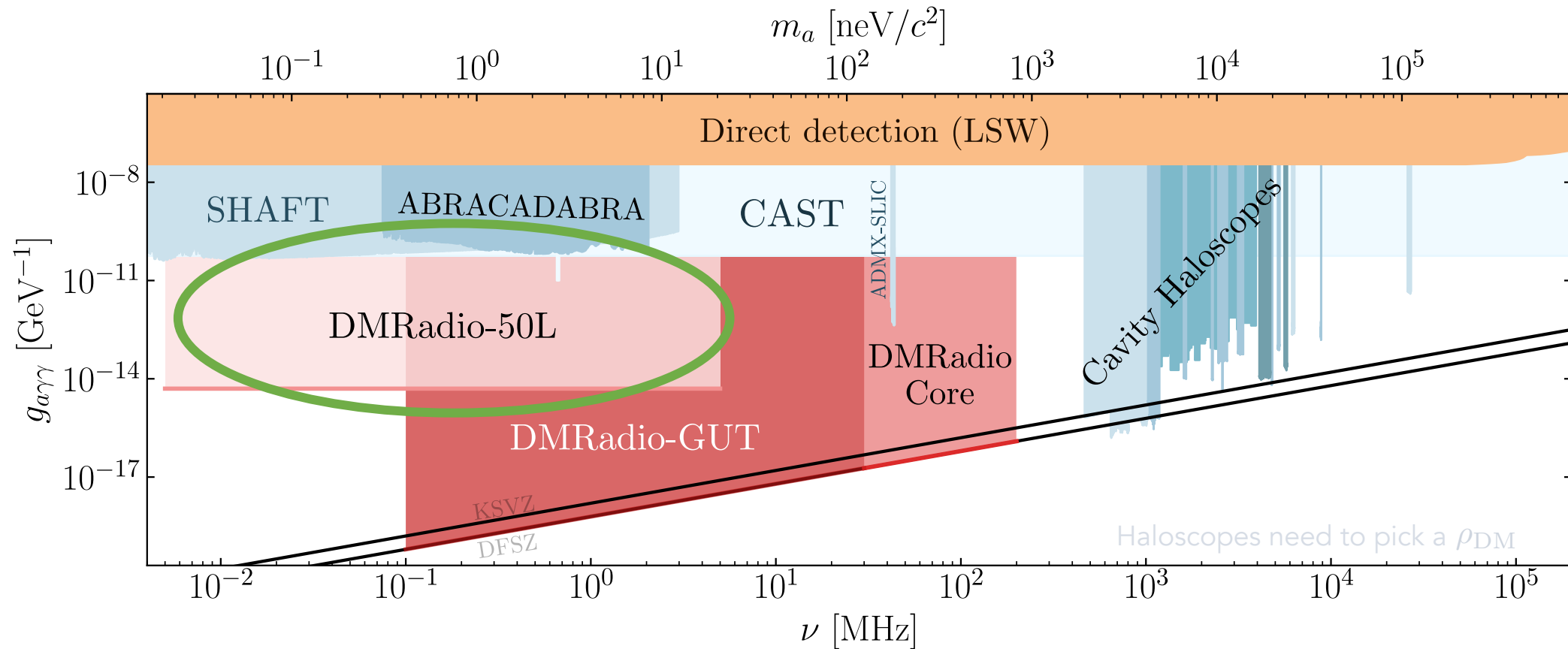

DMRadio-GUT: ultimate future  
axion experiment

DMRadio-50L: currently commissioning.  
Pathfinder for DMRadio-GUT

DMRadio-Core: a high frequency  
experiment using a new geometry

# DMRadio-50L

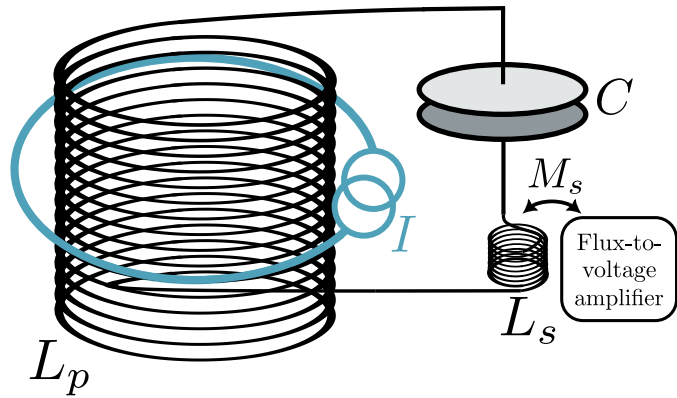

# DMRadio-50L

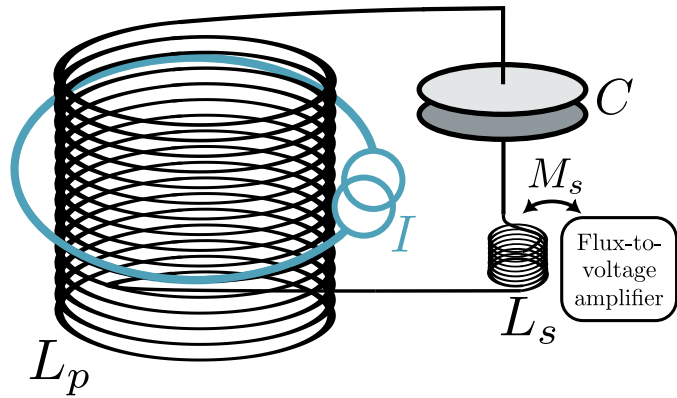

1 T toroidal magnet  
(~50L in volume)

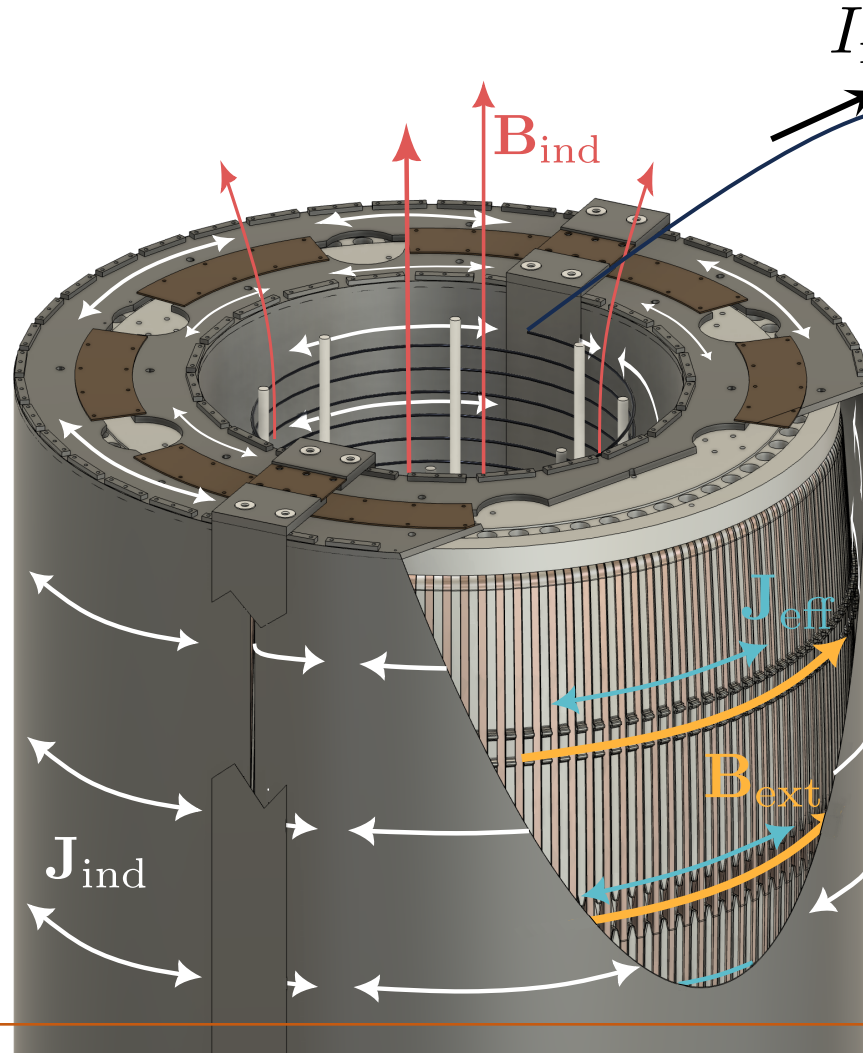

Operating at cryogenic  
temperatures

$I_{meas}$

High Q, kHz resonator

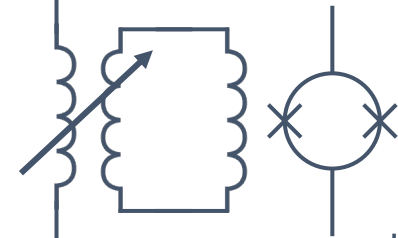

dc SQUIDS  
(and RQUs)

# DMRadio-50L magnet

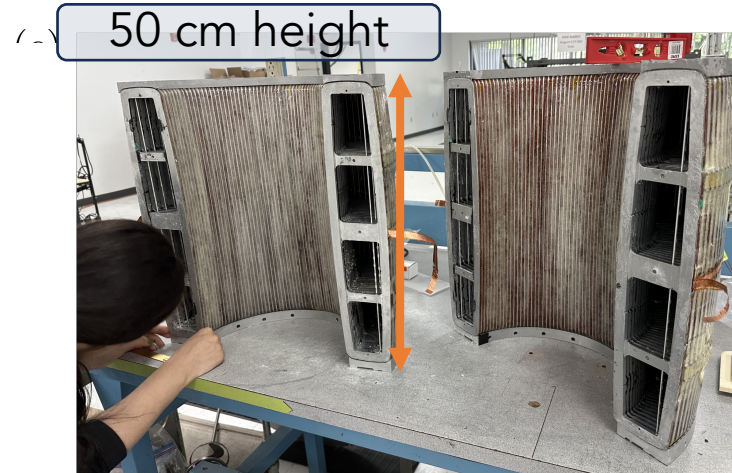

4 K operation

0.9 T field

NbTi superconducting wire

Operating in persistent current mode

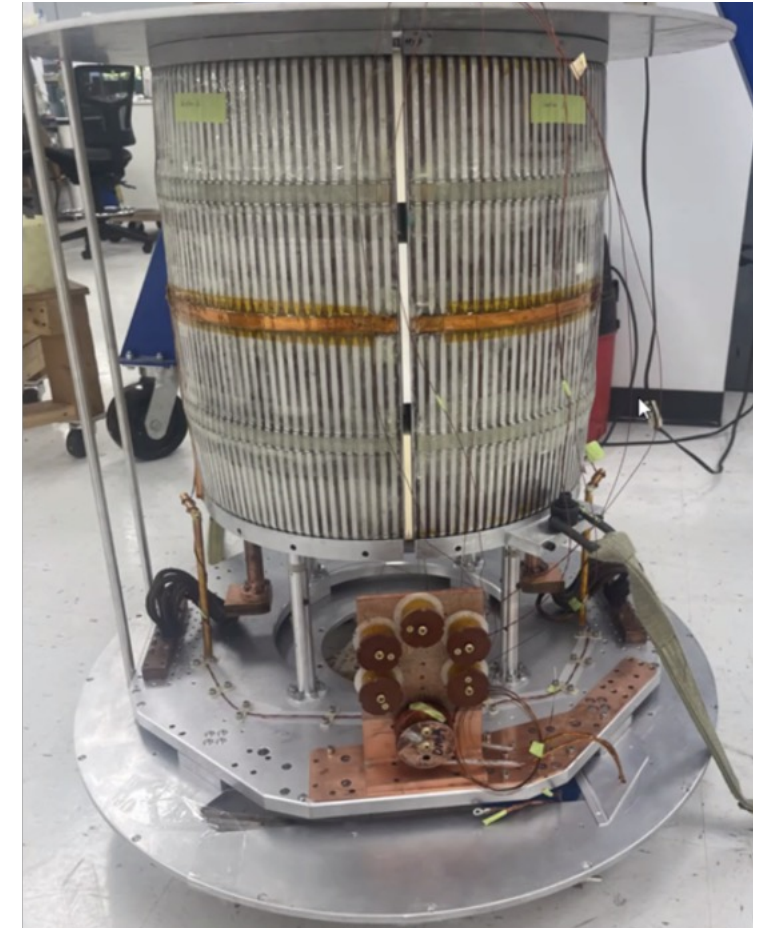
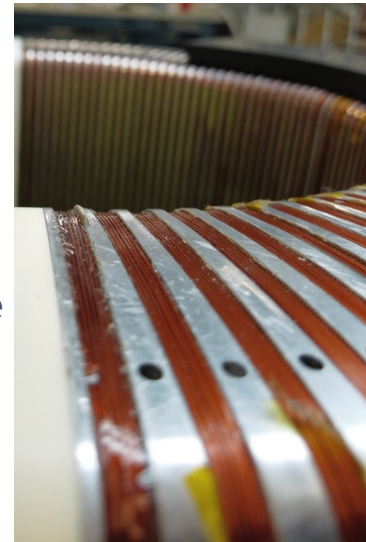

Magnet assembled, wound, and tested by Superconducting Systems Inc.

# DMRadio-50L cryogenics

DR-cryostat thermal connection (*Cold snout*)

Custom 4K cryostat attached to Bluefors Dilution Refrigerator

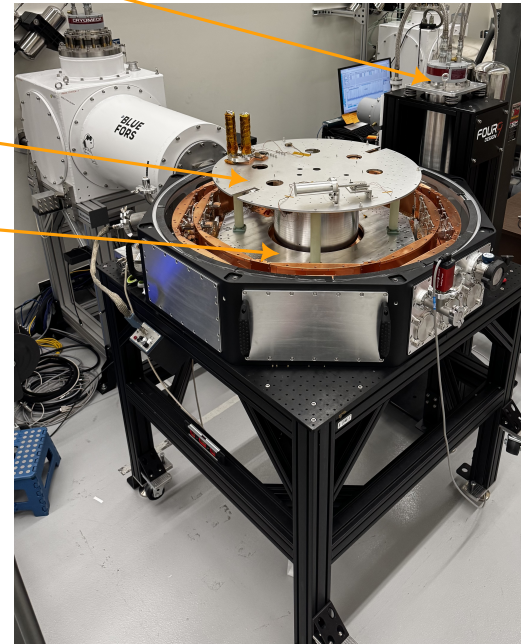
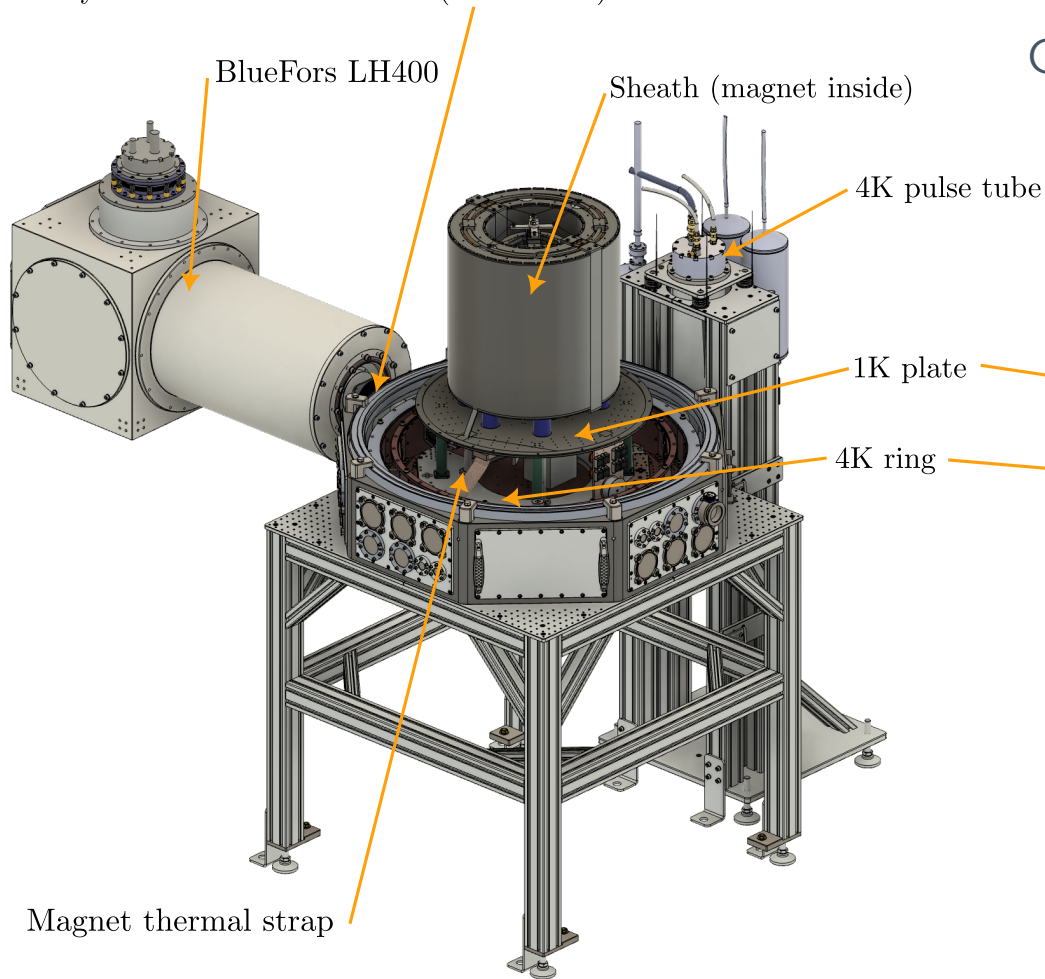

# DMRadio-50L cryogenics

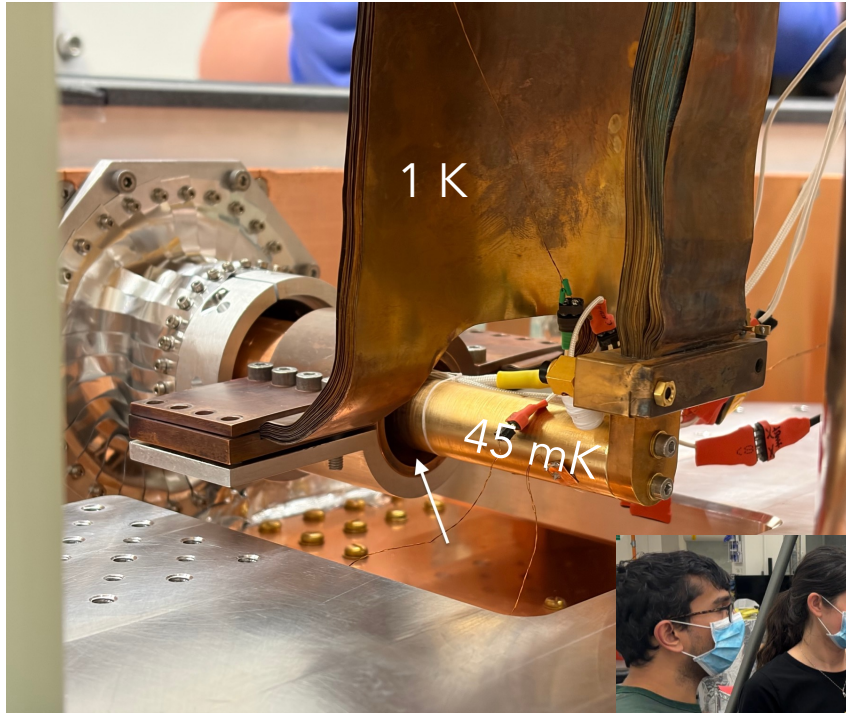

arXiv:2606:xxxxx  
Ankel et al  
*The Cryogenic System of  
DMRadio-50L*

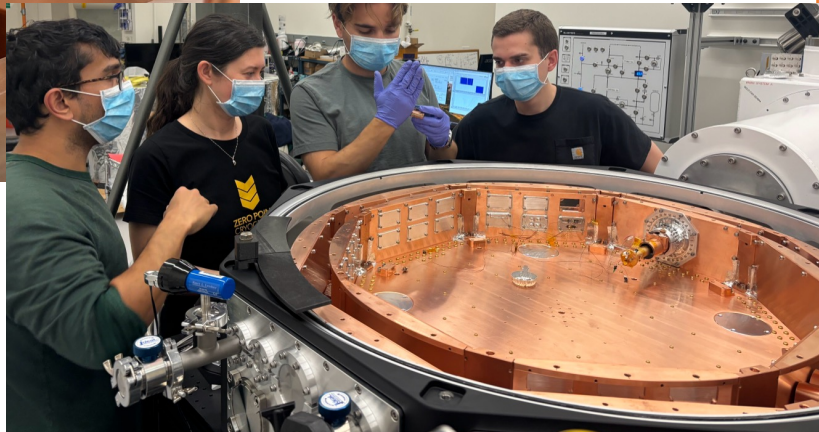

Cryogenics fully commissioned

Base temperature at science payload:  
~45 mK

1 K stage: > 700 mK

4 K stage: >3.3 K

without magnet

Next step: check how magnet and  
resonator load the system

# DMRadio-50L resonator

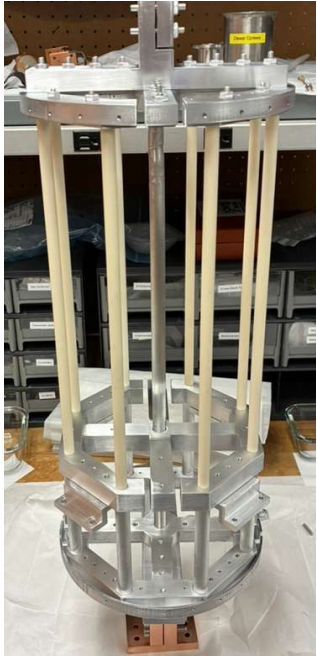

Inductor in center of toroidal magnet that picks up ac magnetic fields attributed to axion

Begin with fixed capacitor

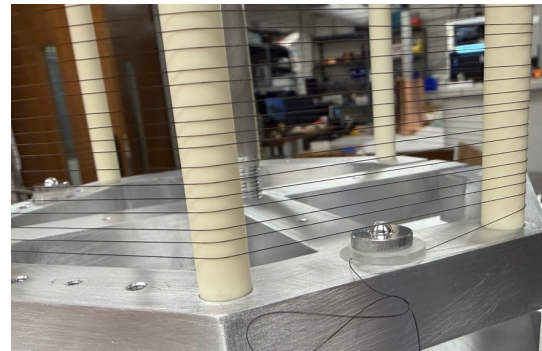

Target Q of  $\sim 1,000,000$

Cryogenic validation underway  
Expected integration by July

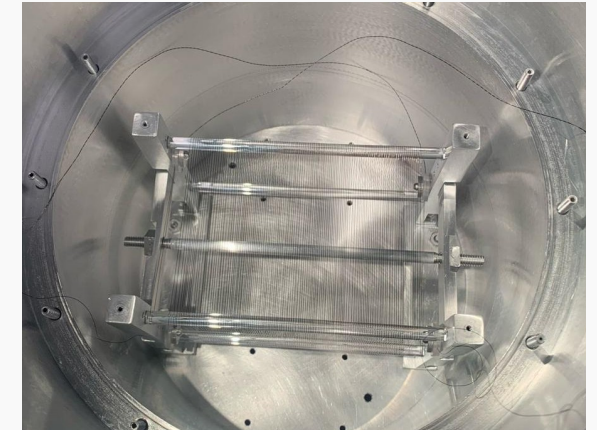
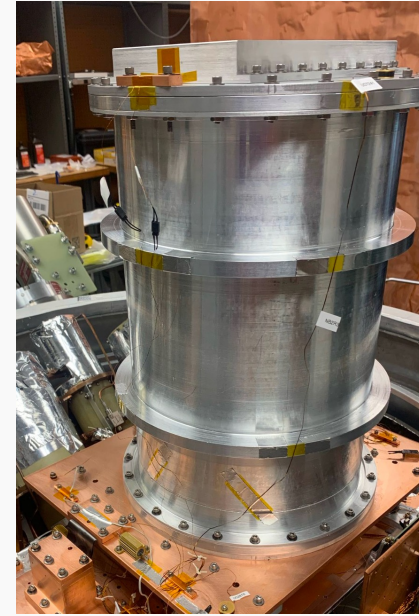

Based off of work in Chaudhuri Group (Princeton).

Highest measured Qs for kHz resonators:  
 $Q > 2,000,000$

Kolevatov, Chaudhuri, Page. *Rev. Sci. Instrum.* 97, 024503 (2026)

# DMRadio-50L sheath

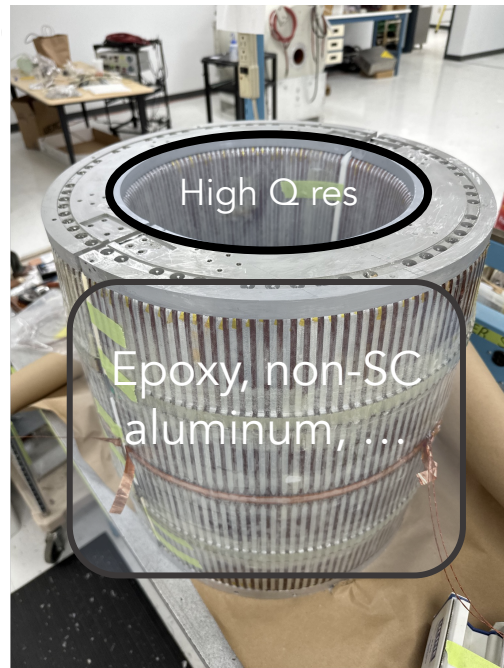

Resistive + dielectric loss from magnet couples into high Q resonator.

This degrades the Q

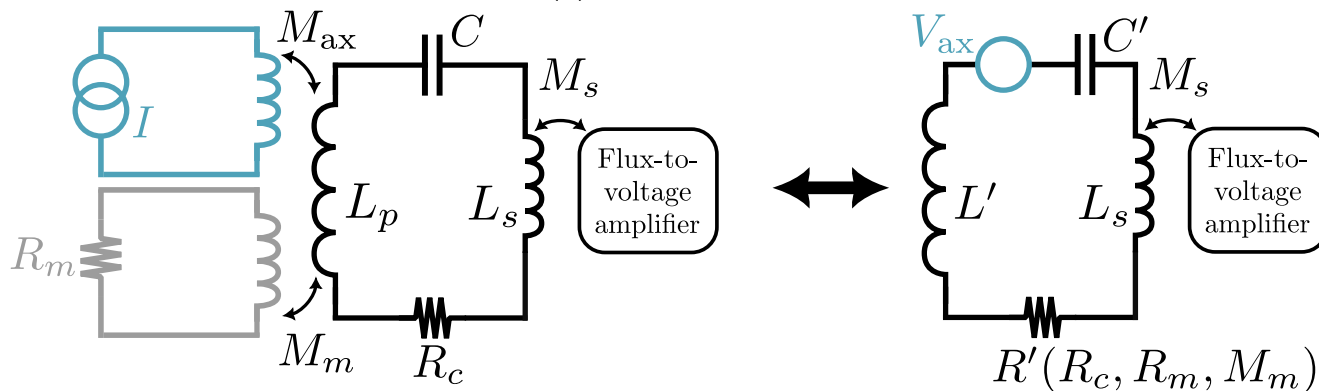

# DMRadio-50L sheath

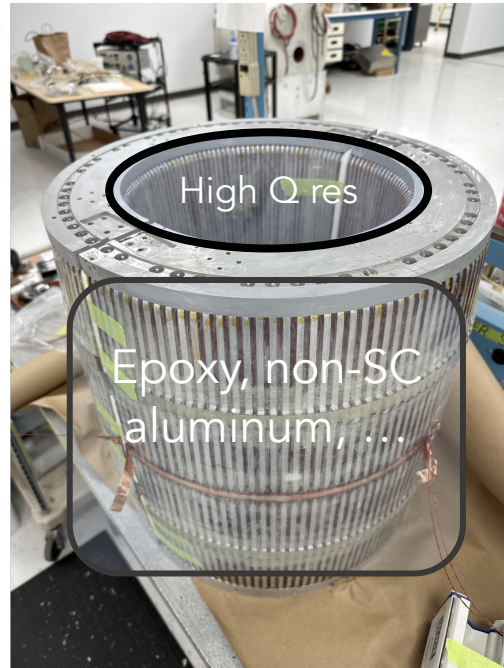

Resistive + dielectric loss from magnet couples into high Q resonator.

This degrades the Q

Enclose magnet in superconducting Nb sheath. Slits + sleeves allow axion signal to propagate out while cutting off noise

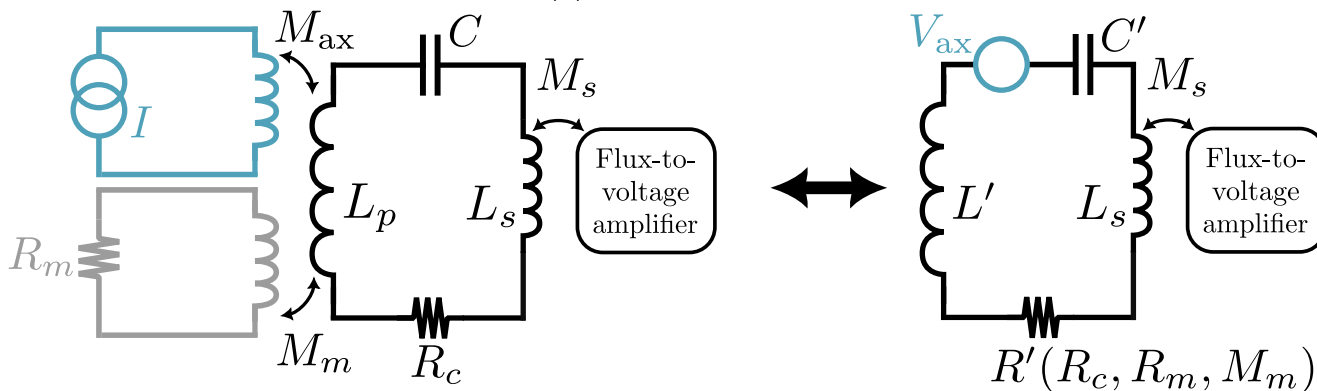
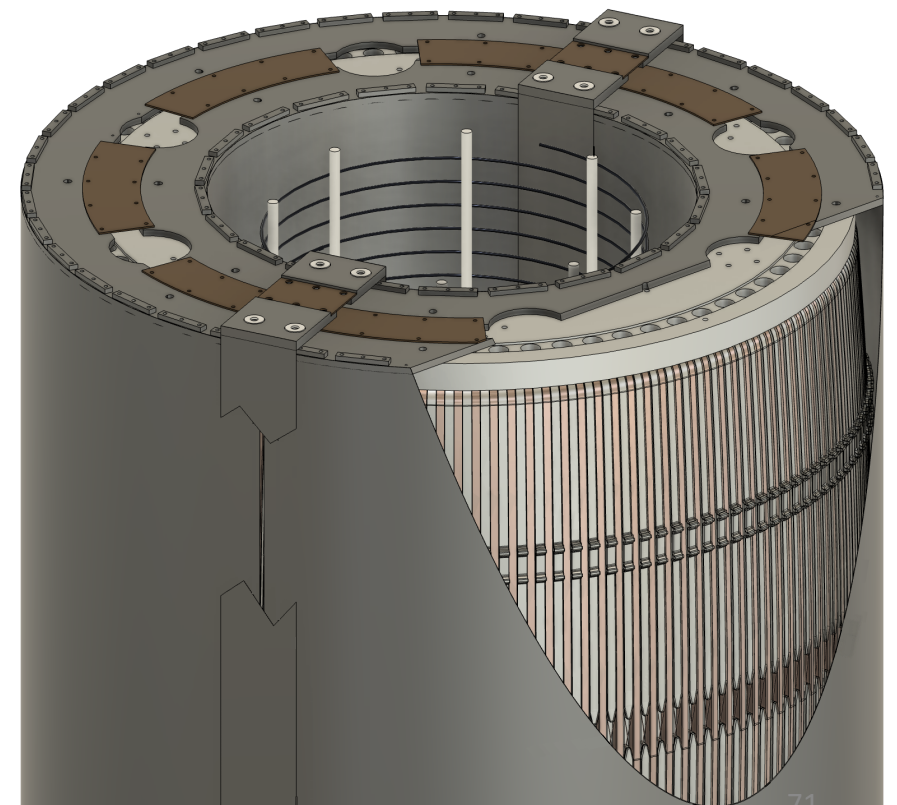

# DMRadio-50L readout: SQUIDs + RQUs

SQUIDs

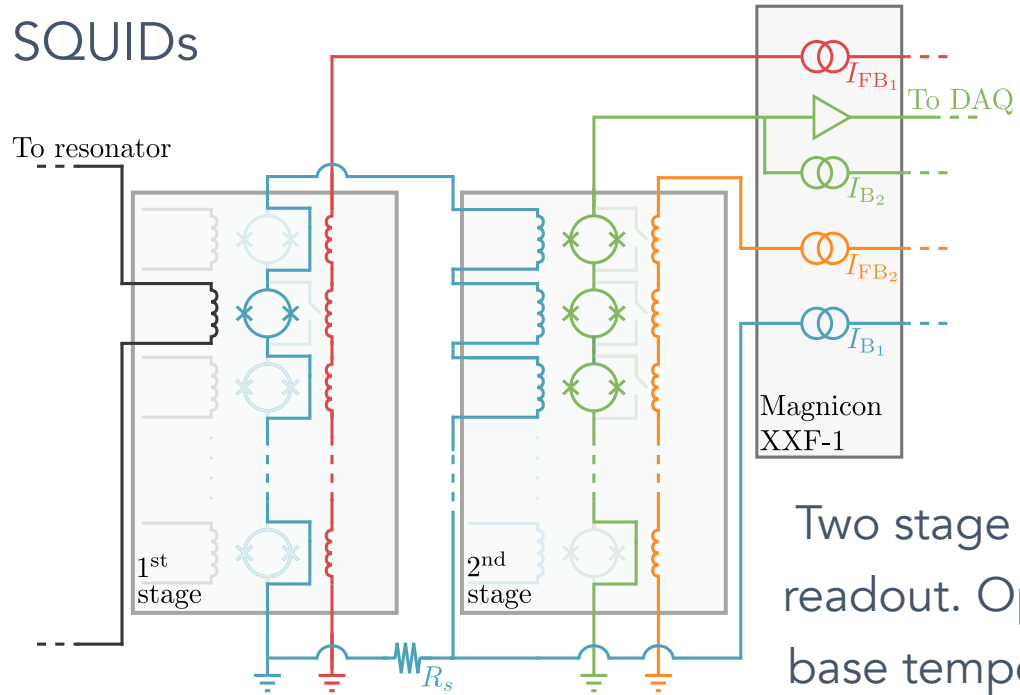

Two stage dc SQUID readout. Operating at base temperature (50 mK)

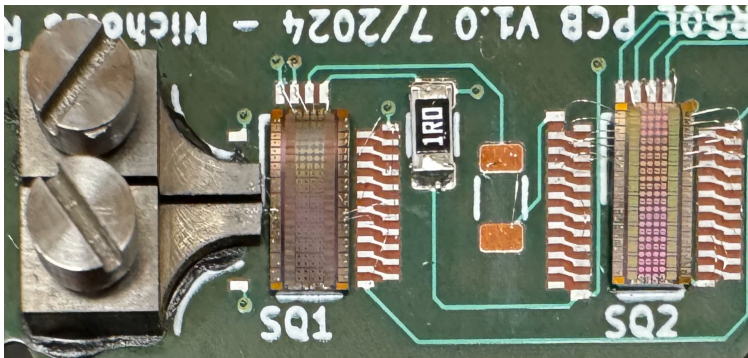

# DMRadio-50L readout: SQUIDs + RQUs

SQUIDs

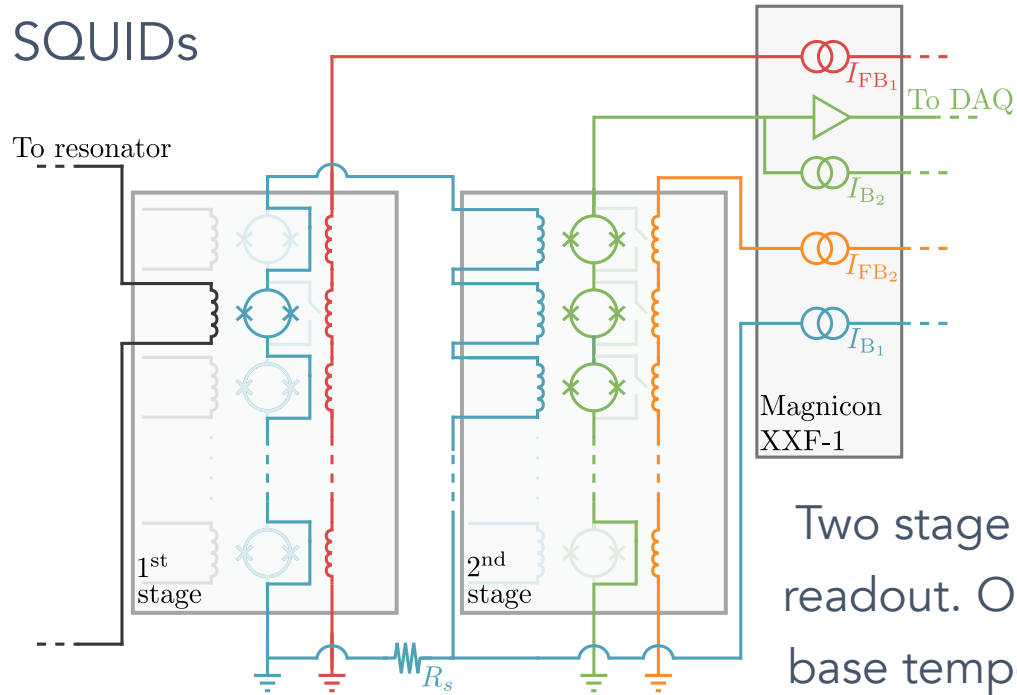

Two stage dc SQUID readout. Operating at base temperature (50 mK)

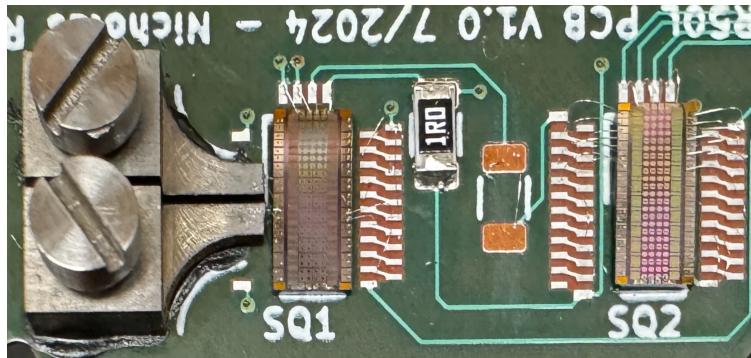

Radiofrequency Quantum Upconverters (RQUs)

Microwave (4-8 GHz) drive

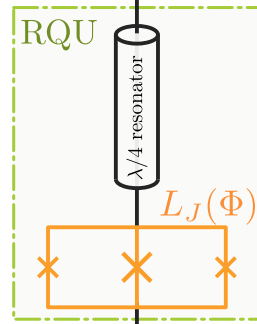
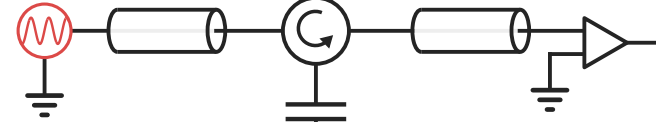

SQL evading techniques through backaction evasion

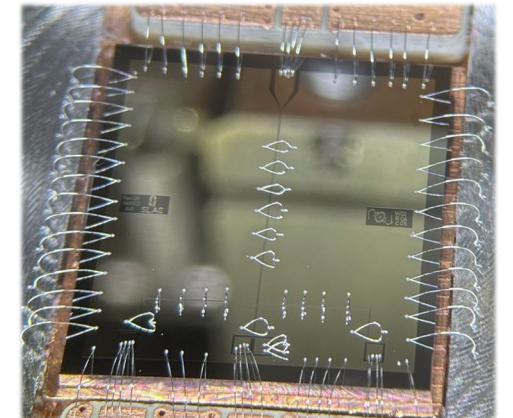
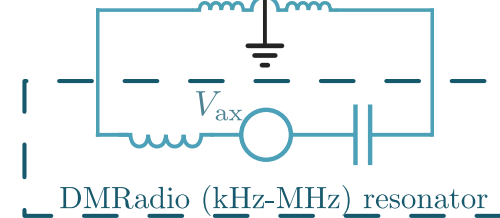

# DMRadio-50L next steps

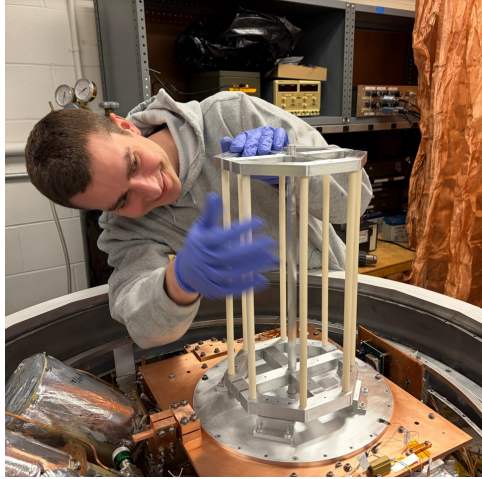

Resonator  
integration

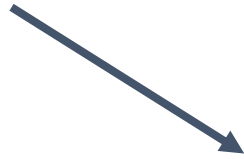

Data Acquisition validation

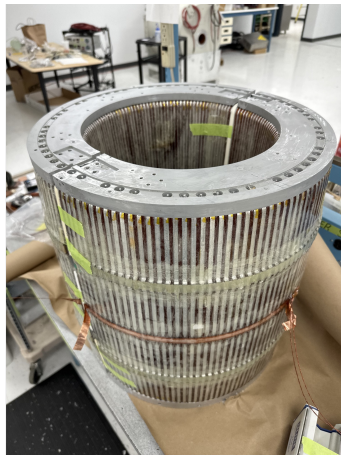

Magnet  
integration

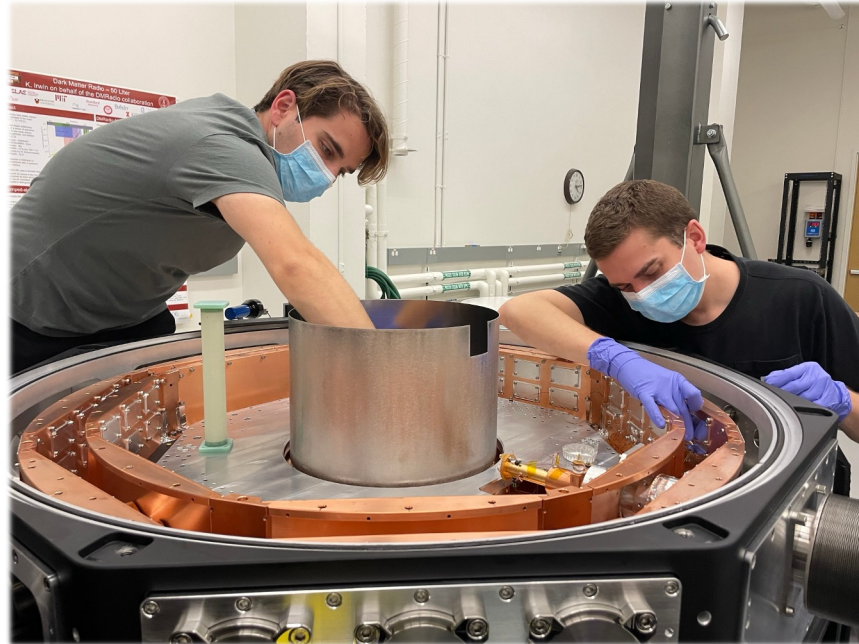
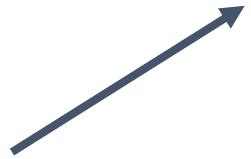

First science  
data soon

# Outline

Strong CP problem

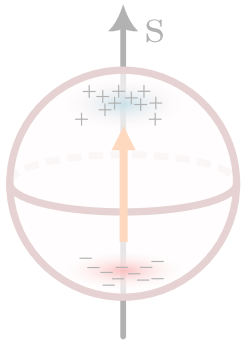

Dark matter



Dark matter axions

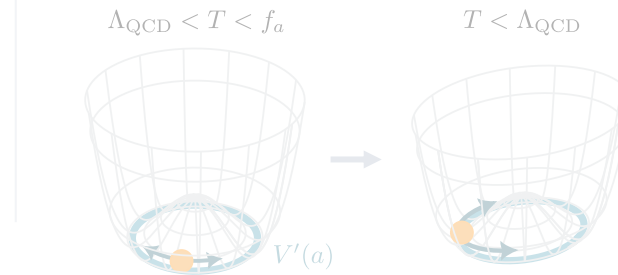

Axion-Standard Model interactions

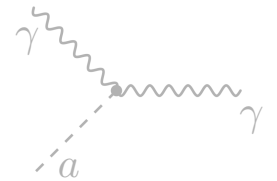

## DMRadio

Ongoing implementation

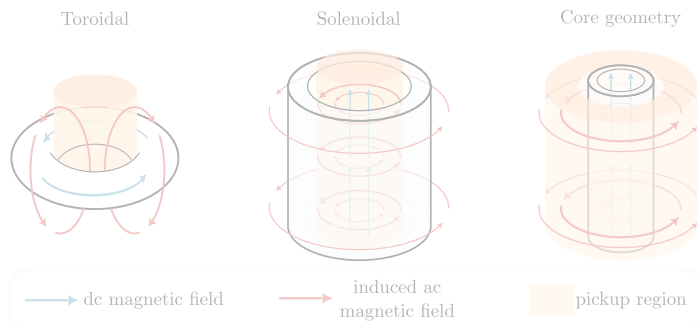

DMRadio-50L

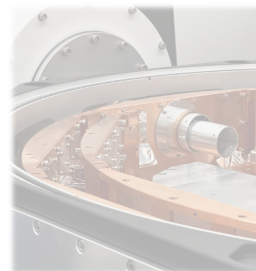

Designs of next generation

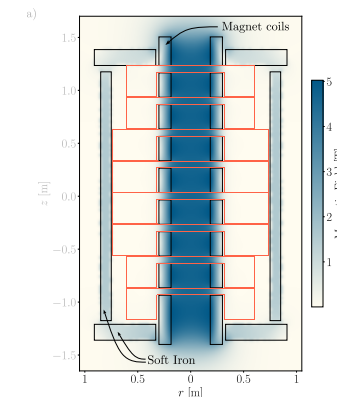

DMRadio-Core, DMRadio-GUT

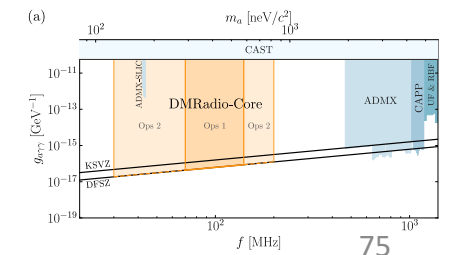

# A higher frequency, more sensitive experiment

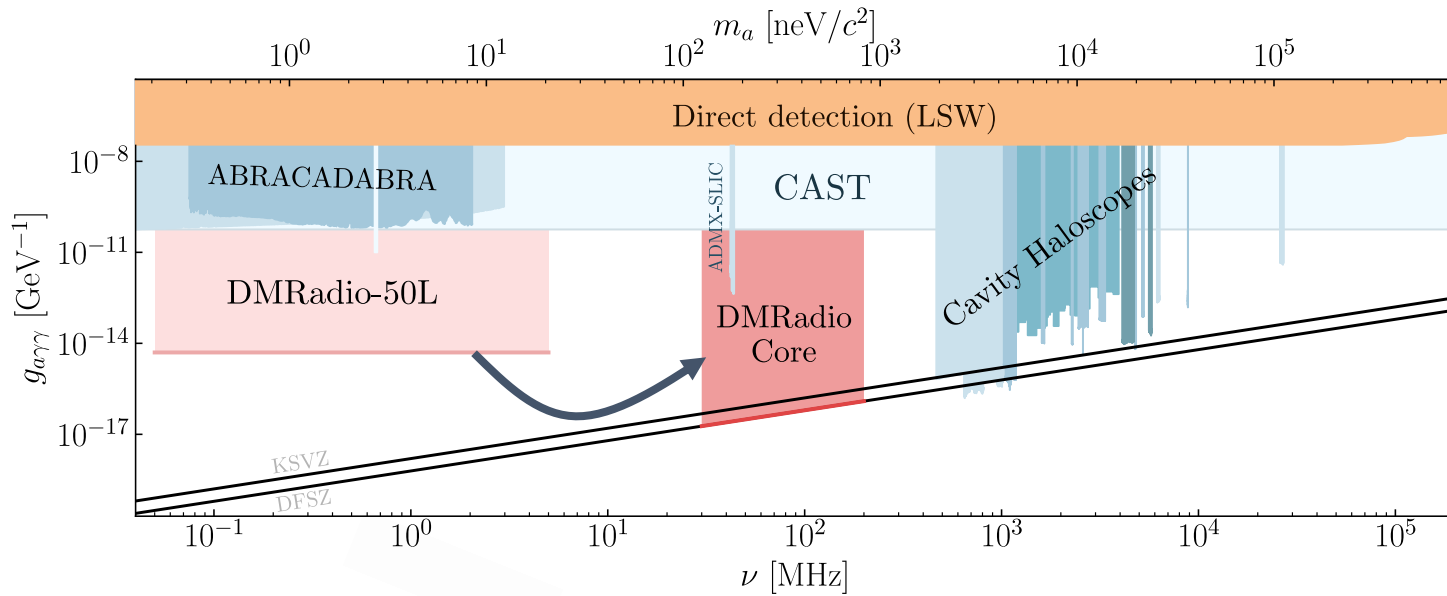

How do we quantify how “good” an experiment is?

# A higher frequency, more sensitive experiment

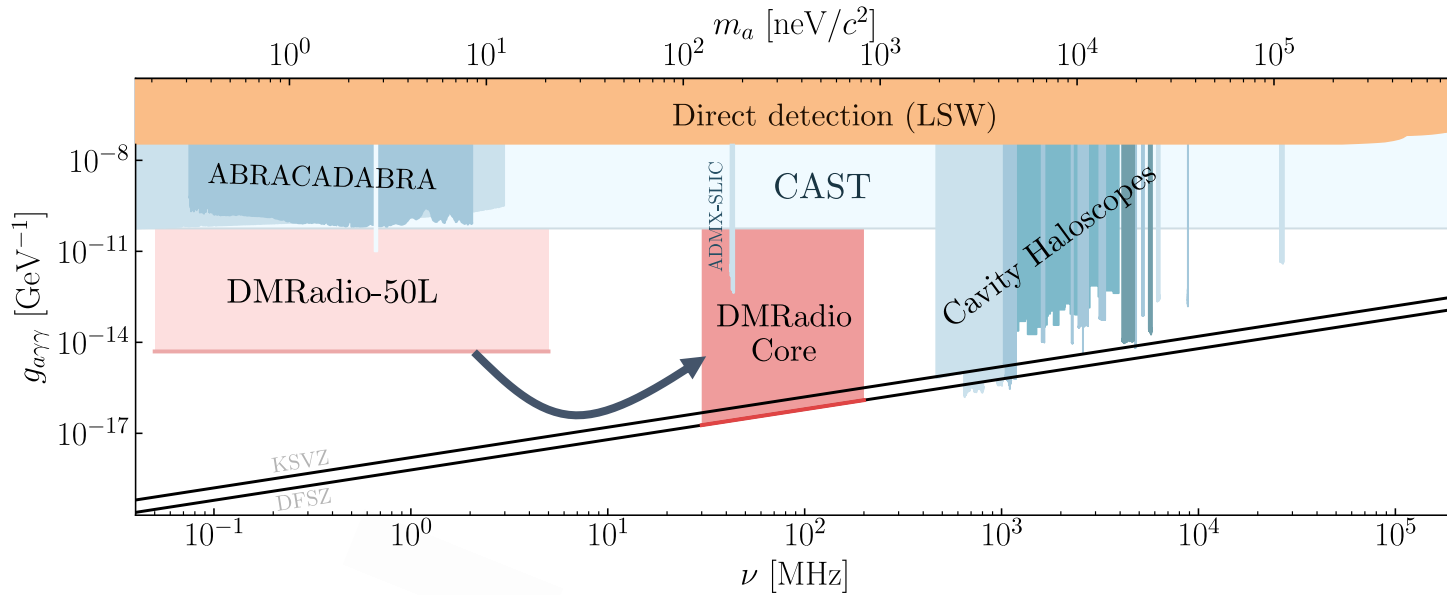

How do we quantify how “good” an experiment is?

Define the “scan rate”

How quickly can the resonator be scanned such that we conclude whether an axion is there at a given coupling?

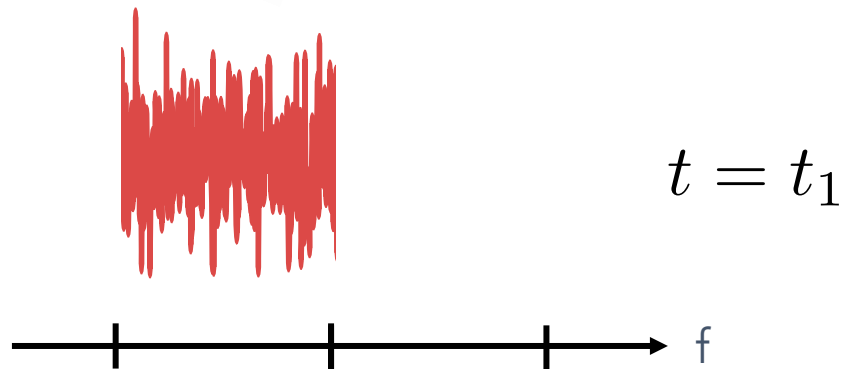

# A higher frequency, more sensitive experiment

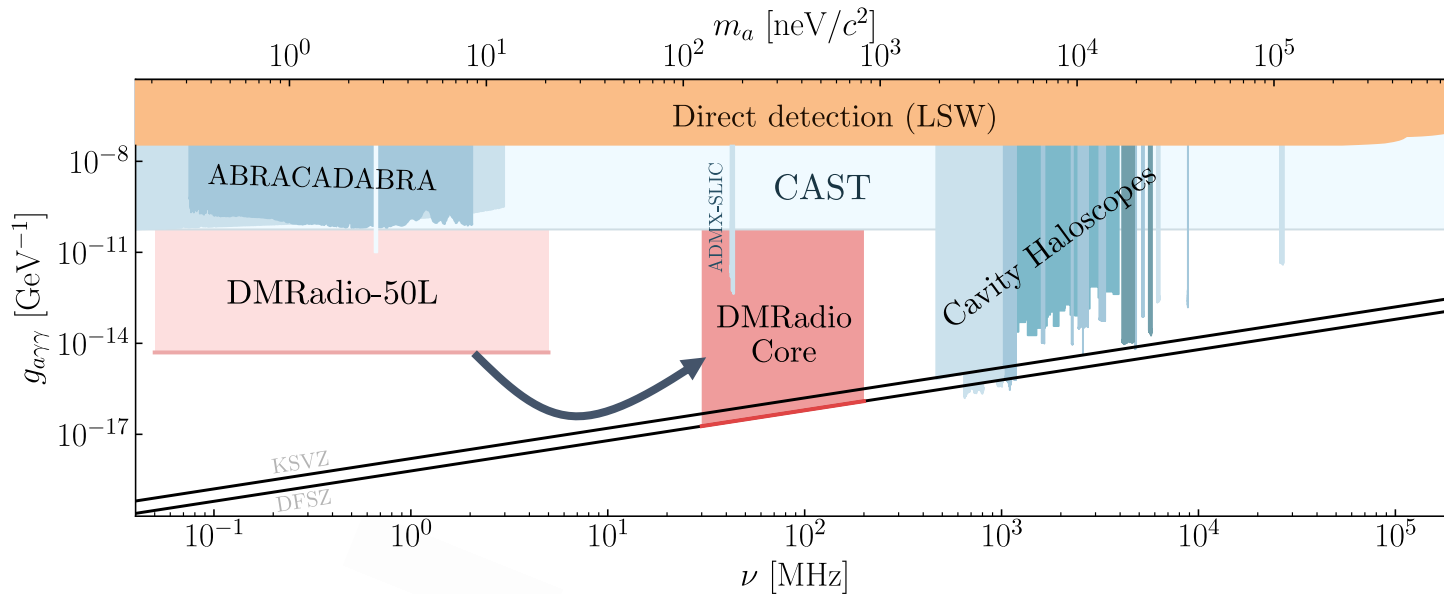

How do we quantify how “good” an experiment is?

Define the “scan rate”

How quickly can the resonator be scanned such that we conclude whether an axion is there at a given coupling?

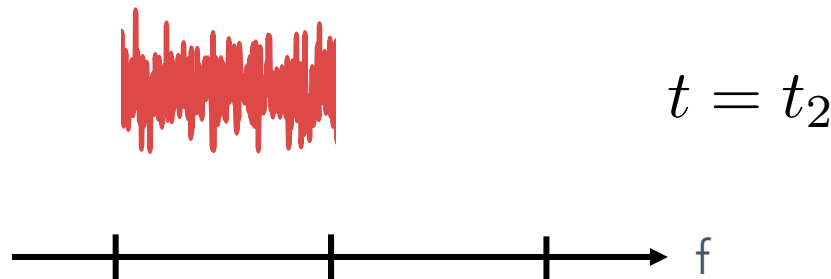

# A higher frequency, more sensitive experiment

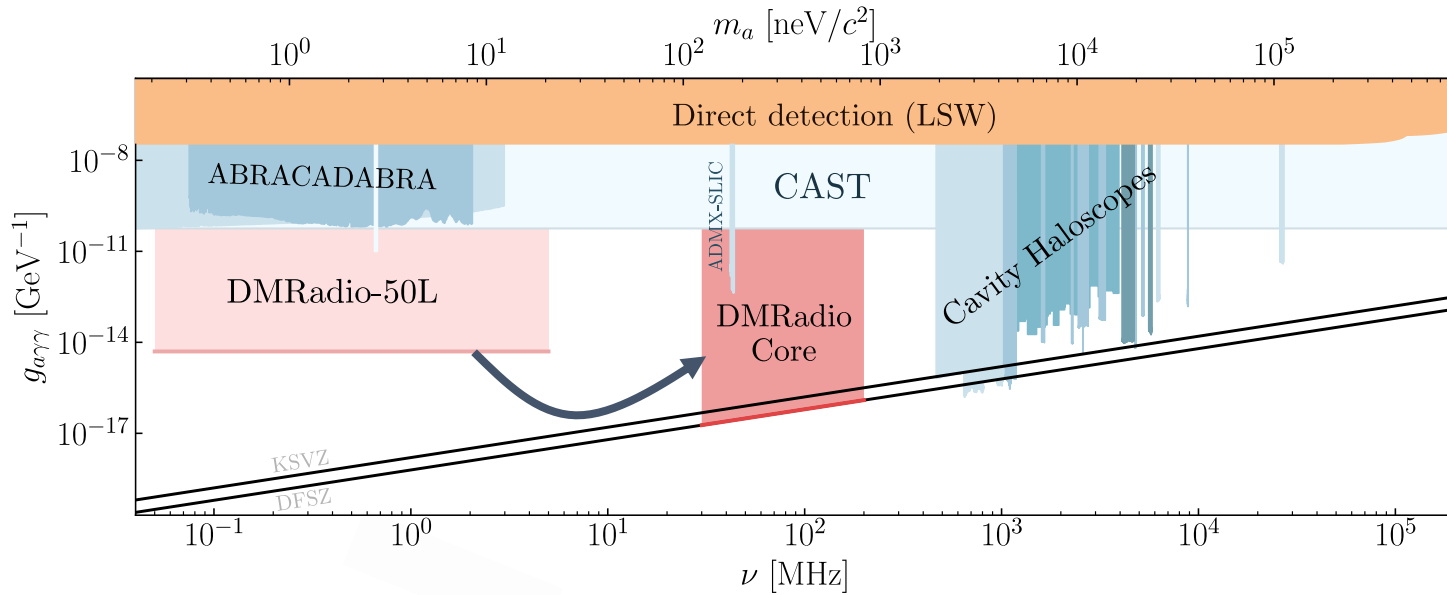

How do we quantify how “good” an experiment is?

Define the “scan rate”

How quickly can the resonator be scanned such that we conclude whether an axion is there at a given coupling?



$t = t_3$



# A higher frequency, more sensitive experiment

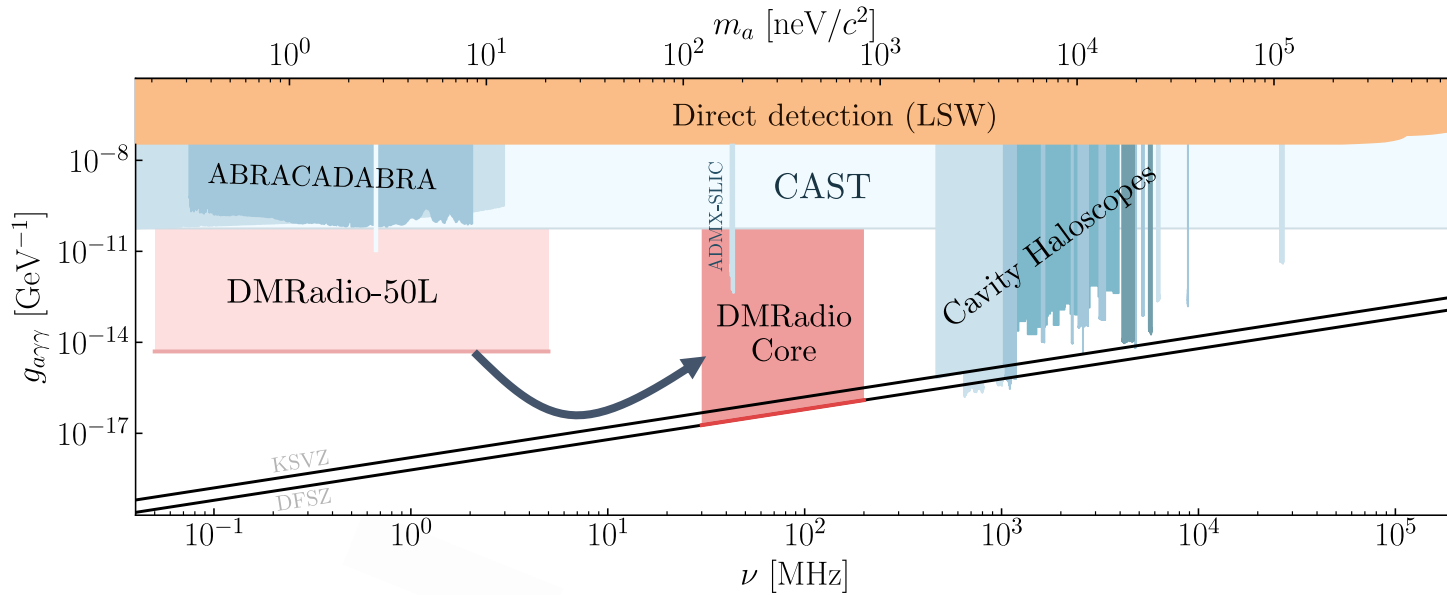

How do we quantify how “good” an experiment is?

Define the “scan rate”

How quickly can the resonator be scanned such that we conclude whether an axion is there at a given coupling?

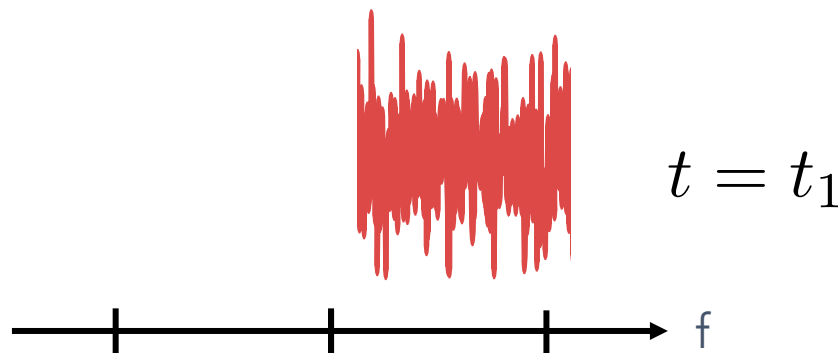

# A higher frequency, more sensitive experiment

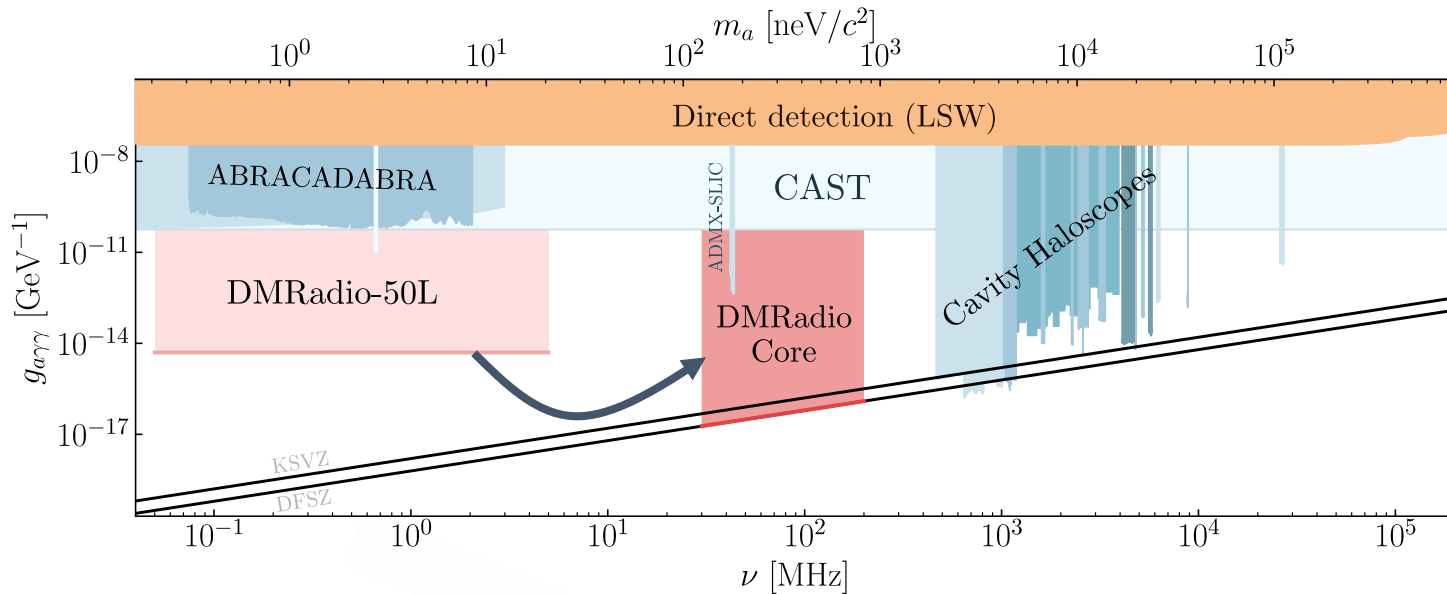

How do we quantify how “good” an experiment is?

Define the “scan rate”

How quickly can the resonator be scanned such that we conclude whether an axion is there at a given coupling?

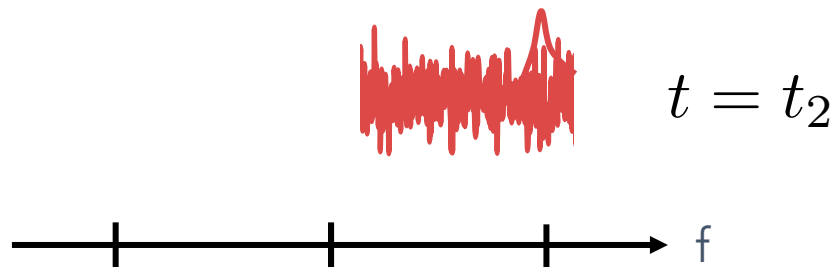

# A higher frequency, more sensitive experiment

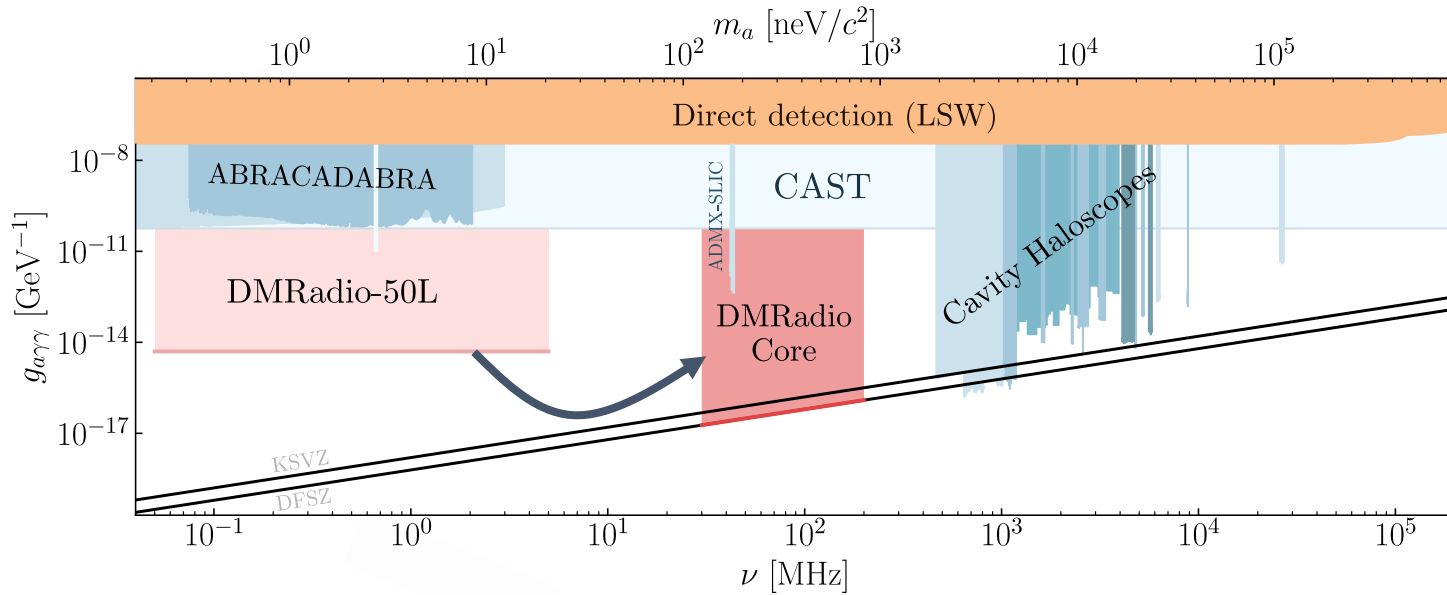

How do we quantify how “good” an experiment is?

Define the “scan rate”

How quickly can the resonator be scanned such that we conclude whether an axion is there at a given coupling?

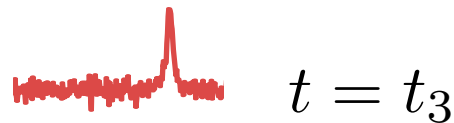

# A higher frequency, more sensitive experiment

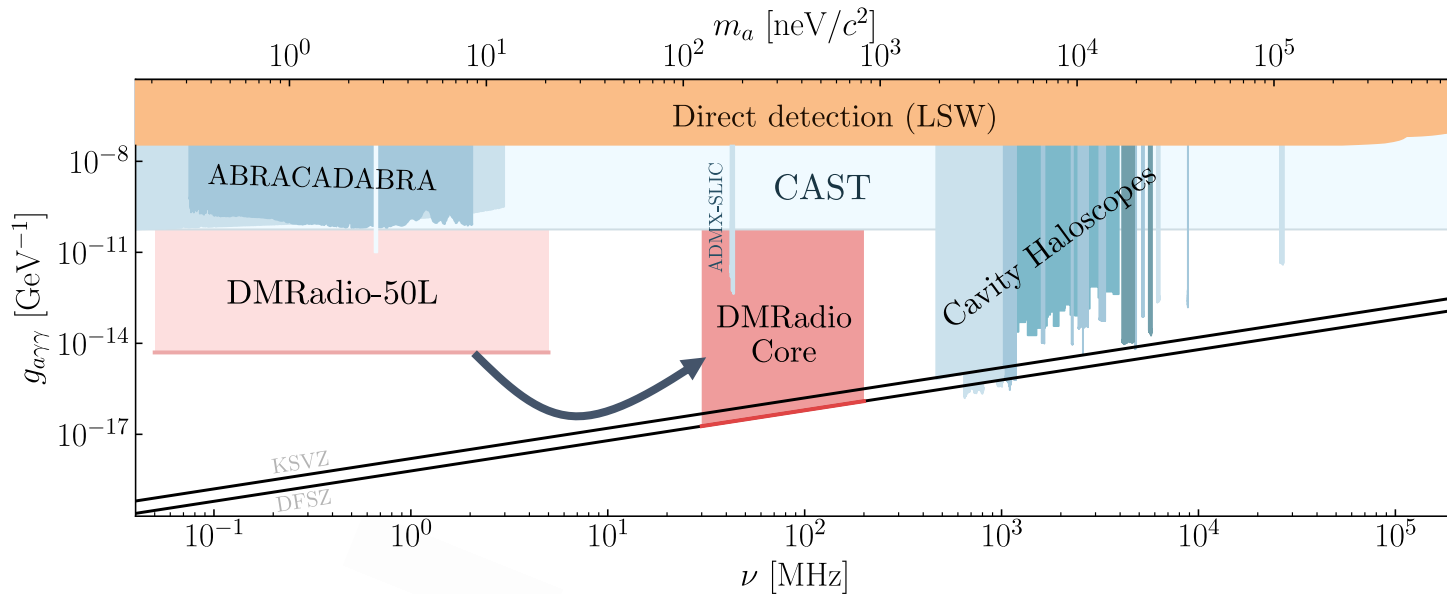

How do we quantify how “good” an experiment is?

Define the “scan rate”

How quickly can the resonator be scanned such that we conclude whether an axion is there at a given coupling?

$$\frac{d\nu}{dt} \sim \frac{g_{a\gamma\gamma}^4 \rho_{\text{DM}}^2 \nu_r B^4 V^{10/3} Q}{\text{SNR}^2 \eta}$$

Scaling for a constant geometry that's scaled linearly in all dimensions

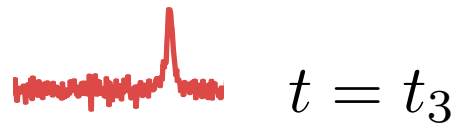

Want: stronger magnets, higher volumes, higher Qs, lower noise amplifiers!

# Larger volumes, stronger magnets. New geometries?

Toroidal

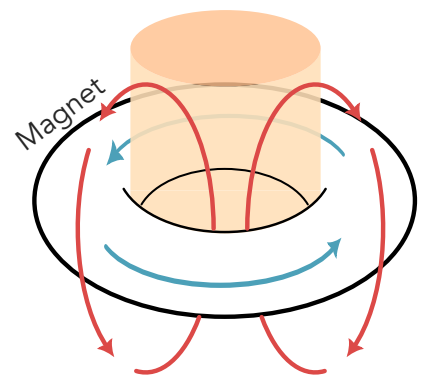

→ dc magnetic field      → induced ac magnetic field      pickup region

# Larger volumes, stronger magnets. New geometries?

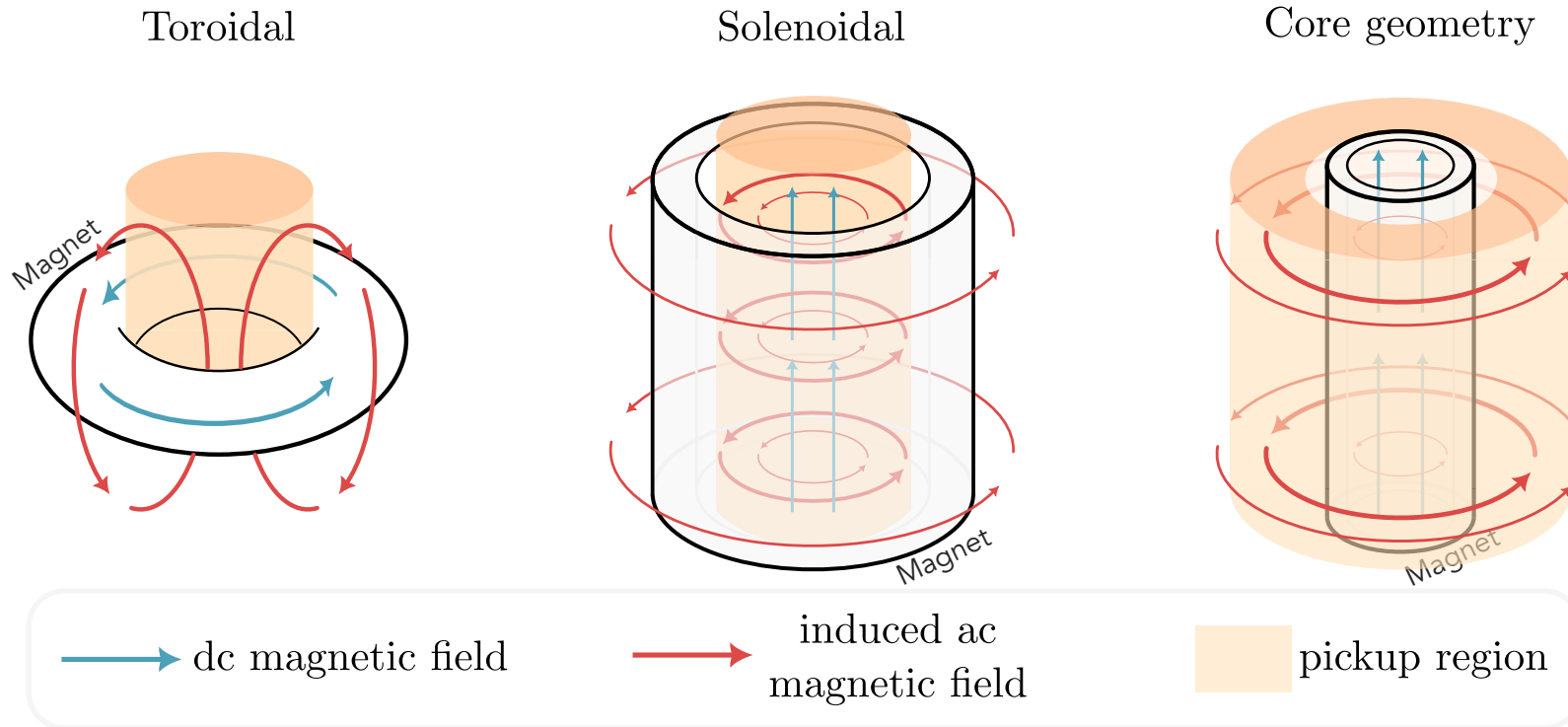

Core geometry is optimal! This wasn't appreciated until recently

First focus on **DMRadio-m<sup>3</sup>** which uses **solenoidal** geometry

# Comparing geometries and introducing Core geometry

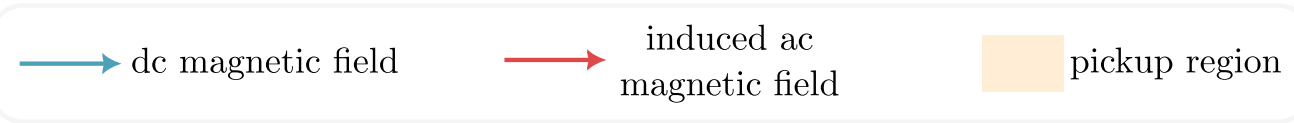

Toroidal

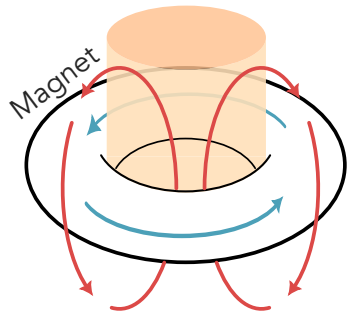

Fully enclosed magnetic fields

Straightforward implementation of  
superconducting components

Toroidal magnets are harder to build

Toroidal geometry does not have  
good scaling for larger experiments

# Comparing geometries and introducing Core geometry

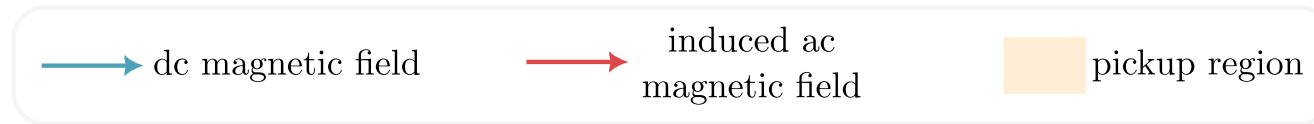

Toroidal

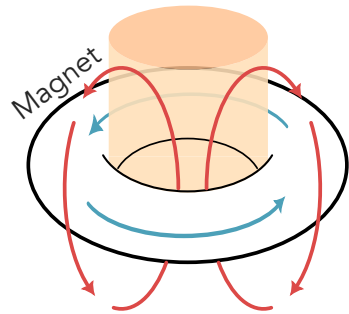

Fully enclosed magnetic fields

Straightforward implementation of superconducting components

Toroidal magnets are harder to build

Toroidal geometry does not have

good scaling for larger experiments

Solenoidal

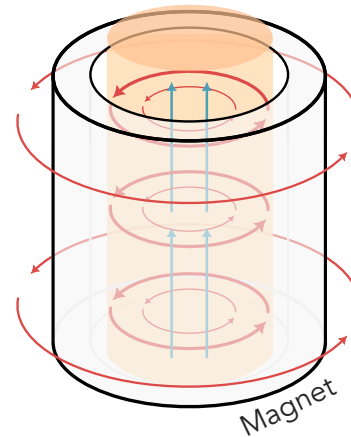

Solenoidal magnets are easier

Very high stored magnet energy

Non-natural use of superconducting elements

# Comparing geometries and introducing Core geometry



Toroidal

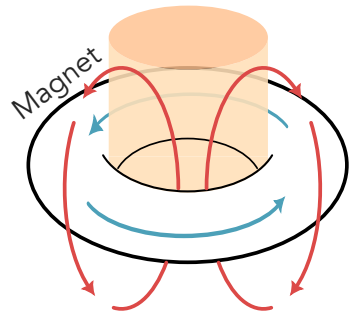

Fully enclosed magnetic fields

Straightforward implementation of superconducting components

Toroidal magnets are harder to build

Toroidal geometry does not have

good scaling for larger experiments

Solenoidal

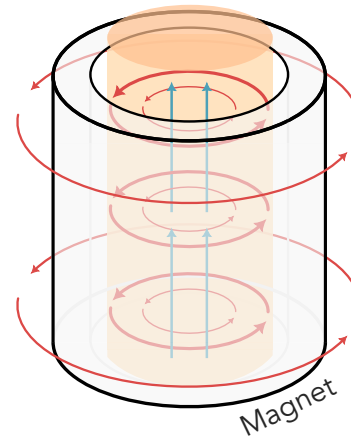

Solenoidal magnets are easier

Very high stored magnet energy

Non-natural use of superconducting elements

Core geometry

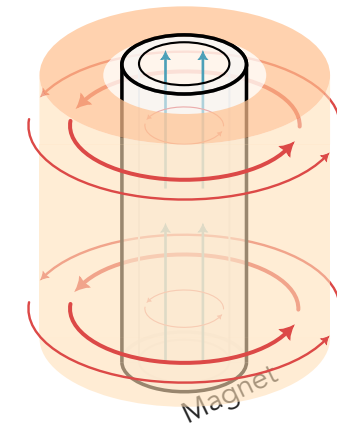

Smaller bore solenoidal magnets

Lower magnet energy

Natural use of superconducting elements

# Comparing geometries and introducing Core geometry

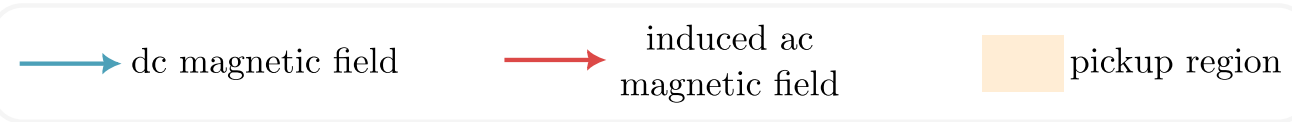

Toroidal



Fully enclosed magnetic fields

Straightforward implementation of superconducting components

Toroidal magnets are harder to build

Toroidal geometry does not have

good scaling for larger experiments

Solenoidal

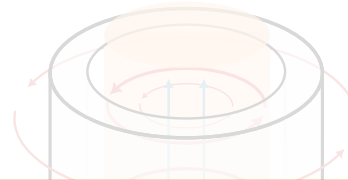

The core geometry is ideal for next gen DMRadio experiments

Solenoidal magnets are easier

Very high stored magnet energy

Non-natural use of superconducting elements

Core geometry

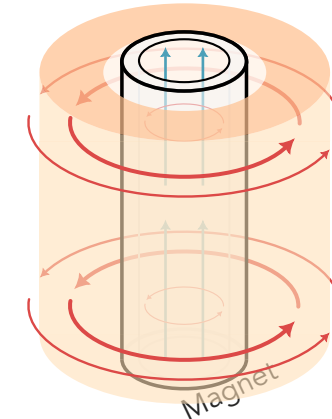

Smaller bore solenoidal magnets

Lower magnet energy

Natural use of superconducting elements

# Solenoidal magnets and pickup geometries

Axion current produces **ac magnetic field** inside and outside the solenoidal magnet

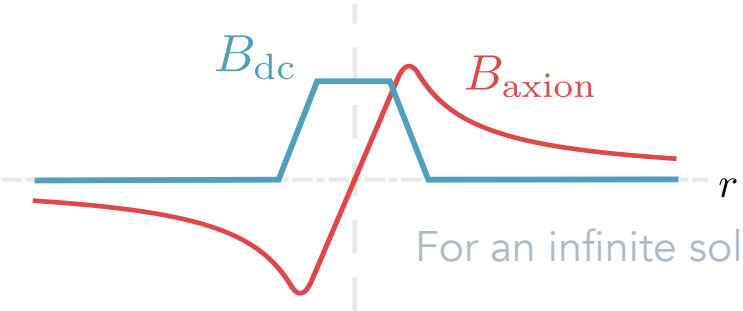
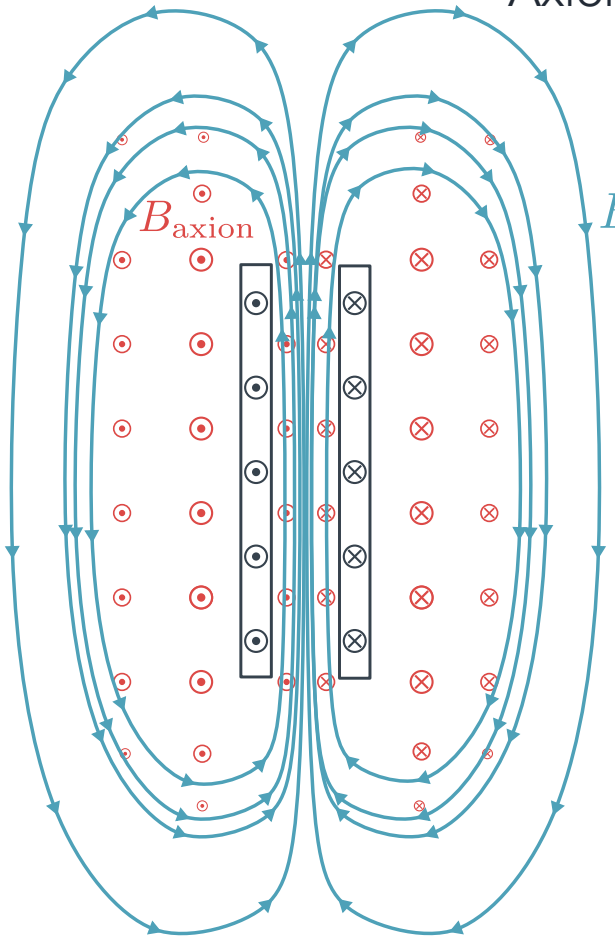

For an infinite solenoid

# Solenoidal magnets and pickup geometries

Axion current produces **ac magnetic field** inside and outside the solenoidal magnet

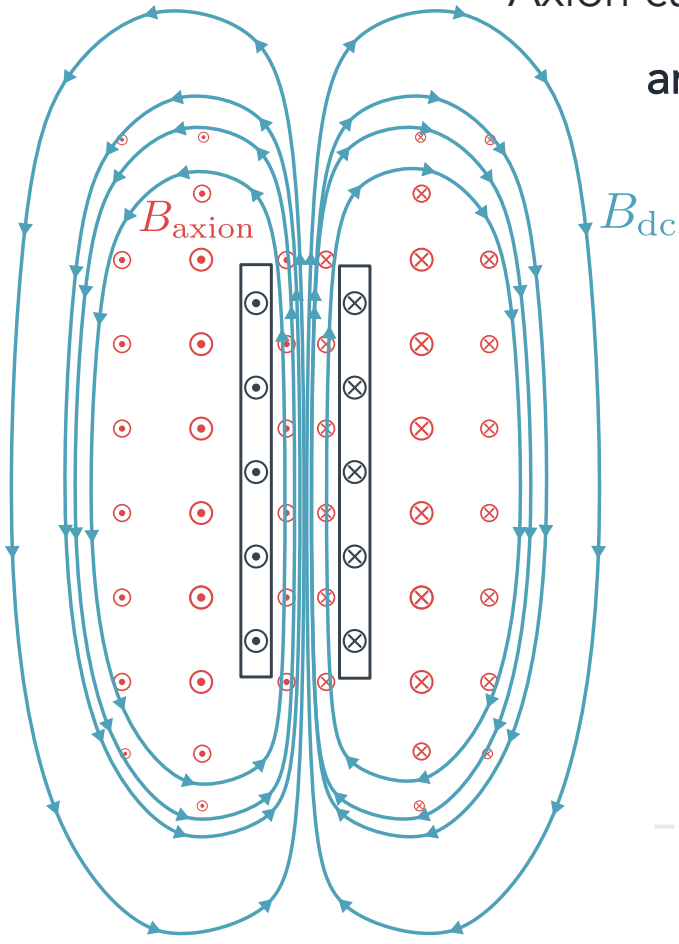

Couple to  $B_{ax} \sim 1/r$  outside of magnet by placing magnet inside the core of a coaxial pickup.

Design magnet such that this region is in **low dc field**  $\rightarrow$  superconducting pickup and electronics

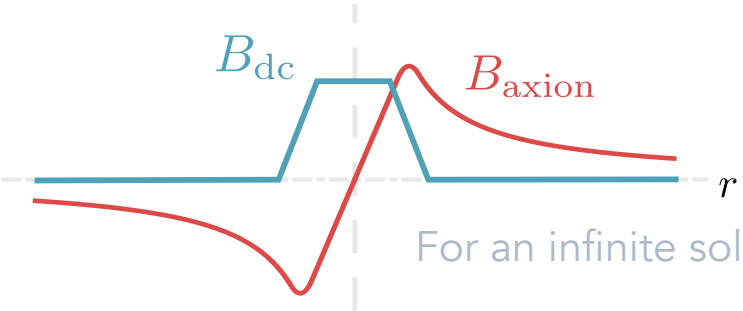
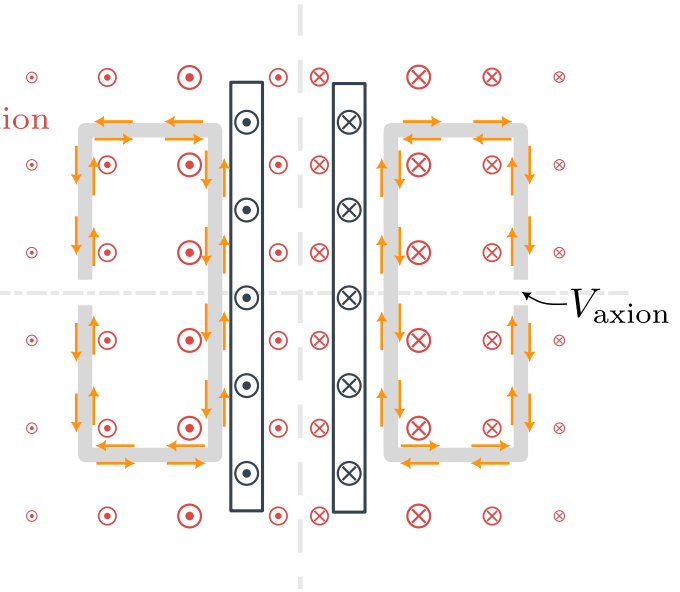

This is the **DMRadio-Core** geometry

# Optimal pickup geometry

Optimal pickup geometries uses closed pickup structure intersecting magnetic field lines

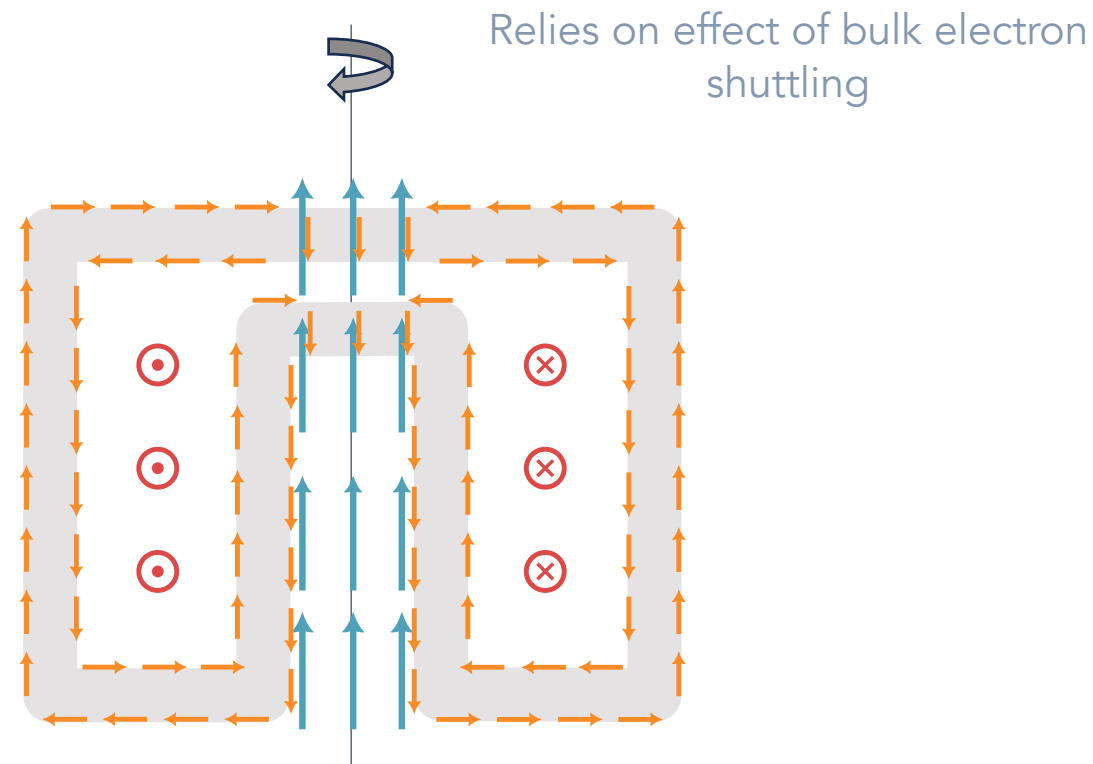

Measure induced ac B-fields

# Optimal pickup geometry

Optimal pickup geometries uses closed pickup structure intersecting magnetic field lines

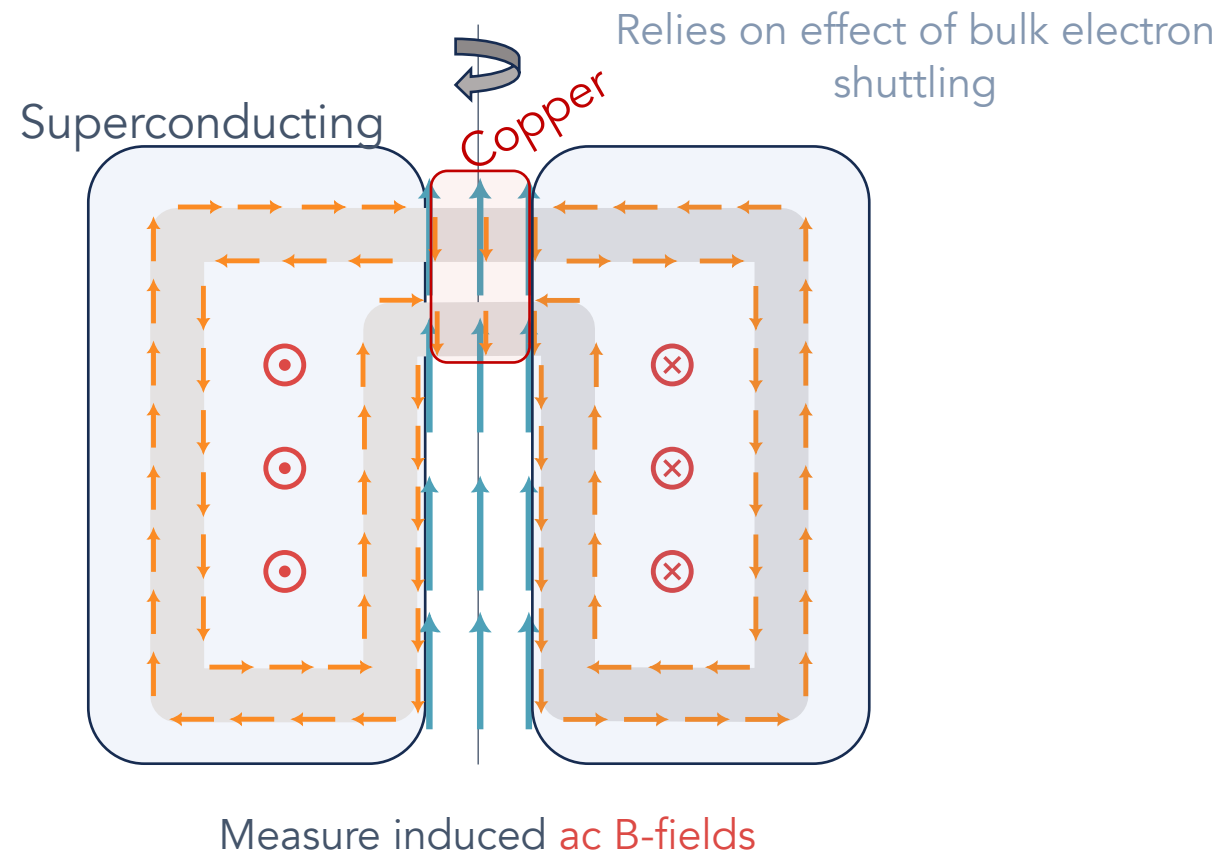

# Stackable pickups

Pickups can be stacked vertically and their voltages added

This geometry is the backbone of  
DMRadio-Core and the DMRadio-  
GUT

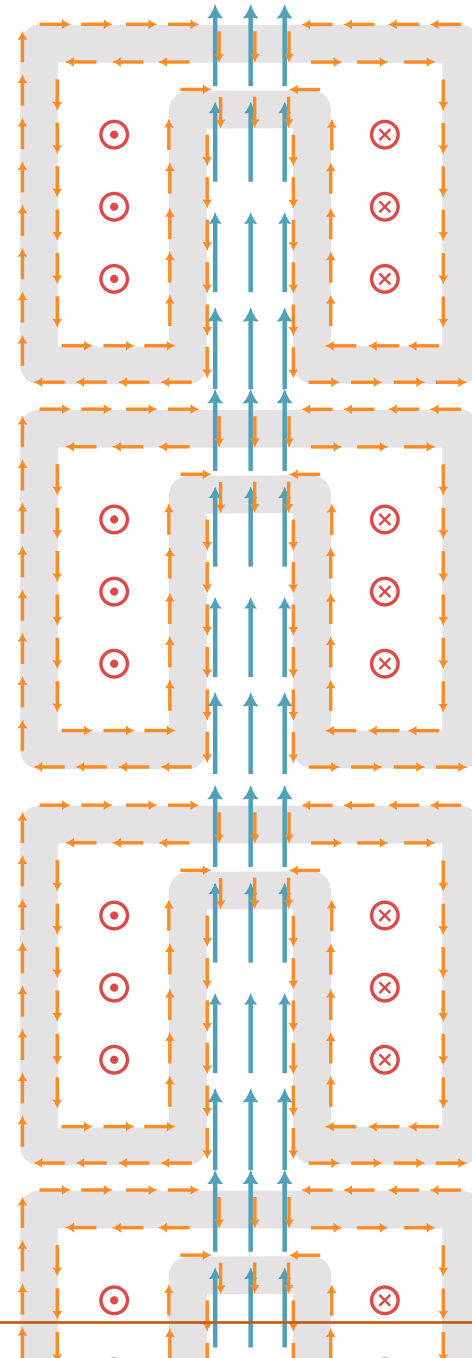

# DMRadio-Core

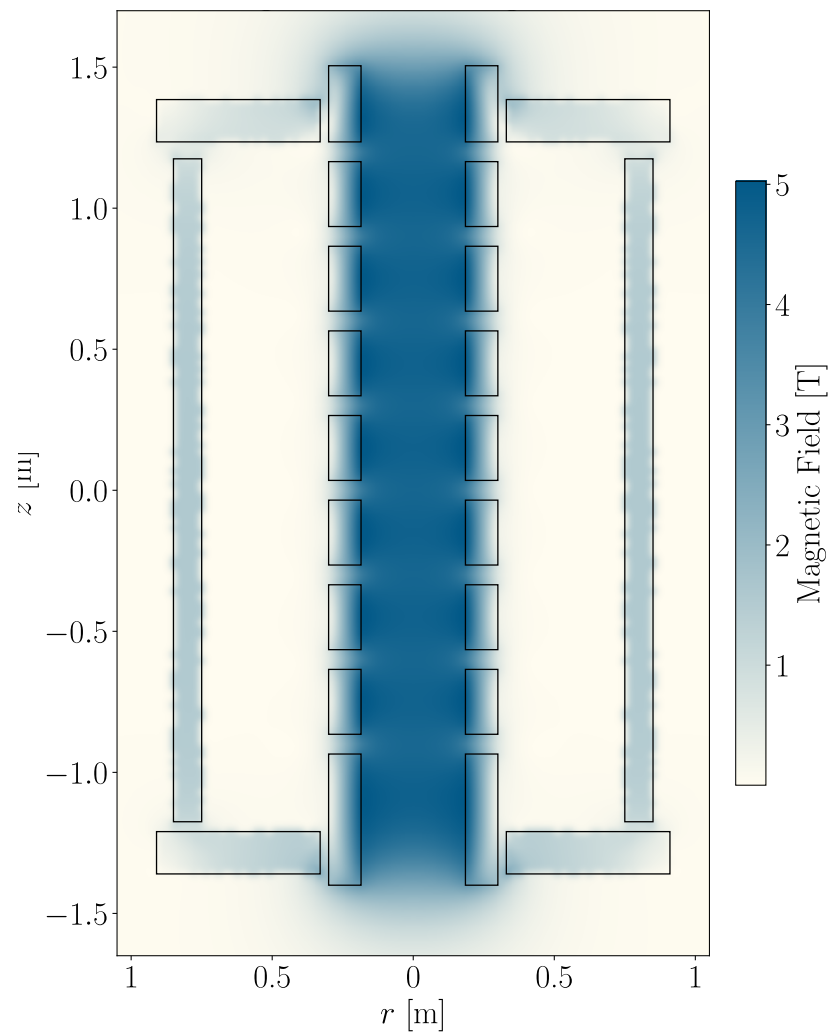

Solenoidal magnets are easier to employ than toroidal  
~10x lower magnet stored energy compared to DMRadio-m<sup>3</sup>

Pickups are superconducting

Superconducting readout elements

Much more efficient coupling to axion signal

LDRD submitted recently at SLAC

# DMRadio-Core Sensitivity

5T peak field, 60 cm bore,  
9 segments, 2.9 m length

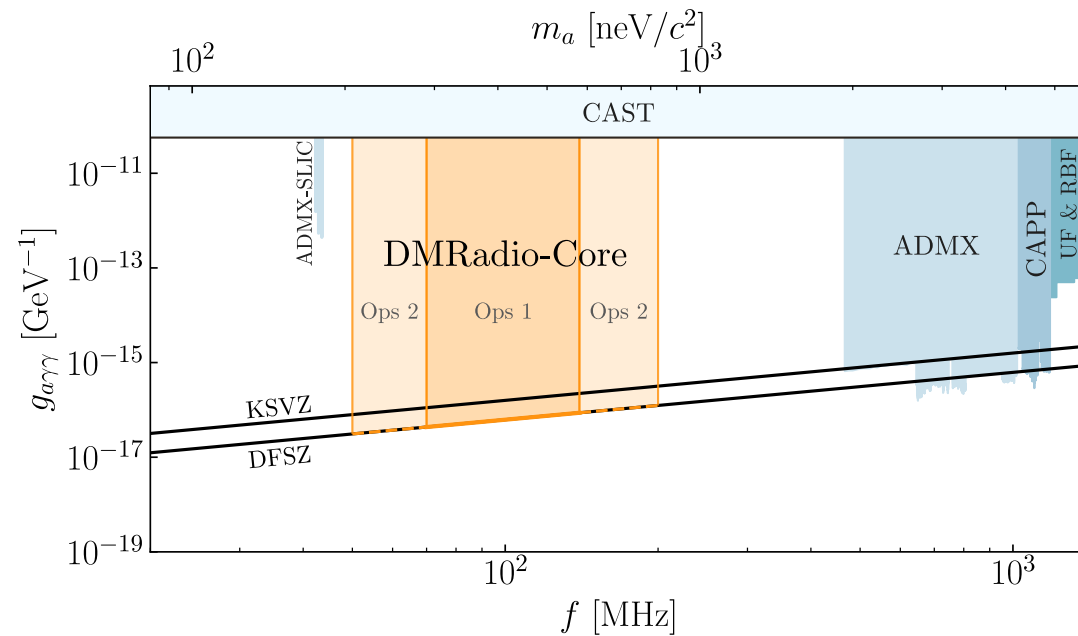

Eight pickups of two different sizes  $\rightarrow$  avoids cavity modes

Using optimized dc SQUIDs (see Ankel *et al. J.Appl.Phys. (2025)*)

$Q=10^6$

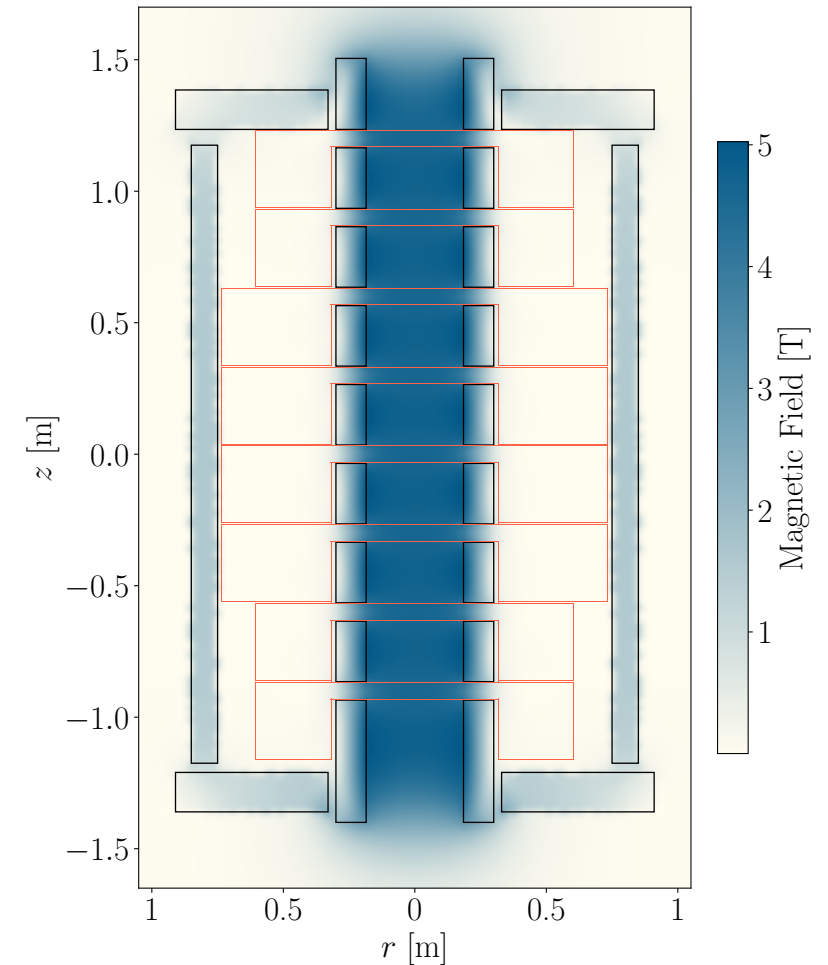

# DMRadio-Core Sensitivity

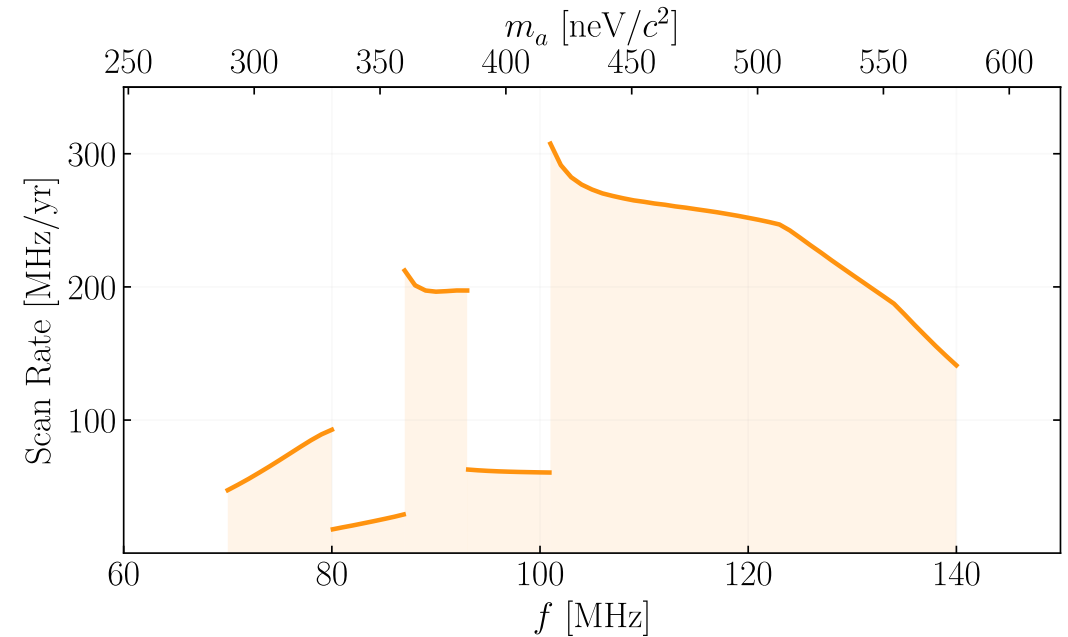
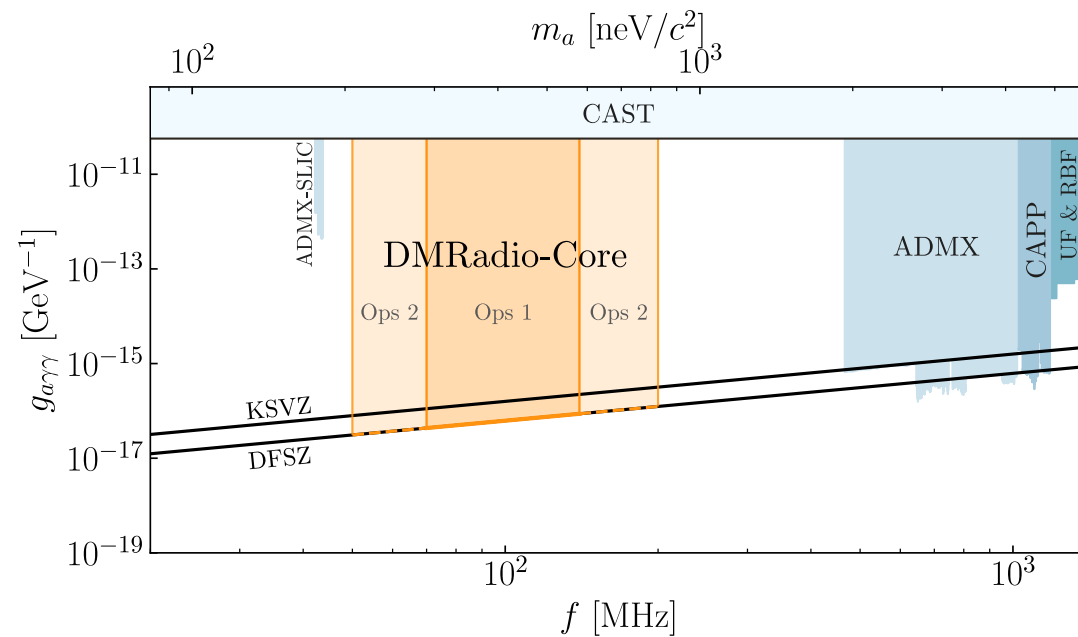

Eight pickups of two different sizes  $\rightarrow$  avoids cavity modes

Using optimized dc SQUIDs (see Ankel *et al. J.Appl.Phys. (2025)*)

$Q=10^6$

70-140 MHz DFSZ sensitivity, SNR = 3

0.75 yr live time

# Towards a GUT scale axion experiment

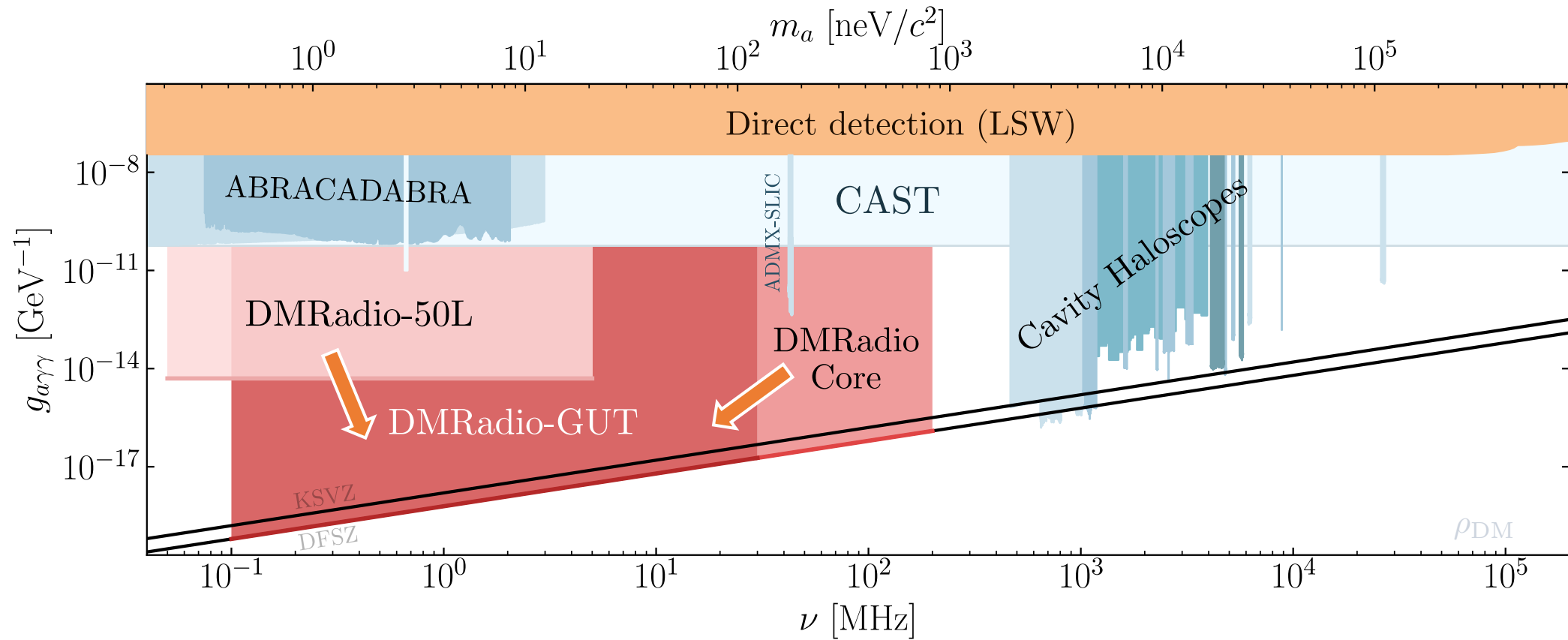

# Requirements for DMRadio-GUT

DFSZ axions down to 100 kHz

## Sub-SQL sensors

sub-SQL sensors at kHz frequencies with noise temperature  $\sim 0.1 \times hf$

*Radiofrequency quantum upconverters*

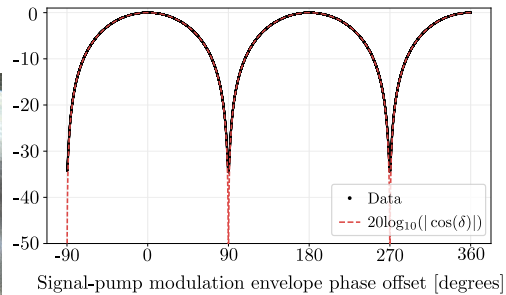
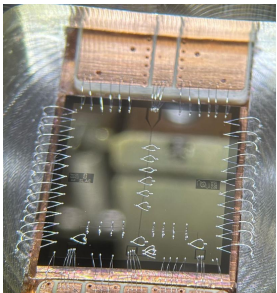

To be employed in DMRadio-50L

## High Q resonators

## Advanced magnet technologies

# Requirements for DMRadio-GUT

DFSZ axions down to 100 kHz

## Sub-SQL sensors

sub-SQL sensors at kHz frequencies with noise temperature  $\sim 0.1 \times hf$

*Radiofrequency quantum upconverters*

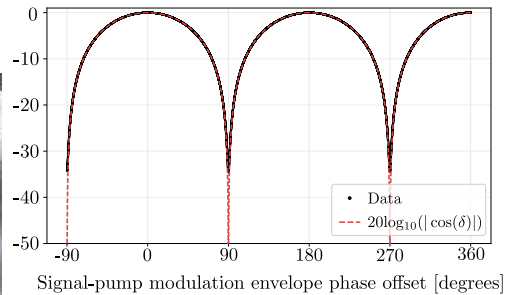
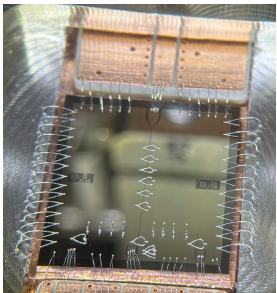

To be employed in DMRadio-50L

## High Q resonators

LC resonators with quality factor of  $\sim 10^7$ . Current record at  $2 \times 10^6$

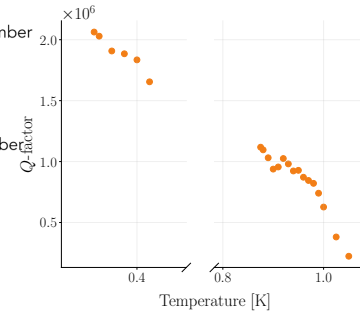
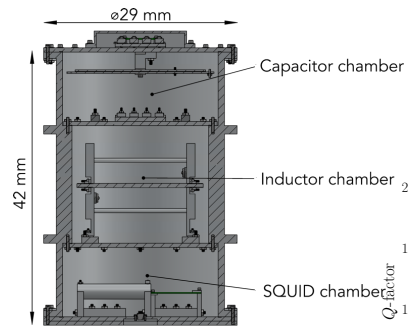

## Advanced magnet technologies

# Requirements for DMRadio-GUT

DFSZ axions down to 100 kHz

## Sub-SQL sensors

sub-SQL sensors at kHz frequencies with noise temperature  $\sim 0.1 \times hf$

*Radiofrequency quantum upconverters*

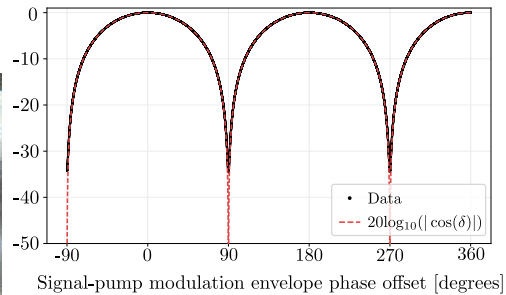
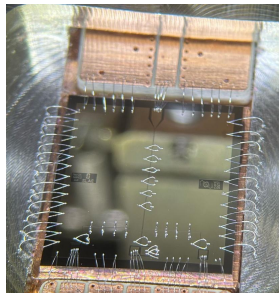

To be employed in DMRadio-50L

## High Q resonators

LC resonators with quality factor of  $\sim 10^7$ . Current record at  $2 \times 10^6$

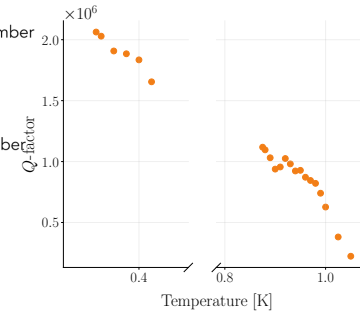
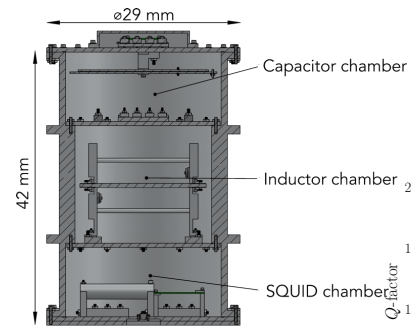

## Advanced magnet technologies

Requirements of  $>10$  T magnetic fields. R&D required for development of large high-field magnets

# Requirements for DMRadio-GUT

DFSZ axions down to 100 kHz

## Sub-SQL sensors

sub-SQL sensors at kHz frequencies with noise temperature  $\sim 0.1 \times hf$

Radiofrequency quantum upconverters

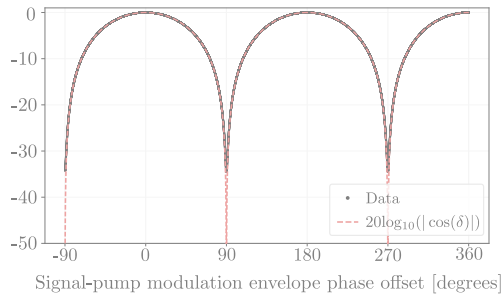
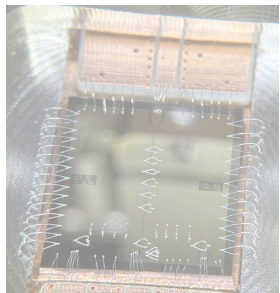

To be employed in DMRadio-50L

## High Q resonators

LC resonators with quality factor of  $\sim 10^7$ . Current reco

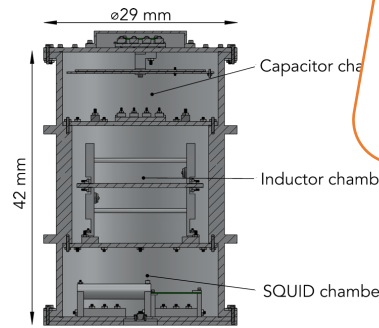

Core Geometry

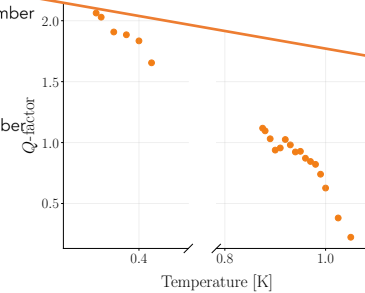

## Advanced magnet technologies

$\sim 10$  T magnetic fields. Development of large

# DMRadio-GUT: preliminary design

DFSZ axions down to 100 kHz

8.5 m tall, 18 T magnet

Sub-SQL sensors

2.2 year live time

First design of DMRadio-GUT geometry

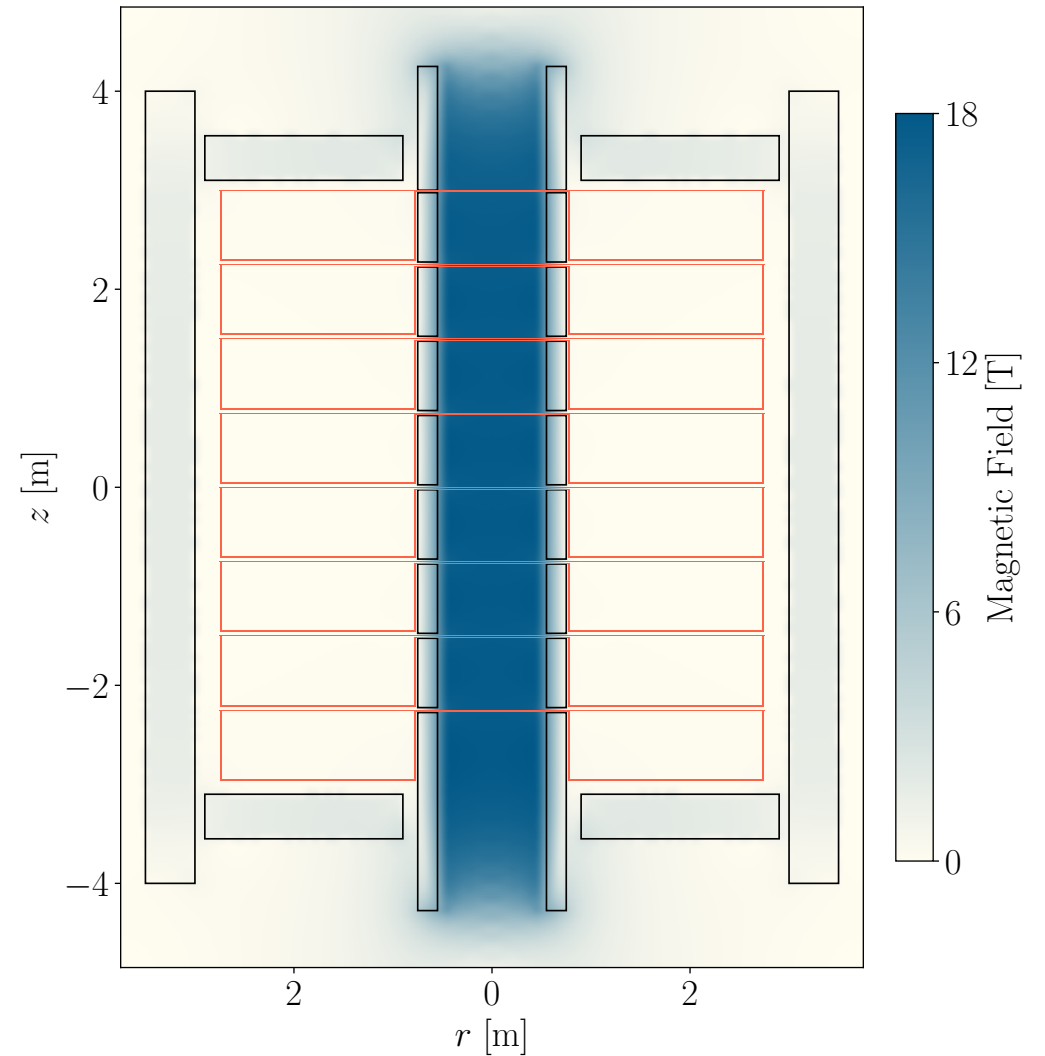
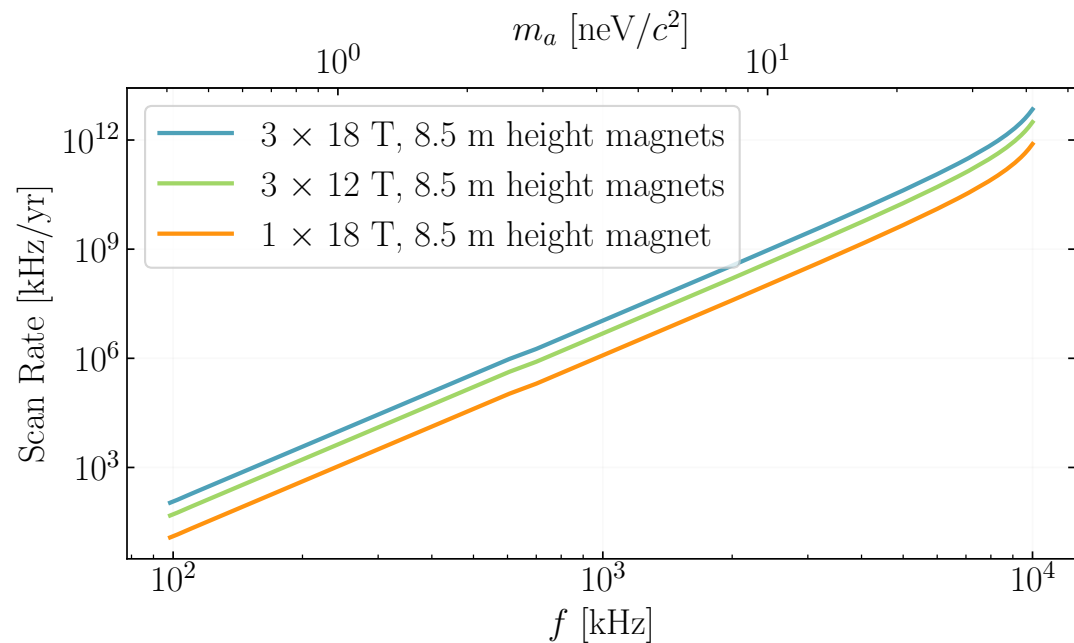

# Recap

# Recap: DMRadio-50L

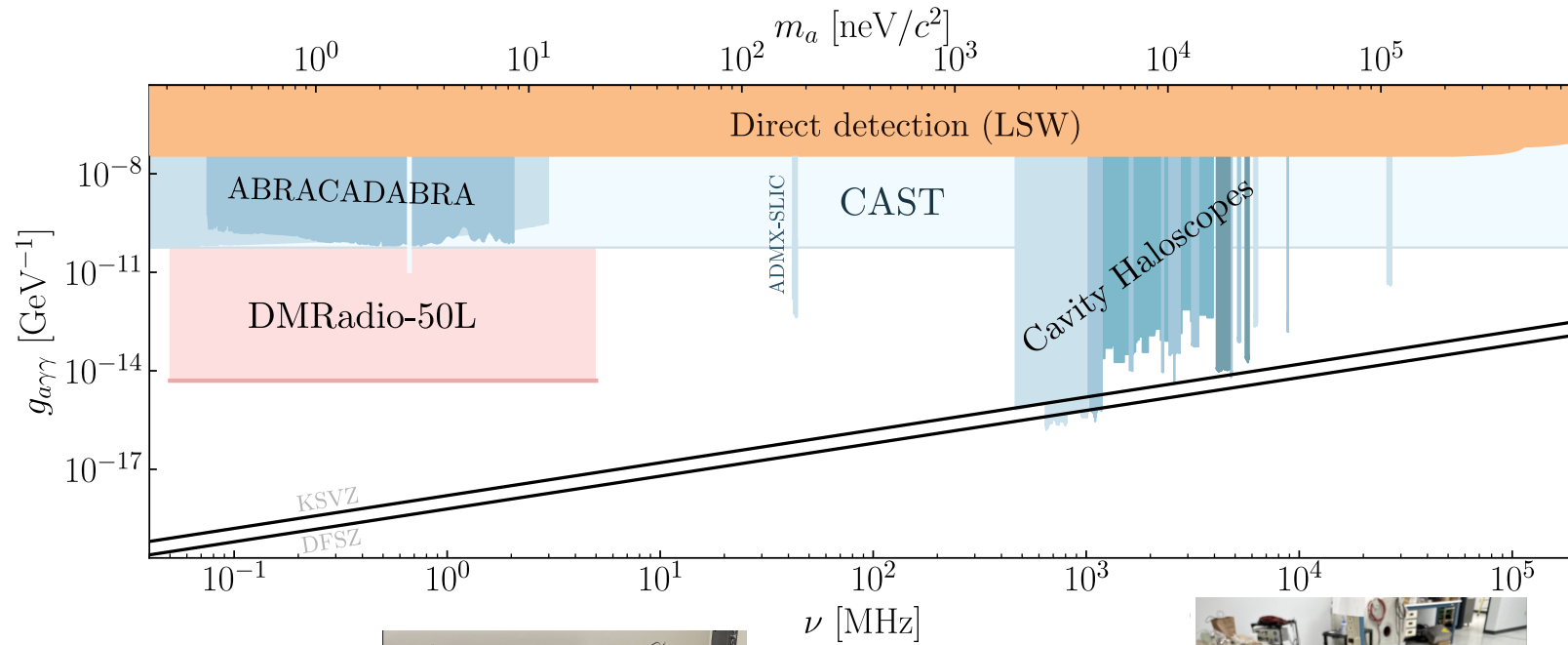

Ongoing commissioning at Stanford.  
Poised to take data soon

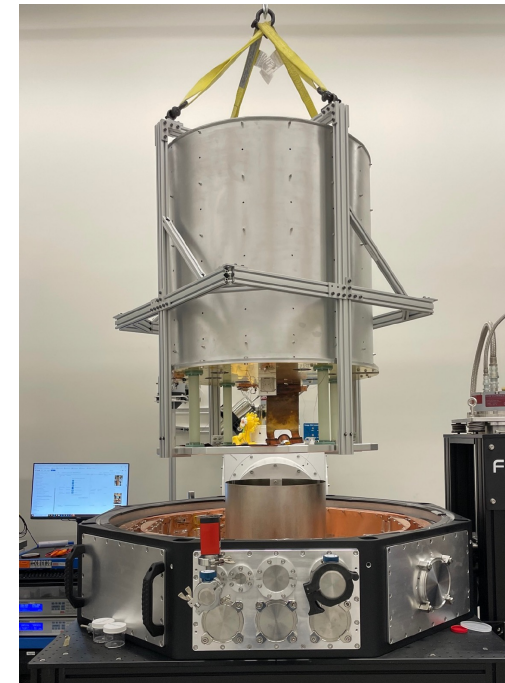
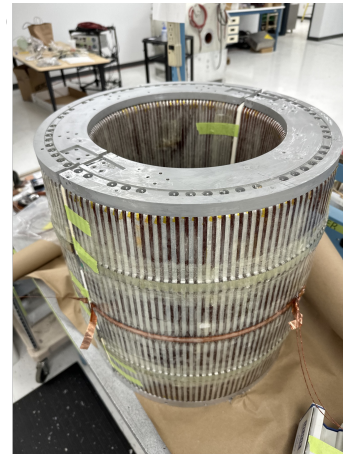
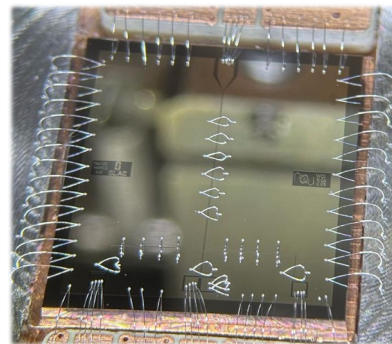
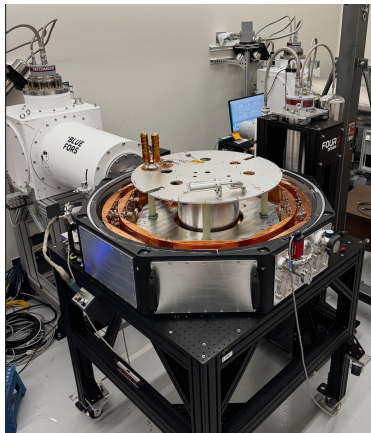

# Recap: the DMRadio program

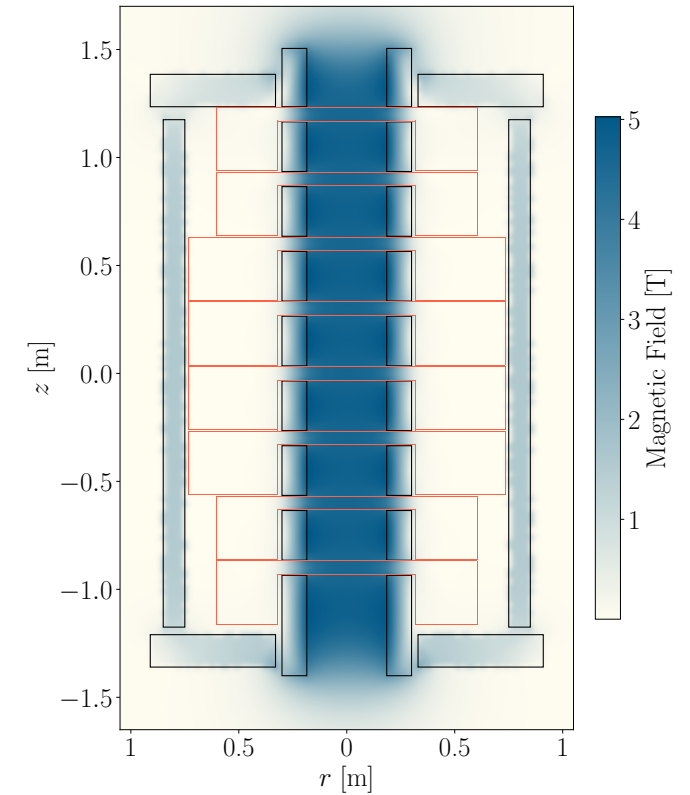
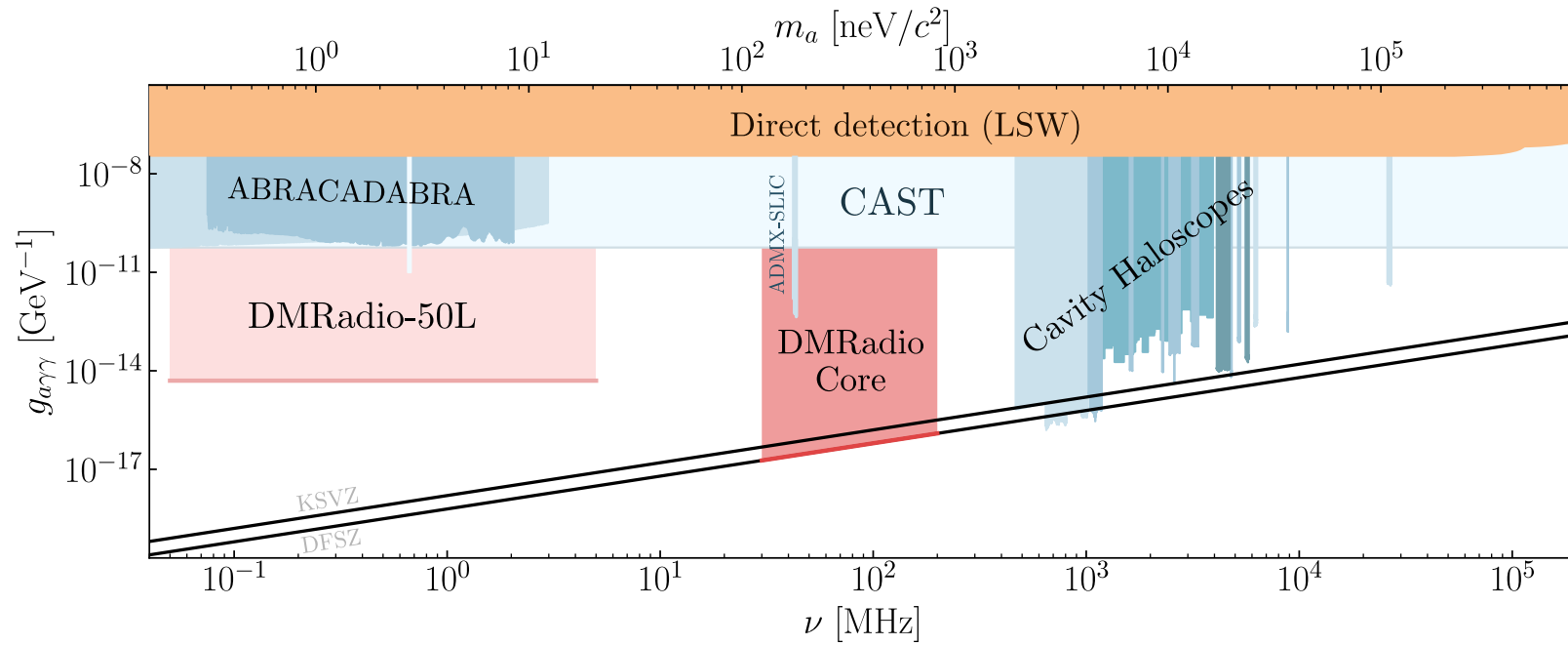

Much more efficient coupling to axion signal

New Core geometry reduces magnet energy to 10% of previous solenoidal designs

# Recap: the DMRadio program

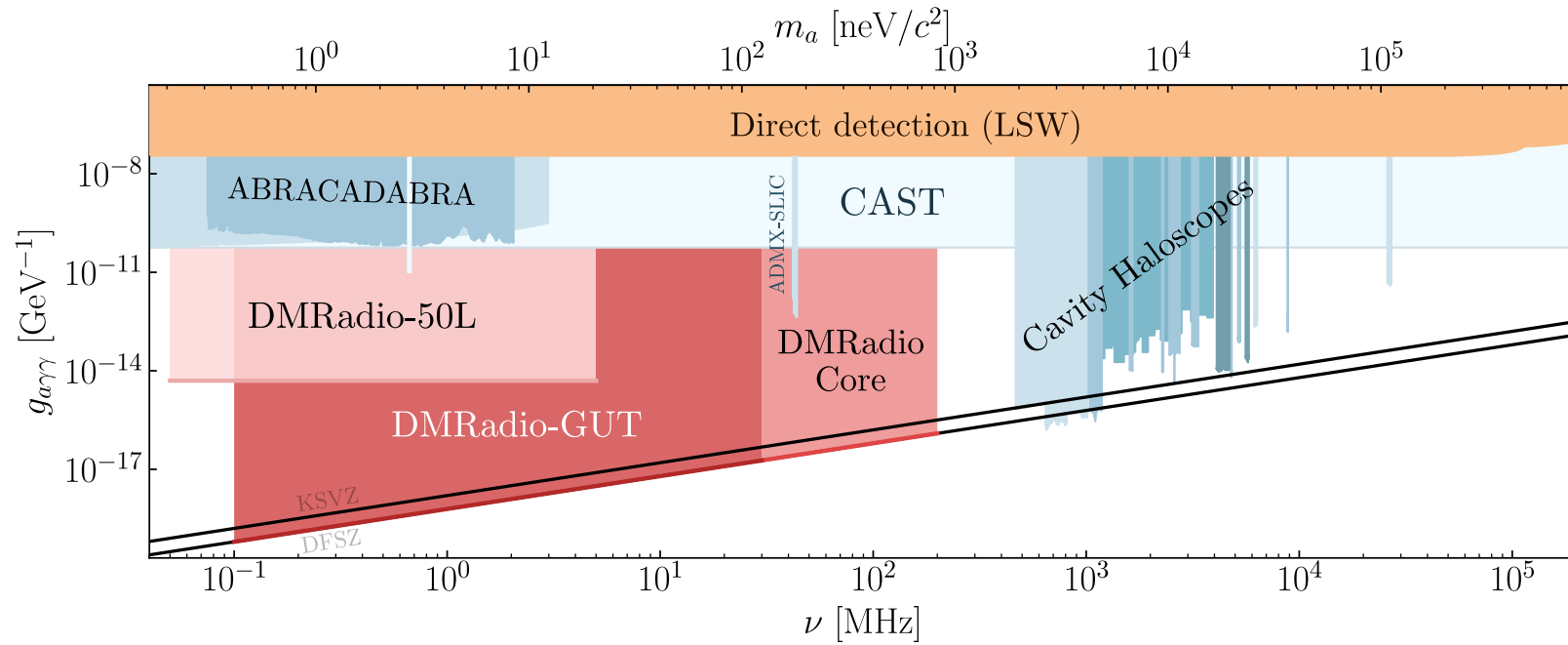

First design of experiment that can achieve sensitivity to neV axions at DFSZ

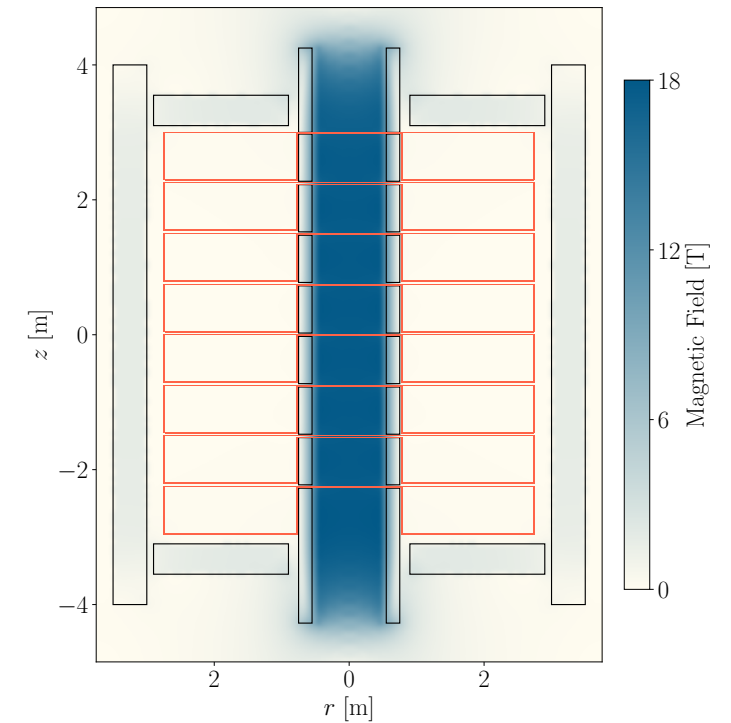

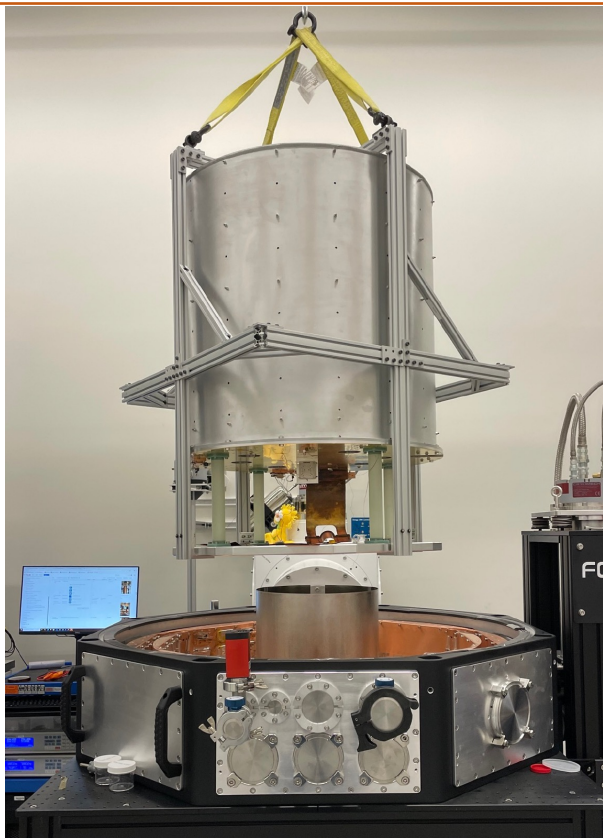

Thank you!

