

Agenda:

1. Linus & Nathan - Update on calculations for PRD paper 15'
2. German Luzin -Magnetic simulations from LU (missing slides) 15'
3. Mubi - Update from UKY 10'
4. Yuri – Goal of the magnet field uniformity 5'
5. Charlie - Update on GEANT calculations for fast n 10'
6. AOB 5'

Simulation of $n \rightarrow n'$ probabilities for PRD paper

2026-04-07

linus.persson@fysik.lu.se



Completed simulations

- Fixed typo in optical potential of cadmium, $V = 59.3e-8$ eV $\rightarrow V = 5.93e-8$ eV
- Ran 24 simulations with step size 30 μm , 2000 velocities, "single" precision:
 1. Two Δm ranges, 10-1000 neV ("large", linear), 0.01-20 neV ("small", log).
 2. Positive and negative Δm .
 3. Positive and negative polarisations.
 4. Three magnetic field strengths (2.4 T, 3.6 T, 4.8 T).
- Naming scheme:
B{field}_pol{p/n}_dm{neg/pos}_{large/small}.h5, e.g.
B24_poln_dmneg_large.h5
- All results files uploaded to:
OneDrive/DATA-GP-SANS-2025/PRD paper transition probabilities

Butterfly plots

- Polarisation are averaged to produce 12 figures. These are shown on the next slides.
- All figures currently have a threshold of 2.5×10^{-11} , I guess we should use the limits from Table I?

B-Field (T)	Counts, h^{-1}	Signal ($\times 10^{-12}$)	95% CL
2.40	-9 ± 21	-6.34 ± 14.7	2.28×10^{-11}
3.60	13 ± 20	9.1 ± 14.0	3.65×10^{-11}
4.80	-3 ± 20	-2.1 ± 14.0	2.55×10^{-11}
All fields	0.63 ± 12	0.42 ± 8.4	1.69×10^{-11}

TABLE I. Limits on the $n \rightarrow n' \rightarrow n$ regeneration probability per neutron at 95% CL [22] with Cd absorber for different values of magnetic field settings. Data of 2024 run.

2.4 T, Large Δm range

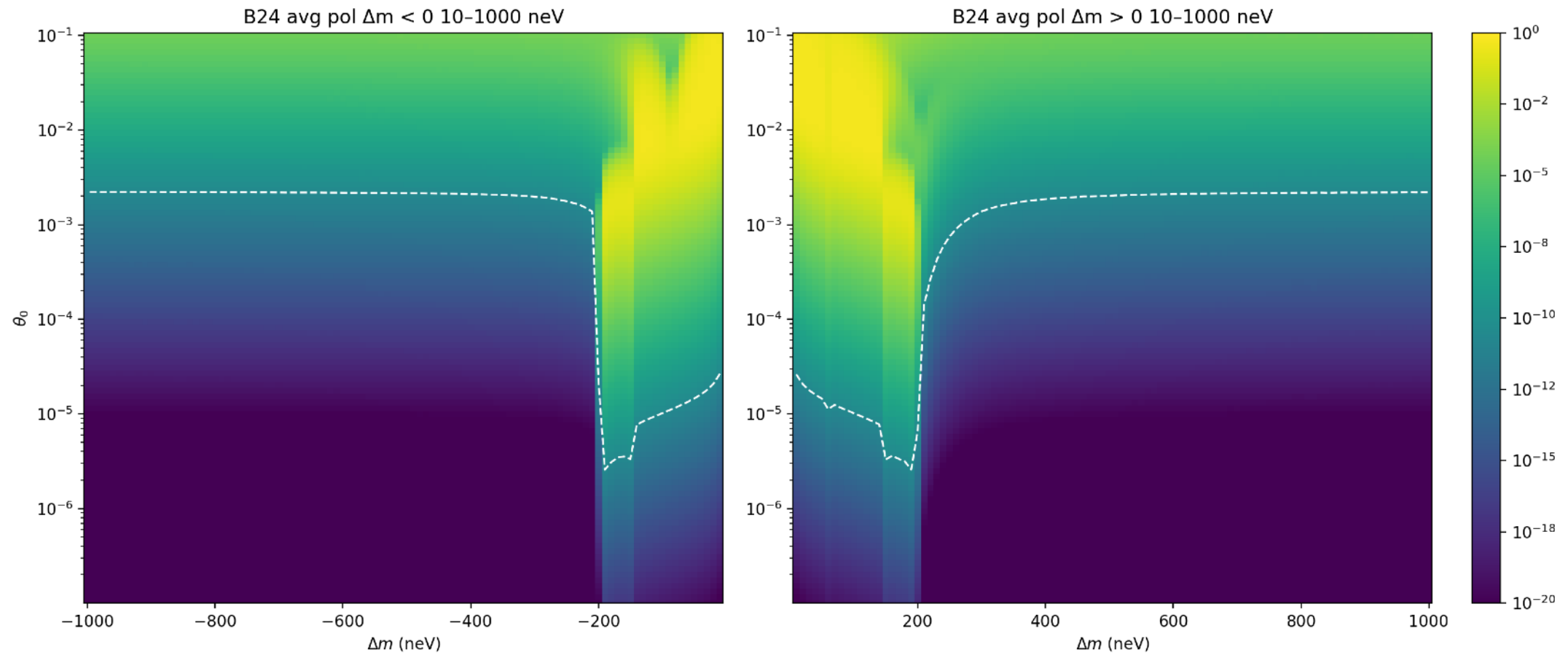

3.6 T, Large Δm range

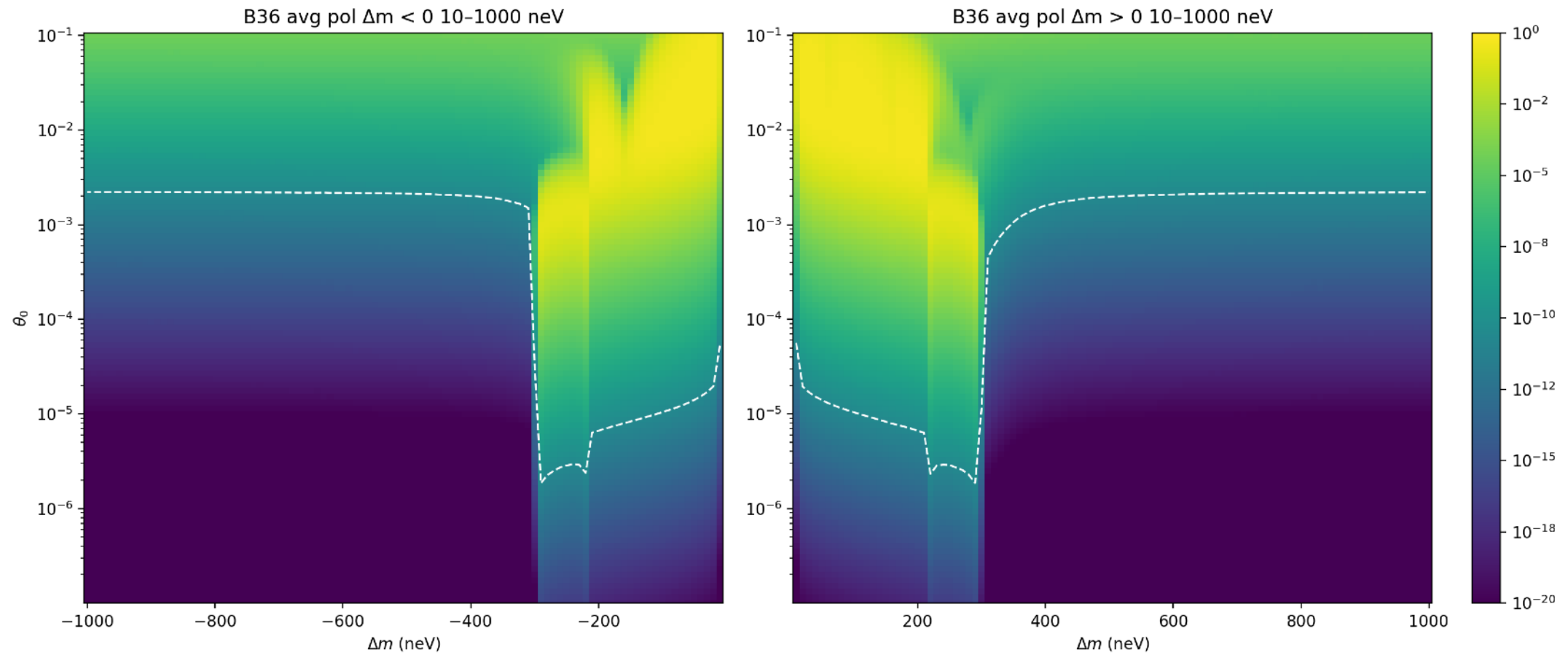

4.8 T, Large Δm range

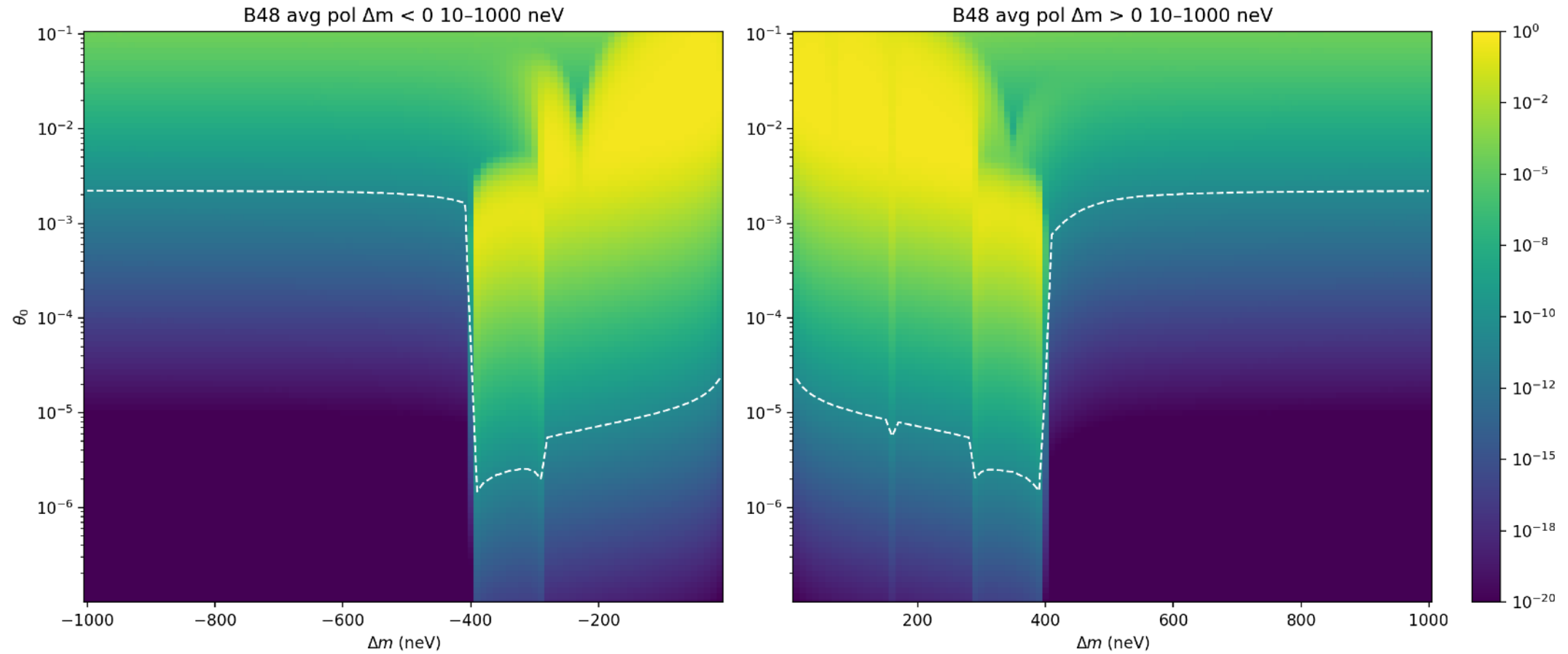

2.4 T, Small Δm range

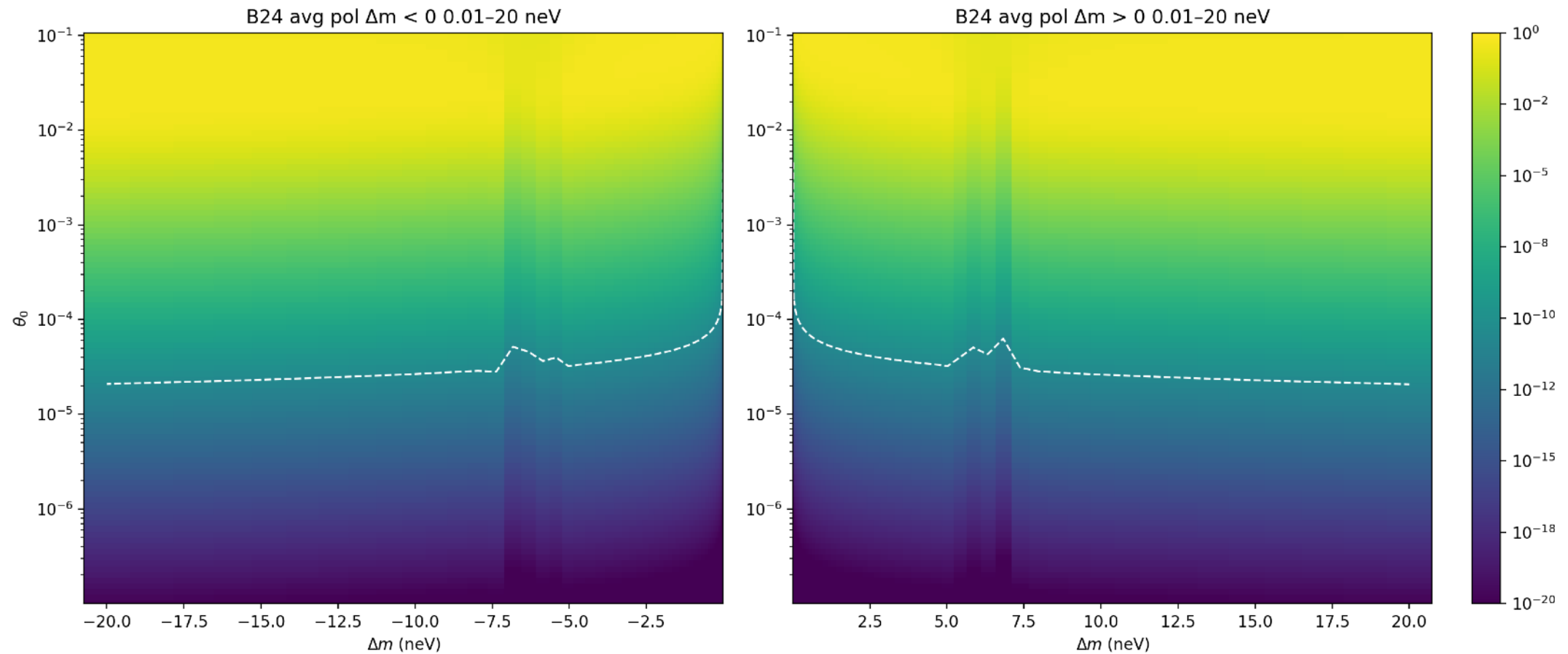

3.6 T, Small Δm range

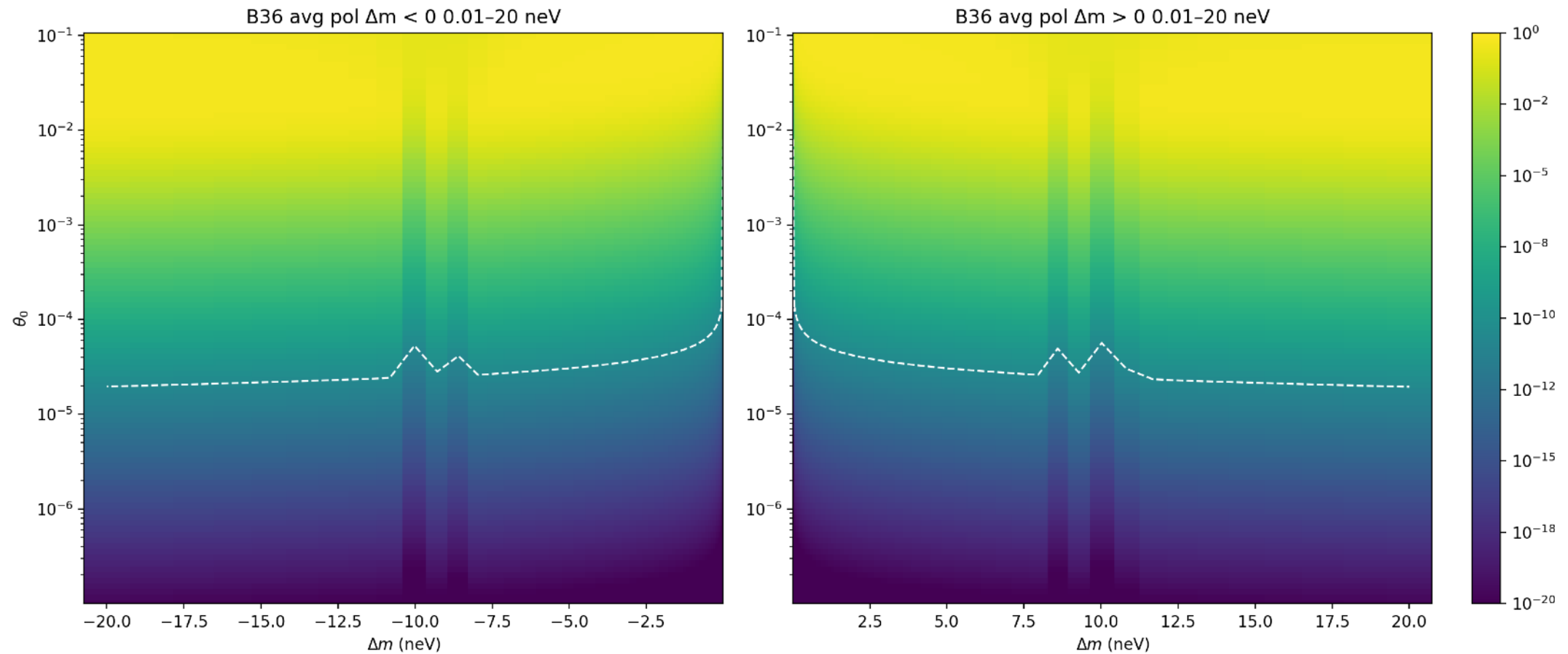

4.8 T, Small Δm range

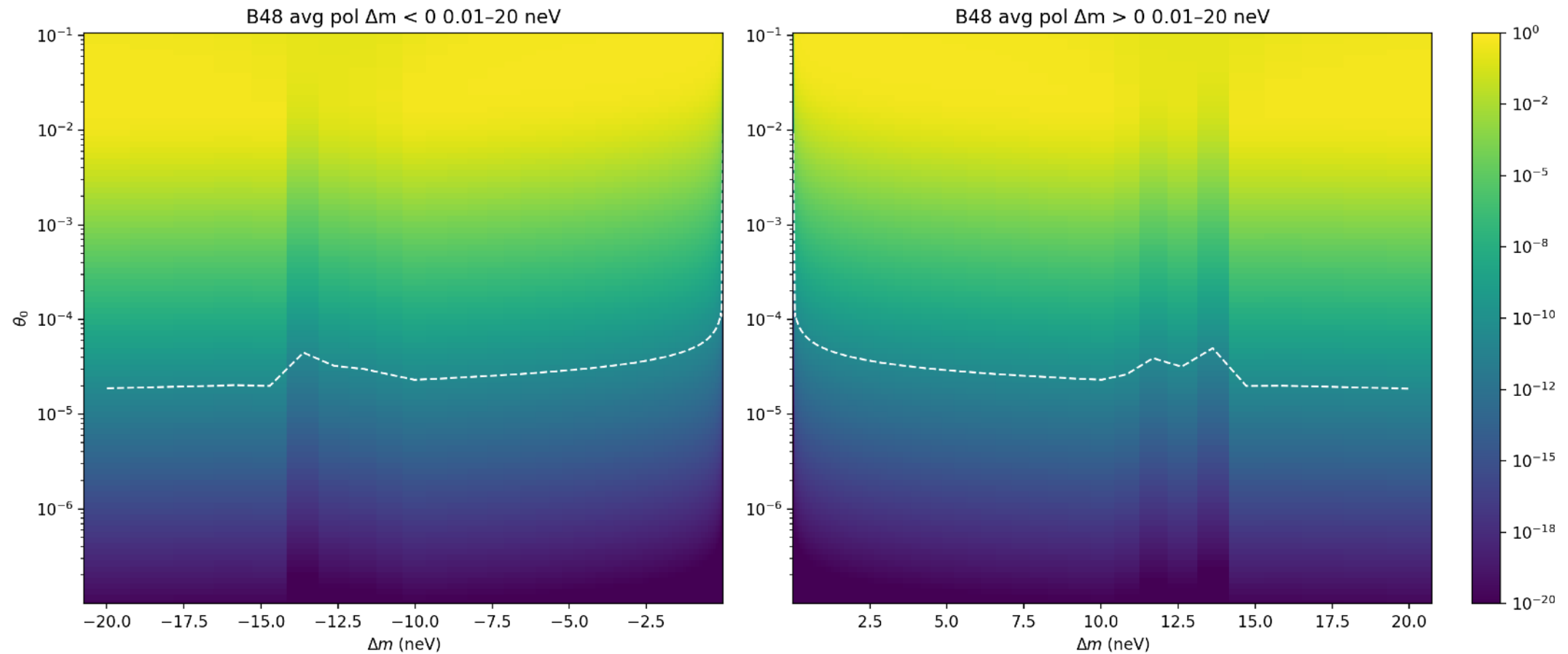

Next steps and discussion

- My understanding is that for each Δm , we take the smallest θ_0 between the three magnetic field configurations to obtain the final exclusion curve? The resulting curve plots $2\theta_0^2$ vs Δm .
- Is it enough to mention the cross-check between density matrix and Schrödinger equation calculations or should we add a figure?
- What should I and what should Nathan do?

Mubi Khan

University of Kentucky

April 7

New Approach

1. The major cause of magnetization in the steel leg is a 11 T Oxford Instruments America Superconducting Magnet. The stray field and picture of the magnet is shown below.

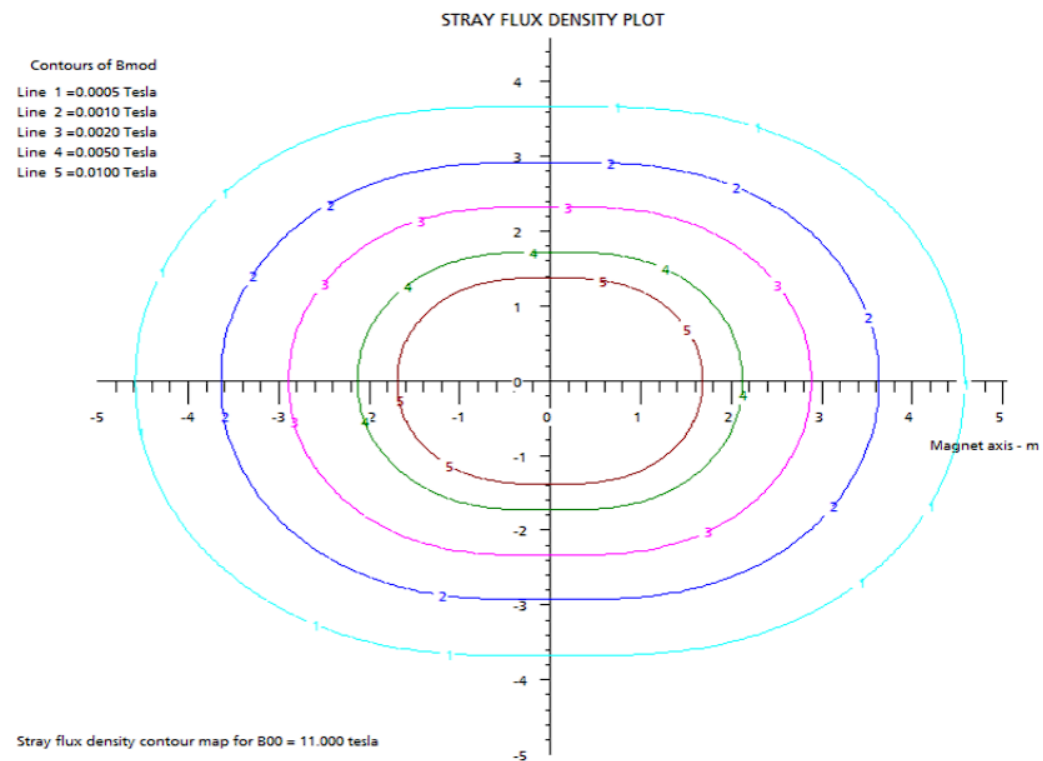

MAGNET FOR WINDOWS 2014

2. Using the stray field plot a model of the magnet is made in COMSOL. The COMSOL model is a three-coil magnet with appropriate currents tuned to match the stray field shown in the last slide.

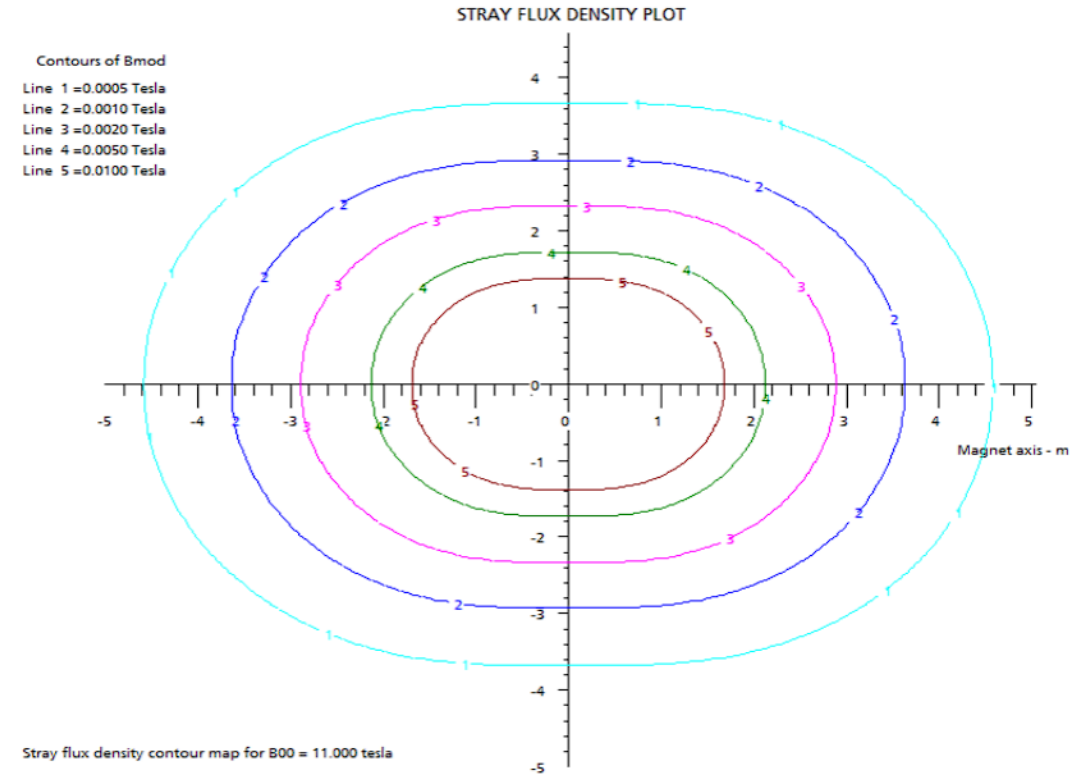
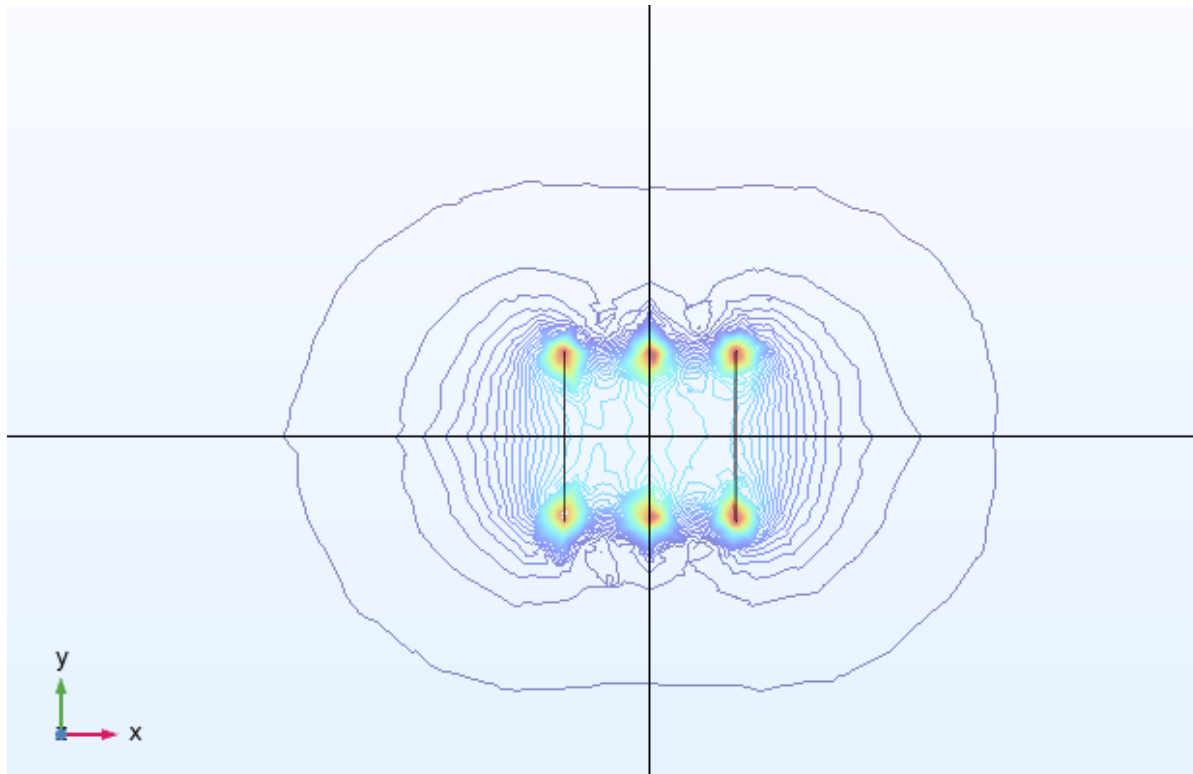

MAGNET FOR WINDOWS 2014

3. A COMSOL model is made (pictured below) in which the steel leg is assigned a $\mu_r = 1000$ to analyze the pattern of the magnetic flux entering the steel support which could tell us the magnetization vector in the steel leg
4. Once this is done, I will change the magnetization so that it matches the data from Evan (UTK)
5. Then, we can run the COMSOL model to see the uniformity in the magnet, and to see if the uniformity is lower than the scanning step ($4E-6$ T)

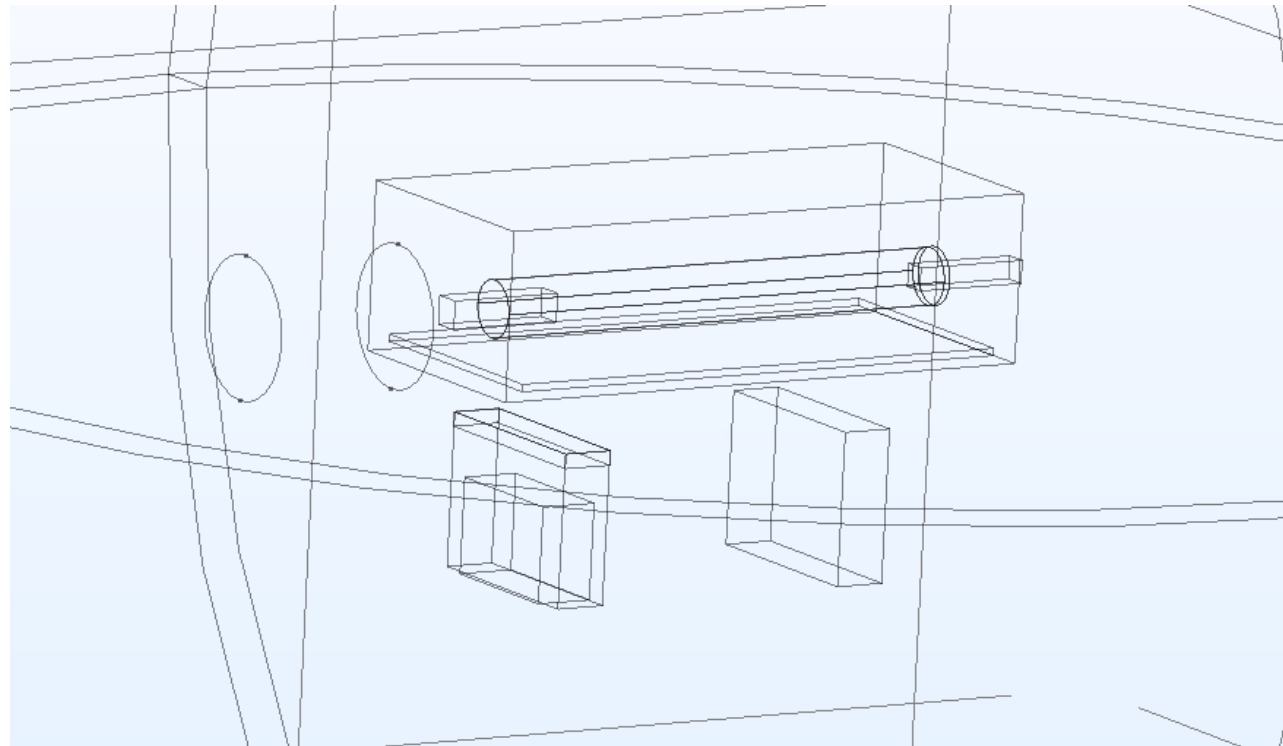

Goal of the magnet field uniformity

Yuri Kamyshev

n TMM experiment at GP-SANS/HFIR

Simulated expected resonance

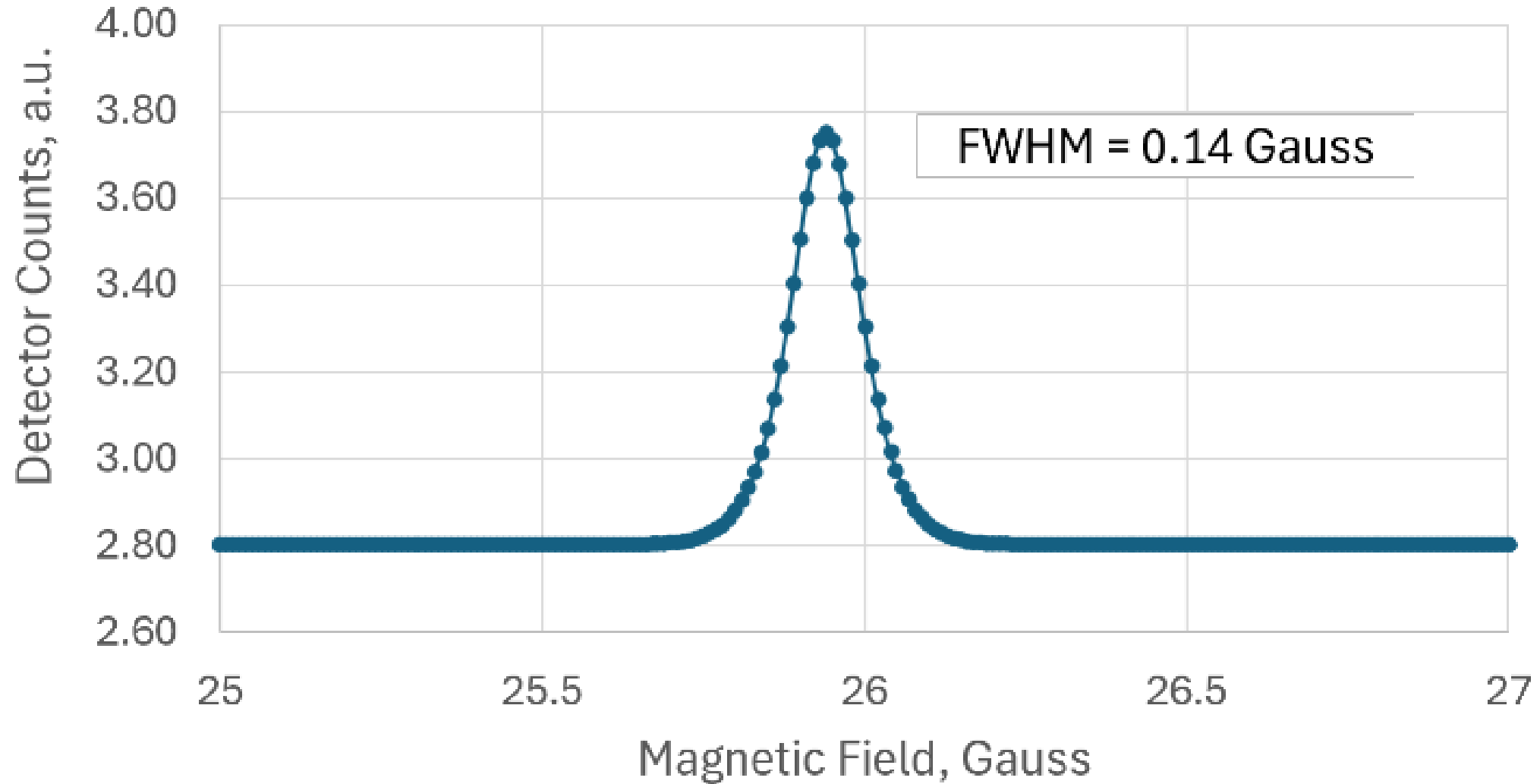

- Width of the expected resonance is 140 mG
 - Step in mag. field scan was 40 mG
 - Goal of magnet field uniformity is 20 mG over the effective length
 - Expected max perturbation on magnet axis 6000 mG
 - Desired shielding factor $SF=6000/20=300$
 - Non-uniformity should be mapped in calculation
-

- for UT prototype with single μ 0.3 mm $SF=65 \pm 15$ (Evan)
(perturbation 5 G, solenoidal field 10 G, with degaussing))
- for two shield layers (0.3 +0.3) $SF=145 \pm 45$ (Evan)
- for double μ 0.6 mm expected $SF = 130$
- expected for experiment configuration (0.6+0.3) $SF = 290$
- there is an option to double second shield to 0.6 mm (need \$5.5K)

Neutron Absorption Simulations Update

By Charlotte Snow

University of Denver

April 7, 2026

Successfully Uploaded Kyle's GPSANS Spectrum

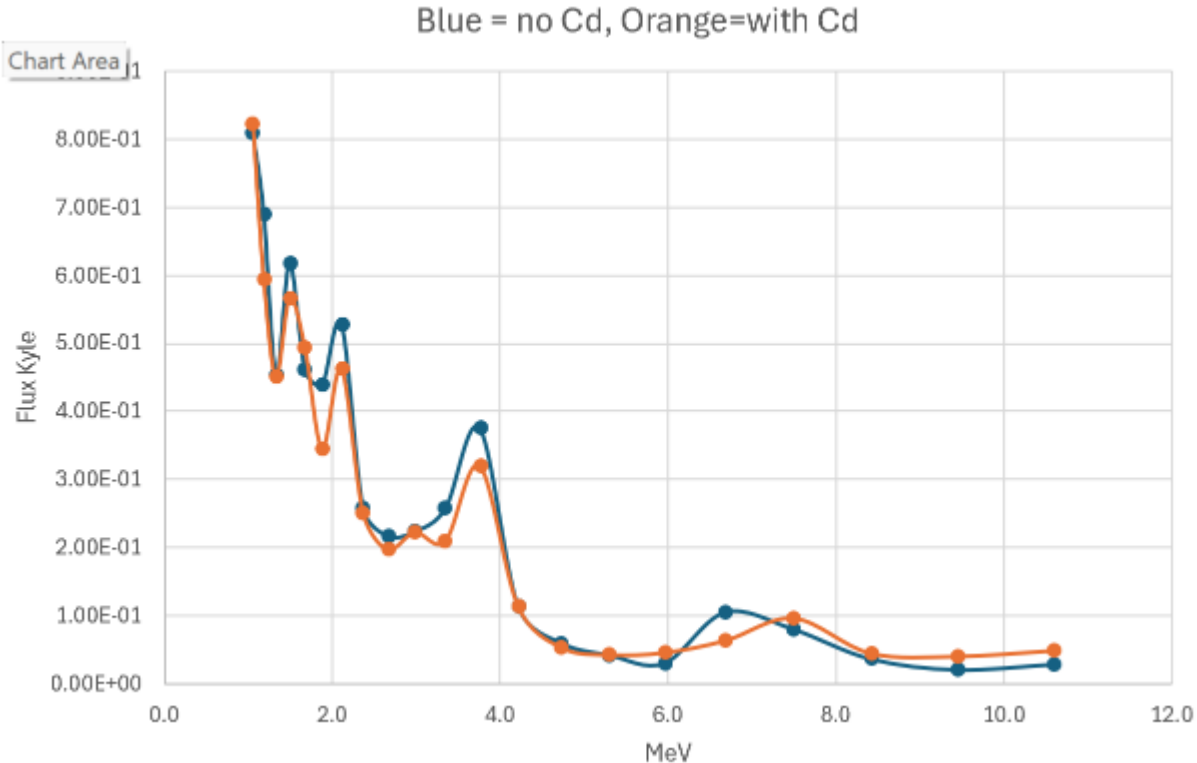

- Using MCNP Calculations made by Kyle, the Geant4 simulation now runs with the same “no Cd” spectrum
- Now we can compare calculations between MCNP and Geant4 to get a better idea of neutron transmission counts

Cadmium (3.5 mm) Comparisons

With Cd C vs K

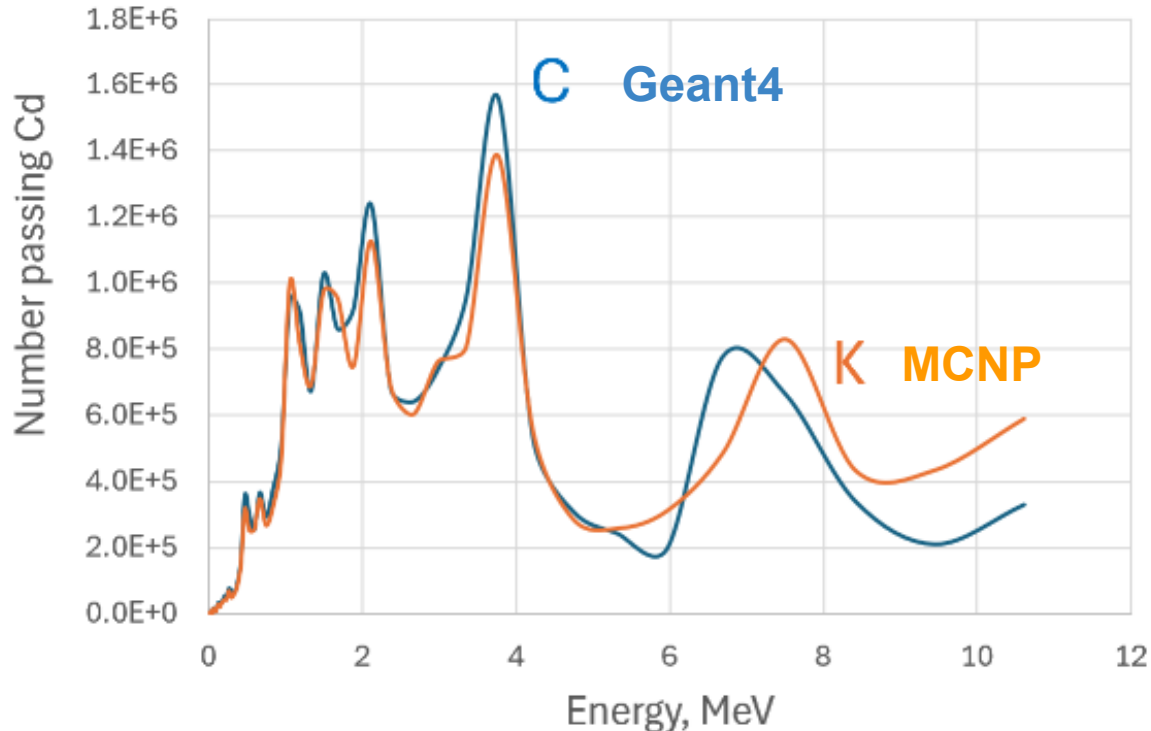

- Both simulations run with **1.87E+07** neutrons
- MCNP total transmitted neutron count: **1.78E+07**
- Geant4 total transmitted neutron count: **1.82E+07**
- Count difference may be due to statistical differences in simulation methods

Cadmium (3.5 mm) + Boron Nitride (6.35 mm) Comparisons

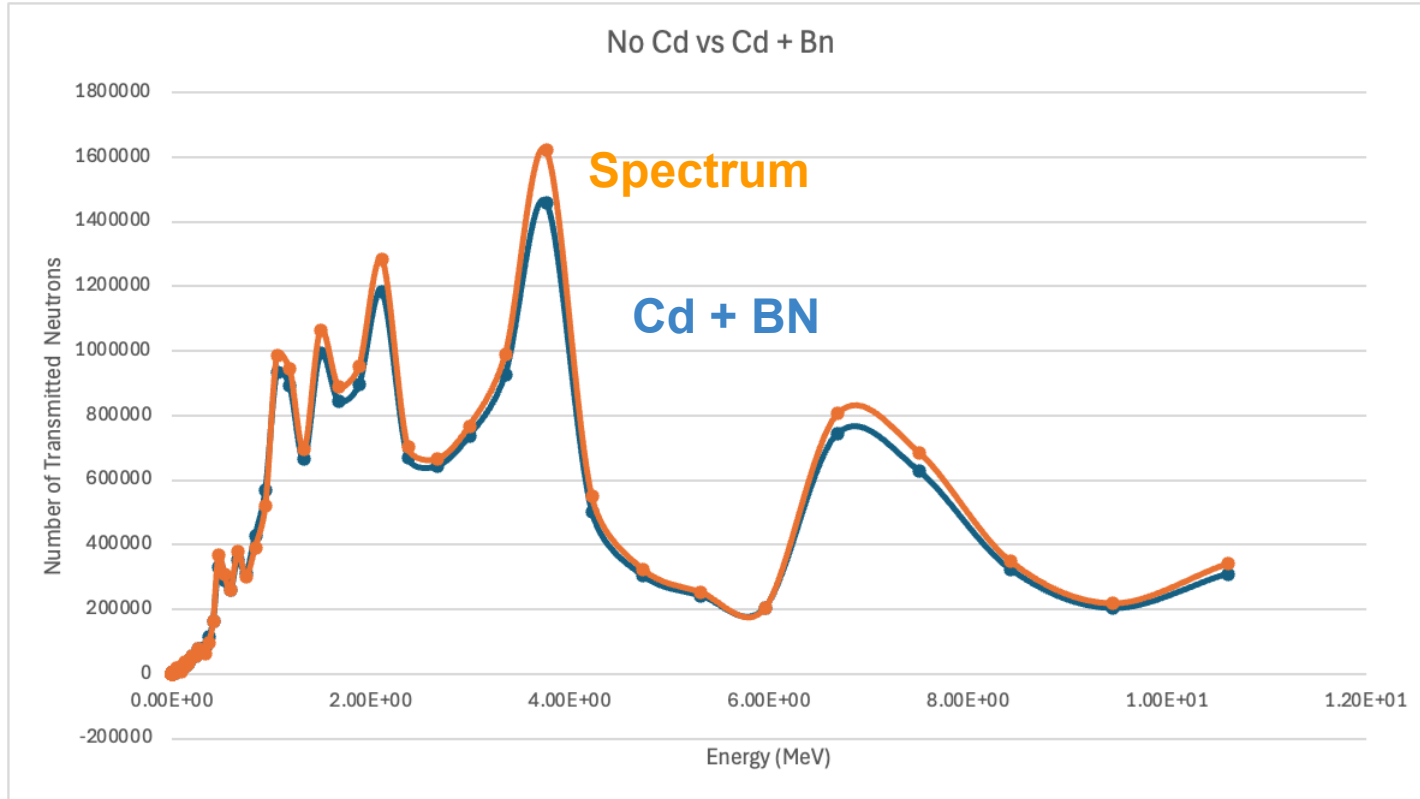

- Simulations run with **1.87E+07** neutrons
- Cd + BN total transmitted neutron count: **1.78E+07**
- Possible double counting - need to check

Next Steps

Simulate:

1. Shutter + Cd
2. Two shutters + Cd